



Externally bonded FRP reinforcement for RC structures

Externally bonded FRP reinforcement for RC structures

Technical report on the

**Design and use of externally bonded fibre reinforced polymer
reinforcement (FRP EBR) for reinforced concrete structures**

prepared by a working party of the

Task Group 9.3 *FRP (Fibre Reinforced Polymer) reinforcement for
concrete structures*

July 2001

Subject to priorities defined by the Steering Committee and the Praesidium, the results of <i>fib</i> 's work in Commissions and Task Groups are published in a continuously numbered series of technical publications called 'Bulletins'. The following categories are used:	
category	minimum approval procedure required prior to publication
Technical Report	approved by a Task Group and the Chairpersons of the Commission
State-of-Art report	approved by a Commission
Manual or Guide (to good practice)	approved by the Steering Committee of <i>fib</i> or its Publication Board
Recommendation	approved by the Council of <i>fib</i>
Model Code	approved by the General Assembly of <i>fib</i>
Any publication not having met the above requirements will be clearly identified as preliminary draft.	
This Bulletin N° 14 has been approved as a <i>fib</i> Technical Report in spring 2001 by <i>fib</i> Task Group 9.3 <i>FRP (Fibre Reinforced Polymer) reinforcement for concrete structures</i> and the Chairman of Commission 9.	

The report was drafted by the Working Party Externally Bonded Reinforcement (EBR) of *fib* Task Group 9.3 *FRP (Fibre Reinforced Polymer) reinforcement for concrete structures*:

Thanasis Triantafillou^{1,2,4,5,9-3,6,7} (Convenor, Greece), Stijn Matthys^{3,4,6,8-2,9} (Secretary, Belgium), Katrien Audenaert⁶ (Belgium), György Balázs⁷ (Hungary), Michael Blaschko^{4,9-2,3,8} (Germany), Hendrik Blontrock⁹⁻³ (Belgium), Christoph Czaderski^{3,5,7} (Switzerland), Emmanuelle David^{7,9-4} (France), Angello Di Tomasso⁸ (Italy), William Duckett⁸ (UK), Dick Hordijk² (The Netherlands), Michael Leeming^{4-8,9} (UK), Heinz Meier^{2,8} (Switzerland), Giorgio Monti⁶⁻⁴ (Italy), Richard Moss⁶ (UK), Uwe Neubauer⁴ (Germany), Roland Niedermeier⁴ (Germany), Bjørn Taljsten^{4,5-2,3,8} (Sweden), Gerhart Zehetmaier⁴ (Germany), Konrad Zilch⁸ (Germany)

^{1,2,3} ... Chapter number for which this member was the main preparing author

^{1,2,3} ... Chapter numbers for which this member provided contributions

Full affiliation details of all Task Groups members may be found in the *fib* Directory.

Cover picture: Applications of FRP EBR in RC structures

© fédération internationale du béton (*fib*), 2001

© for this non-print pdf-file version on CDs : fédération internationale du béton (*fib*), 2002

Although the International Federation for Structural Concrete *fib* - fédération internationale du béton - created from CEB and FIP, does its best to ensure that any information given is accurate, no liability or responsibility of any kind (including liability for negligence) is accepted in this respect by the organisation, its members, servants or agents.

All rights reserved. No part of this publication may be reproduced, modified, translated, stored in a retrieval system, or transmitted in any form or by any means, electronic, mechanical, photocopying, recording, or otherwise, without prior written permission.

First published 2001 by the International Federation for Structural Concrete (*fib*) as Bulletin 14

Post address: Case Postale 88, CH-1015 Lausanne, Switzerland

Street address: Federal Institute of Technology Lausanne - EPFL, Département Génie Civil

Tel (+41.21) 693 2747, Fax (+41.21) 693 5884, E-mail fib@epfl.ch, web http://fib.epfl.ch

ISSN 1562-3610

ISBN 2-88394-054-1

Printed by Sprint-Digital-Druck Stuttgart

Preface

In December 1996, the then CEB established a Task Group with the main objective to elaborate design guidelines for the use of FRP reinforcement in accordance with the design format of the CEB-FIP Model Code and Eurocode2. With the merger of CEB and FIP into *fib* in June 1998, this Task Group became *fib* TG 9.3 *FRP Reinforcement for concrete structures* in Commission 9 *Reinforcing and Prestressing Materials and Systems*. The Task Group consists of about 60 members, representing most European universities, research institutes and industrial companies working in the field of advanced composite reinforcement for concrete structures, as well as corresponding members from Canada, Japan and USA. Meetings are held twice a year and on the research level its work is supported by the EU TMR (European Union Training and Mobility of Researchers) Network “ConFibreCrete”.

The work by *fib* TG 9.3 is performed by five working parties (WP):

1. Material Testing and Characterization (MT&C) Convenors: C. Burgoyne, A. Gerritse
2. Reinforced Concrete (RC) Convenors: A. Hole, K. Pilakoutas
3. Prestressed Concrete (PC) Convenor: L. Taerwe
4. Externally Bonded Reinforcement (EBR) Convenor: T. Triantafillou
5. Marketing and Applications (M&A) Convenors: G. Pascale, A. Di Tommaso

This technical report constitutes the work conducted as of to date by the EBR party.

Membership in this sub-group has been increasing constantly over the past few years and today reaches a number in the order of 30. The working party met typically twice a year for one and a half day meetings. Furthermore, the internet provided an excellent communication platform. An important step forward was the setting up of a home page, thanks to the efforts of Stijn Matthys at Ghent University.

This bulletin gives detailed design guidelines on the use of FRP EBR, the practical execution and the quality control, based on the current expertise and state-of-the-art knowledge of the task group members. The bulletin is regarded as a progress report since

- It is not the aim of this report to cover all aspects of RC strengthening with composites. Instead, it focuses on those aspects that form the majority of the design problems.
- Several of the topics presented are subject of ongoing research and development, and the details of some modelling approaches may be subjected to future revisions.
- As knowledge in this field is advancing rapidly, the work of the EBR WP will continue.

In spite of this limit in scope, considerable effort has been made to present a bulletin that is today's state-of-art in the area of strengthening of concrete structures by means of externally bonded FRP reinforcement.

All persons having participated in the preparation of this report are mentioned in the copyright page. Further acknowledgements are due to Urs Meier (Switzerland) and Ferdinand Rostasy (Germany) for revision of the document, and to Richard Moss (UK) for linguistic assistance. To all members of the EBR WP my sincere thanks are expressed for the high-quality and extensive work brought in on a voluntary basis.

Patras, March 2001

Thanasis TRIANTAFILLOU
Convenor of WP EBR

Contents

1 INTRODUCTION

- 1.1 Repair, strengthening, retrofit
- 1.2 Externally bonded FRP reinforcement (EBR)
- 1.3 Applications of EBR
- 1.4 Content and aim of this report

2 FRP STRENGTHENING MATERIALS AND TECHNIQUES

- 2.1 Materials for FRP strengthening
- 2.2 FRP EBR systems
- 2.3 Techniques for FRP strengthening

3 BASIS OF DESIGN AND SAFETY CONCEPT

- 3.1 Basis of design
- 3.2 Safety concept
- 3.3 Ductility

4 FLEXURAL STRENGTHENING

- 4.1 General
- 4.2 Initial situation
- 4.3 Failure modes – ultimate limit states
- 4.4 Analysis of ULS
- 4.5 Ductility requirements
- 4.6 Serviceability limit state
- 4.7 Summary of design procedure
- 4.8 Special cases

Appendix Chapter 4:

ULS verification of peeling-off at the end anchorage and at flexural cracks

- 4-A.1 Anchorage verification and FRP strain limitation
- 4-A.2 Calculation of the envelope line of tensile stresses
- 4-A.3 Verification of anchorage and of force transfer between frp and concrete

5 STRENGTHENING IN SHEAR AND TORSION

- 5.1 Strengthening in shear
- 5.2 Strengthening in torsion

6 CONFINEMENT

- 6.1 Introduction
- 6.2 Concrete confined by external FRP reinforcement under axial loading
- 6.3 Confinement of columns
- 6.4 Confinement in seismic regions for ductility increase
- 6.5 FRP as formwork and structural reinforcement

7 DETAILING RULES

- 7.1 General
- 7.2 Detailing with respect to strengthening lay-out
- 7.3 Special anchorages

8 PRACTICAL EXECUTION AND QUALITY CONTROL

- 8.1 Techniques
- 8.2 General requirements
- 8.3 Practical execution
- 8.4 Quality control

9 SPECIAL DESIGN CONSIDERATIONS AND ENVIRONMENTAL EFFECTS

- 9.1 General
- 9.2 Glass transition temperature
- 9.3 Fire design and protection
- 9.4 Moisture
- 9.5 Freeze-thaw
- 9.6 UV light exposure
- 9.7 Alcalinity/acidity
- 9.8 Creep, stress rupture and stress corrosion
- 9.9 Fatigue
- 9.10 Impact
- 9.11 Lightning, galvanic corrosion

References

Symbols

Glossary

Adherent – A body held to another body by an adhesive.

Adhesive – Substance applied to mating surfaces to bond them together by bonding. An adhesive can be in liquid, film or paste form.

AFRP – Aramid Fibre Reinforced Polymer.

AR-Glass – Stands for “alkali-resistant glass” and refers to zirconia glass.

Aramid – High-strength, high-stiffness aromatic polyamide fibres.

Bi-directional – A strip or fabric with fibres oriented in two directions in the same plane.

Binder – A component of an adhesive that is primarily responsible for the adhesive forces that hold two bodies together.

Bond – See adhesive.

Buckling – A failure mode usually characterised by fibre deflection rather than breaking because of compressive action.

Carbon Fibre – Fibre produced by high temperature treatment of an organic precursor fibre based on PAN (polyacrylonitrile) rayon or pitch in an inert atmosphere at temperatures above 980°C. Fibres can be graphitised by removing still more of the non-carbon atoms by heat treating above 1650°C.

CFRP - Carbon Fibre Reinforced Polymer.

Cure – To change the molecular structure and physical properties of a thermosetting resin by chemical reaction via heat and catalysts or in combination, with or without pressure.

Debonding – Local failure in the bond zone between concrete and the externally bonded reinforcement.

Delamination – Separation of layers in a laminate because of the failure of the adhesive, either in the adhesive itself or at the interface between the adhesive and the adherent.

E-Glass – Stands for “electrical glass” and refers to alumino-borosilicate glass most often used in conventional polymer matrix composites.

Epoxide – Compound containing a three-member ring consisting of two carbon atoms and one oxygen atom.

Epoxy Resin – A polymer resin characterised by epoxide molecule groups.

Fabric, Non-woven – A material formed from fibres or yarns without interlacing.

Fabric, Woven – A material constructed of interlaced yarns, fibres or filaments.

Fibre – A general term used to refer to filamentary materials. Fibre is often used synonymously with filament.

Filaments – Individual fibres of indefinite length used in tows, yarns or rovings.

Filler – A relatively non-adhesive substance added to an adhesive to improve its working properties, permanence, strength or other qualities.

FRP - Fibre Reinforced Polymer.

GFRP - Glass Fibre Reinforced Polymer.

Glass Fibre – Reinforcing fibre made by drawing molten glass through brushings. The predominant reinforcement for polymer matrix composites. Known for its good strength, processability and low cost.

Glass Transition Temperature (T_g) – Approximate temperature above which increased molecular mobility causes a material to become rubbery rather than brittle. The measured value of T_g can vary, depending on the test method.

Glue – See adhesive.

Hand Lay-up – A fabrication method in which reinforcement layers are placed in a mould or on a structure by hand, then cured to the formed shape.

Hardener – Substance that reacts with the resin to promote or control curing action by taking part in it. Also a substance added to control the degree of hardness of the resin.

Impregnate – To saturate the voids of a reinforcement with a resin manually or with a machine.

Interlaminar shear – shear force acting at the interface between adjacent layers (laminae) of a laminate.

Laminate – To unite layers of material with an adhesive. Also, a product made by bonding together two or more layers of materials.

Lay-up – Placement of layers of reinforcement in a mould.

Matrix – Binder material in which reinforcing fibre is embedded. Usually a polymer but may also be metal or a ceramic.

Open time – The time interval between the spreading of the adhesive on the adherent and the completion of the assembly of the parts for bonding.

PAN (polyacrylonitrile) – Used as a base material or precursor in the manufacture of certain carbon fibres.

Pitch – A high molecular weight material that is a residue from the destructive distillation of coal and petroleum products. Pitches are used as base materials for the manufacture of certain high-modulus carbon fibres.

Polyester – Unsaturated polyesters are manufactured by reacting glycols with either dibasic acids or anhydrides. Polyesters are normally cured at room temperature with a monomer such as styrene.

Polymer – Large molecule formed by combining many smaller molecules or monomers in a regular pattern.

Polymerisation – Chemical reaction that links monomers together to form polymers.

Post-cure – An additional elevated temperature exposure to improve mechanical properties.

Pot life – Length of time in which a catalysed thermosetting resin retains sufficiently low viscosity for processing.

Prepreg – Resin-impregnated fabric or filaments in flat form that can be stored at very low temperature for later use in moulds or hand lay-up. The resin is often partially cured to a tack-free state.

Primer – A coating applied to a surface prior to the application of an adhesive to improve the performance of the bond. The coating can be a low viscosity fluid that is typically a 10% solution of the adhesive in an organic solvent, which can wet out the adherent surface to leave a coating over which the adhesive can readily flow.

Pultrusion – An automated, continuous process for manufacturing composite rods and structural shapes having a constant cross section. Roving and/or tows are saturated with resin and continuously pulled through a heated die, where the part is formed and cured. The cured part is then cut to length. For some applications fabrics can be included into the profiles.

Putty – repair mortar.

Reinforcement – Key element added to matrix to provide the required properties. Ranges from short and continuous fibres through complex textile forms.

Resin – Polymer with indefinite and often high molecular weight and a softening or melting range that exhibits a tendency to flow when subjected to stress. As composite matrices, resins bind together reinforcement fibres.

Roving – A collection of bundles of continuous filaments either as untwisted strands or as twisted yarns.

Sheet – See fabric, non-woven.

Shelf Life – Length of time in which a material can be stored and continue to meet the specifications requirements, remaining suitable for its intended use.

Stress Corrosion – Corrosion due to the effect of a corrosive environment, which is activated in the presence of stress.

Stress Rupture – The reduction of tensile strength due to sustained loading.

Strip – Pre-manufactured forms made of fibres and resin. Strips are normally pultruded.

Thermoplastic – A composite matrix capable of being repeatedly softened by an increase of temperature and hardened by cooling.

Thermoset – Composite matrix cured by heat and pressure or with a catalyst into an infusible and insoluble material. Once cured a thermoset cannot be returned to the uncured state.

Thixotropy – A property of adhesive systems to thin upon isothermal agitation and to thicken upon subsequent rest. Thixotropic materials have a high static shear strength and low dynamic shear strength at the same time. They lose their viscosity under stress.

Tow – An untwisted bundle of continuous filaments, usually designated by a number followed by K, indicating multiplication by 1000. For example, 12 K tow has 12 000 filaments.

Unidirectional – A strip or fabric with all fibres oriented in the same direction.

Vinyl ester – A class of thermosetting resins containing esters of acrylic and/or methacrylic acids, many of which have been made from epoxy resin. Cure is accomplished, as with unsaturated polyesters, by co-polymerisation with other vinyl monomers, such as styrene.

Viscosity – Tendency of a material to resist flow. As temperature increases, the viscosity of most materials decreases.

Warp – Yarns running lengthwise and perpendicular to the narrow edge of woven fabric.

Weft – Yarns running perpendicular to the warp in a woven fabric.

Wet Lay-up – Fabrication step involving application of a resin to dry reinforcement.

Yarn – Continuously twisted fibres or strands that are suitable for weaving into fabrics.

1 Introduction

1.1 Repair, strengthening, retrofit

The issue of upgrading the existing civil engineering infrastructure has been one of great importance for over a decade. Deterioration of bridge decks, beams, girders and columns, buildings, parking structures and others may be attributed to ageing, environmentally induced degradation, poor initial design and/or construction, lack of maintenance, and to accidental events such as earthquakes. The infrastructure's increasing decay is frequently combined with the need for upgrading so that structures can meet more stringent design requirements (e.g. increased traffic volumes in bridges exceeding the initial design loads), and hence the aspect of civil engineering infrastructure renewal has received considerable attention over the past few years throughout the world. At the same time, seismic retrofit has become at least equally important, especially in areas of high seismic risk.

1.2 Externally bonded FRP reinforcement (EBR)

Recent developments related to materials, methods and techniques for structural strengthening have been enormous. One of today's state-of-the-art techniques is the use of fibre reinforced polymer (FRP) composites, which are currently viewed by structural engineers as "new" and highly promising materials in the construction industry. Composite materials for strengthening of civil engineering structures are available today mainly in the form of:

- thin unidirectional *strips* (with thickness in the order of 1 mm) made by pultrusion
- flexible *sheets* or *fabrics*, made of fibres in one or at least two different directions, respectively (and sometimes pre-impregnated with resin)

For comparison with steel, typical stress-strain diagrams for unidirectional composites under short-term monotonic loading are given in Fig. 1-1.

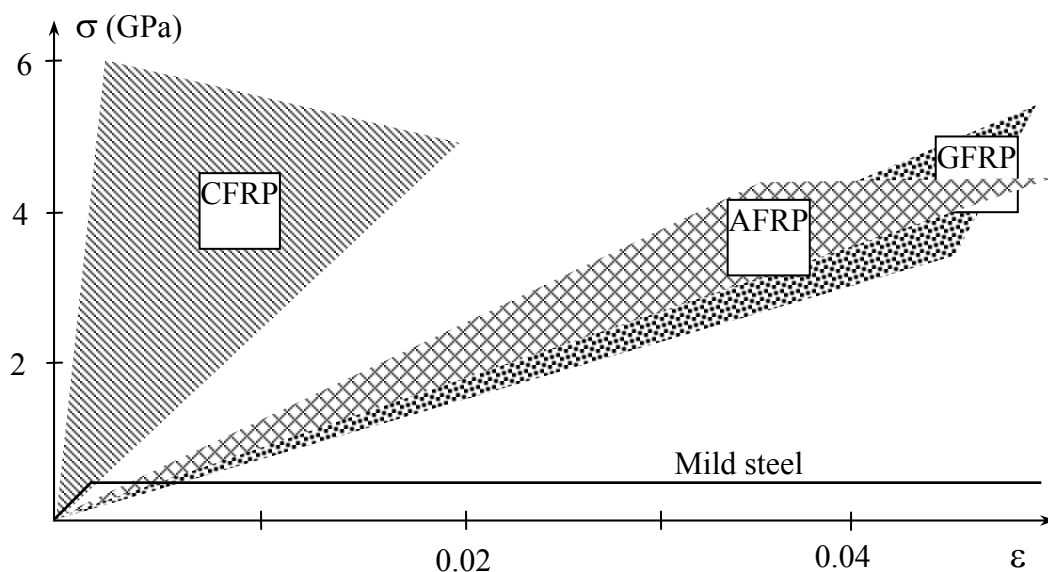

Fig. 1-1: Uniaxial tension stress-strain diagrams for different unidirectional FRPs and steel. CFRP = carbon FRP, AFRP = aramid FRP, GFRP = glass FRP.

The reasons why composites are increasingly used as strengthening materials of reinforced concrete elements may be summarised as follows: immunity to corrosion; low weight (about $\frac{1}{4}$ of steel), resulting in easier application in confined space, elimination of the need for scaffolding and reduction in labour costs; very high tensile strength (both static and long-term, for certain types of FRP materials); stiffness which may be tailored to the design requirements; large deformation capacity; and practically unlimited availability in FRP sizes and FRP geometry and dimensions. Composites suffer from certain disadvantages too, which are not to be neglected by engineers: contrary to steel, which behaves in an elastoplastic manner, composites in general are linear elastic to failure (although the latter occurs at large strains) without any significant yielding or plastic deformation, leading to reduced ductility. Additionally, the cost of materials on a weight basis is several times higher than that for steel (but when cost comparisons are made on a strength basis, they become less unfavourable). Moreover, some FRP materials, e.g. carbon and aramid, have incompatible thermal expansion coefficients with concrete. Finally, their exposure to high temperatures (e.g. in case of fire) may cause premature degradation and collapse (some epoxy resins start softening at about 45-70 °C). Hence FRP materials should not be thought of as a blind replacement of steel (or other materials) in structural intervention applications. Instead, the advantages offered by them should be evaluated against potential drawbacks, and final decisions regarding their use should be based on consideration of several factors, including not only mechanical performance aspects, but also constructibility and long-term durability.

1.3 Applications of EBR

Composites have found their way as strengthening materials of reinforced concrete (RC) elements (such as beams, slabs, columns etc.) in thousands of applications worldwide, where conventional strengthening techniques may be problematic. For instance, one of the popular techniques for upgrading RC elements has traditionally involved the use of steel plates epoxy-bonded to the external surfaces (e.g. tension zones) of beams and slabs. This technique is simple and effective as far as both cost and mechanical performance is concerned, but suffers from several disadvantages (Meier 1987): corrosion of the steel plates resulting in bond deterioration; difficulty in manipulating heavy steel plates in tight construction sites; need for scaffolding; and limitation in available plate lengths (which are required in case of flexural strengthening of long girders), resulting in the need for joints. Replacing the steel plates with FRP strips (Fig. 1-2 a, b) provides satisfactory solutions to the problems described above. Another common technique for the strengthening of RC structures involves the construction of reinforced concrete (either cast in-place or shotcrete) jackets (shells) around existing elements. Jacketing is clearly quite effective as far as strength, stiffness and ductility is concerned, but it is labour intensive, it often causes disruption of occupancy and it provides RC elements, in many cases, with undesirable weight and stiffness increase. Jackets may also be made of steel; but in this case protection from corrosion is a major issue. The conventional jackets may be replaced with FRP fabrics or sheets wrapped around RC elements (Fig. 1-2 c, d), thus providing substantial increase in strength (axial, flexural, shear, torsional) and ductility without much affecting the stiffness. The range of applicability of EBR in RC structures is increasing constantly: a typical example is the recently developed technique of shear strengthening in beam-column joints (Fig. 1-2 e).

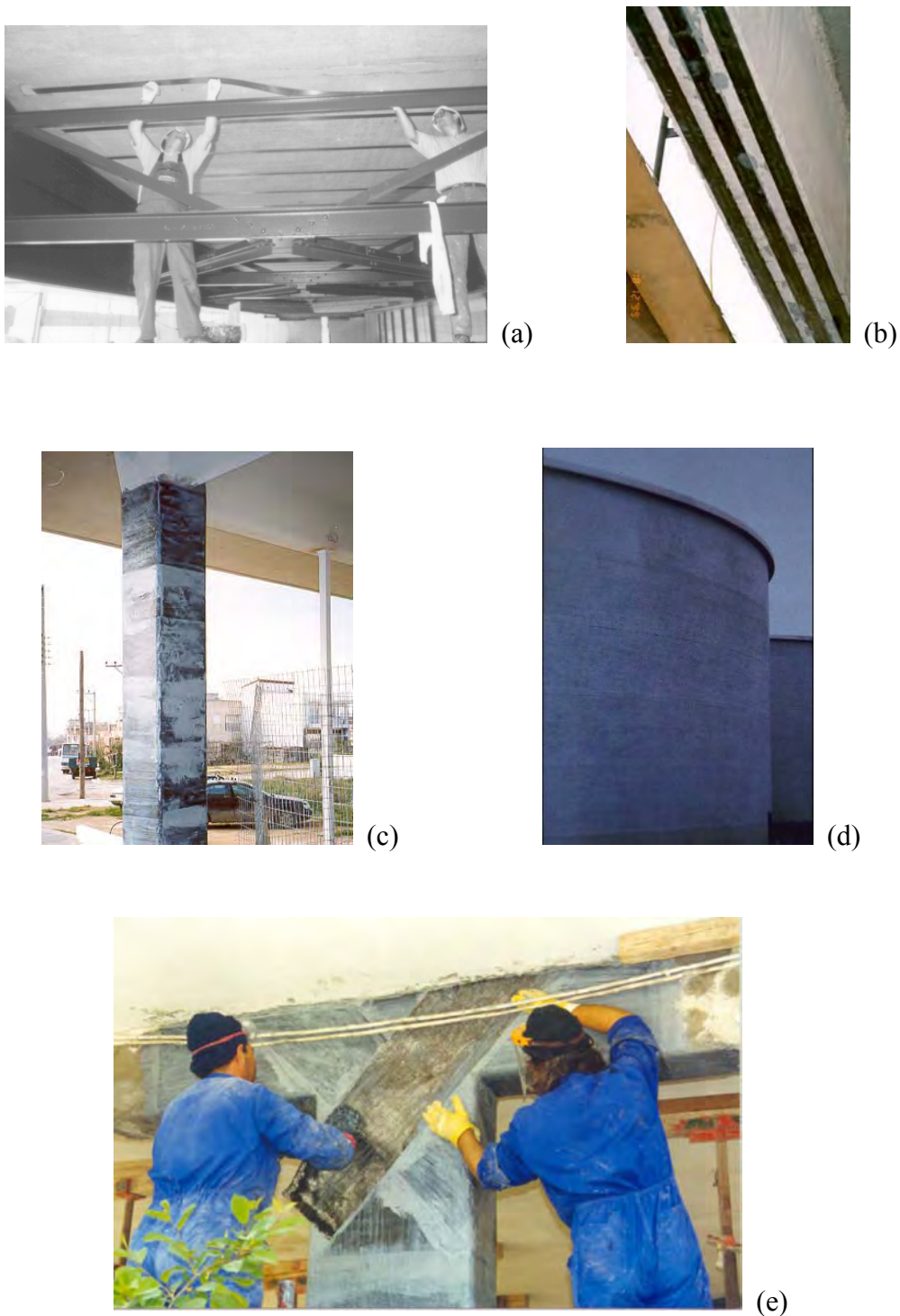

Fig. 1-2: Typical FRP applications as strengthening materials of RC structures: (a) flexural strengthening of slab; (b) flexural strengthening of beam; (c) shear strengthening and confinement of column; (d) wrapping of concrete tank; (e) shear strengthening of beam-column joint.

1.4 Content and aim of this report

In this state-of-the-art report the aim is to give an overview of the main applications of composites as externally bonded reinforcement (EBR) of concrete structures and to present guidelines for the design. Following a general description of materials and techniques related to the application of composites as external reinforcement of concrete elements, the report

contains several chapters, with each of them devoted to one particular aspect of strengthening with externally bonded FRP. Separate chapters deal with the design and structural behaviour of concrete members strengthened in *flexure*, *shear* or *torsion* as well as *confined* members. Naturally, these chapters are followed by *detailing rules* and issues of *practical execution* and *quality control*. The last chapter provides information on *special design considerations and environmental effects*.

We should emphasise that: (a) it is not the aim of this report to cover all aspects of RC strengthening with composites; (b) several of the topics presented in this report are subjects of ongoing research and development, and the details of various modelling approaches may be subjected to future revisions. Nevertheless, considerable effort has been made here to present material which is state-of-the-art in the area of composites as strengthening materials for concrete structures.

In this bulletin, several box-around values are given in the text, as in Eurocodes, the meaning being that these values may be revised in the future, if new information and data become available.

2 FRP strengthening materials and techniques

This chapter provides general information on FRP materials used in concrete strengthening, on concepts and techniques for their application, and on recently developed advanced methods of FRP applications as externally bonded reinforcement of concrete. Further details are also provided in Chapter 8 on “Practical Execution”.

2.1 Materials for FRP strengthening

2.1.1 General

The selection of materials for different strengthening systems is a critical process. Every system is unique in the sense that the fibres and the resin components are designed to work together. This implies that a resin system for one strengthening system will not automatically work properly for another. Furthermore, a resin system for the fibres will not necessarily provide a good bond to concrete. This implies that only systems that have been tested and applied in full scale on reinforced concrete structures shall be used in FRP strengthening.

Today there are several types of FRP strengthening systems, which are summarised below:

- Wet lay-up systems
- Systems based on prefabricated elements
- Special systems, e.g. automated wrapping, prestressing etc.

These systems correspond to several manufacturers and suppliers, and are based on different configurations, types of fibres, adhesives, etc. Also, the suitability of each system depends on the type of structure that shall be strengthened. For example, prefabricated strips are generally best suited for plane and straight surfaces, whereas sheets or fabrics are more flexible and can be used to plane as well as to convex surfaces. Automated wrapping can be preferable in cases when many columns need to be strengthened at the same site.

Practical execution and application conditions, for example cleanness and temperature, are very important, in achieving a good bond. A dirty surface will never provide a good bond. The adhesives undergo a chemical process during hardening that needs a temperature above 10 °C to start. If the temperature drops, the hardening process delays.

In the following sections the three main components, namely adhesives, resin matrices and fibres of an FRP strengthening material system will be discussed briefly.

2.1.2 Adhesives

The purpose of the adhesive is to provide a shear load path between the concrete surface and the composite material, so that full composite action may develop. The science of adhesion is a multidisciplinary one, demanding a consideration of concepts from such topics as surface chemistry, polymer chemistry, rheology, stress analysis and fracture mechanics. It is not our aim to cover this field in any detail. It is only to emphasise that key information about adhesives relevant to their use needs to be provided by the manufacturer of the strengthening system.

Only the most common type of structural adhesives will be discussed here, namely epoxy adhesive, which is the result of mixing an epoxy resin (polymer) with a hardener. Depending on the application demands, the adhesive may contain fillers, softening inclusions, toughening additives and others. The successful application of an epoxy adhesive system requires the

preparation of an adequate specification, which must include such provisions as adherent materials, mixing/application temperatures and techniques, curing temperatures, surface preparation techniques, thermal expansion, creep properties, abrasion and chemical resistance.

When using epoxy adhesives there are two different time concepts that need to be taken into consideration. The first is the *pot life* and the second is the *open time*. Pot life represents the time one can work with the adhesive after mixing the resin and the hardener before it starts to harden in the mixture vessel; for an epoxy adhesive, it may vary between a few seconds up to several years. Open time is the time that one can have at his/her disposal after the adhesive has been applied to the adherents and before they are joined together. Another important parameter to consider is the *glass transition temperature*, T_g . Most synthetic adhesives are based on polymeric materials, and as such they exhibit properties that are characteristic for polymers. Polymers change from relatively hard, elastic, glass-like to relatively rubbery materials at a certain temperature. This temperature level is defined as glass transition temperature, and is different for different polymers.

Epoxy adhesives have several advantages over other polymers as adhesive agents for civil engineering use, namely (Hollaway and Leeming 1999):

- High surface activity and good wetting properties for a variety of substrates
- May be formulated to have a long open time
- High cured cohesive strength; joint failure may be dictated by adherent strength
- May be toughened by the inclusion of dispersed rubbery phase
- Lack of by-products from curing reaction minimises shrinkage and allows the bonding of large areas with only contact pressure
- Low shrinkage compared with polyesters, acrylics and vinyl types
- Low creep and superior strength retention under sustained load
- Can be made thixotropic for application to vertical surfaces
- Able to accommodate irregular or thick bond lines

Typical properties for cold cured epoxy adhesives used in civil engineering applications are given in Table 2.1 (Mays and Hutchinson 1992). For the sake of comparison, the same table provides information for concrete and mild steel too.

Property (at 20 °C)	Cold-curing epoxy adhesive	Concrete	Mild steel
Density (kg/m ³)	1100 – 1700	2350	7800
Young's modulus (GPa)	0.5 - 20	20 - 50	205
Shear modulus (GPa)	0.2 – 8	8 - 21	80
Poisson's ratio	0.3 – 0.4	0.2	0.3
Tensile strength (MPa)	9 - 30	1 - 4	200 - 600
Shear strength (MPa)	10 - 30	2 - 5	200 - 600
Compressive strength (MPa)	55 - 110	25 - 150	200 - 600
Tensile strain at break (%)	0.5-5	0.015	25
Approximate fracture energy (Jm ⁻²)	200-1000	100	10 ⁵ -10 ⁶
Coefficient of thermal expansion (10 ⁻⁶ /°C)	25 - 100	11 - 13	10 - 15
Water absorption: 7 days - 25 °C (% w/w)	0.1-3	5	0
Glass transition temperature (°C)	45 - 80	---	---

Table 2-1: Comparison of typical properties for epoxy adhesives, concrete and steel (Täljsten 1994).

2.1.3 Matrices

The matrix for a structural composite material can either be of thermosetting type or of thermoplastic type, with the first being the most common one. The function of the matrix is to protect the fibres against abrasion or environmental corrosion, to bind the fibres together and to distribute the load. The matrix has a strong influence on several mechanical properties of the composite, such as the transverse modulus and strength, the shear properties and the properties in compression. Physical and chemical characteristics of the matrix such as melting or curing temperature, viscosity and reactivity with fibres influence the choice of the fabrication process. Hence, proper selection of the matrix material for a composite system requires that all these factors be taken into account (Agarwal and Broutman 1990).

Epoxy resins, polyester and vinylester are the most common polymeric matrix materials used with high-performance reinforcing fibres. They are thermosetting polymers with good processibility and good chemical resistance. Epoxies have, in general, better mechanical properties than polyesters and vinylesters, and outstanding durability, whereas polyesters and vinylesters are cheaper.

2.1.4 Fibres

A great majority of materials are stronger and stiffer in the fibrous form than as a bulk material. A high fibre aspect ratio (length/diameter ratio) permits very effective transfer of load via matrix materials to the fibres, thus enabling full advantage of the properties of the fibres to be taken. Therefore, fibres are very effective and attractive reinforcement materials. Fibres can be manufactured in continuous or discontinuous (chopped) form, but here only continuous fibres are considered. Such fibres have a diameter in the order of 5-20 μm , and can be manufactured as unidirectional or bi-directional reinforcement. The fibres used for strengthening all exhibit a linear elastic behaviour up to failure and do not have a pronounced yield plateau as for steel.

There are mainly three types of fibres that are used for strengthening of civil engineering structures, namely glass, aramid and carbon fibres. It should be recognised that the physical and mechanical properties can vary a great for a given type of fibre as well of course the different fibre types.

Glass fibres for continuous fibre reinforcement are classified into three types: E-glass fibres, S-glass and alkali resistant AR-glass fibres. E-glass fibres, which contain high amounts of boric acid and aluminate, are disadvantageous in having low alkali resistance. S-glass fibres are stronger and stiffer than E-glass, but still not resistant to alkali. To prevent glass fibre from being eroded by cement-alkali, a considerable amount of zircon is added to produce alkali resistance glass fibres; such fibres have mechanical properties similar to E-glass. An important aspect of glass fibres is their low cost.

Aramid fibres were first introduced in 1971, and today are produced by several manufacturers under various brand names. The structure of aramid fibre is anisotropic and gives higher strength and modulus in the fibre longitudinal direction. The diameter of aramid fibre is approximately 12 μm . Aramid fibres respond elastically in tension but they exhibit non-linear and ductile behaviour under compression; they also exhibit good toughness, damage tolerance and fatigue characteristics.

Carbon fibres are normally either based on pitch or PAN, as raw material. Pitch fibres are fabricated by using refined petroleum or coal pitch that is passed through a thin nozzle and stabilised by heating. PAN fibres are made of polyacrylonitrile that is carbonised through burning. The diameter of pitch-type fibres measures approximately 9-18 μm and that of the PAN-type measures 5-8 μm . The structure of this carbon fibre varies according to the

orientation of the crystals; the higher the carbonation degree, the higher the orientation degree and rigidity as a result of growing crystals. The pitch base carbon fibres offer general purpose and high strength/elasticity materials. The PAN-type carbon fibres yield high strength materials and high elasticity materials. Typical properties of various types of fibre materials are provided in Table 2.2. Note that values in this table are only indicative of static strength of unexposed fibres. Design values of the FRP composite systems should account both for the presence of resin (see “rule of mixtures” below) and for reductions due to long-term loading, environmental exposure etc. (such reductions are normally supplied by the manufacturer).

Material	Elastic modulus (GPa)	Tensile strength (MPa)	Ultimate tensile strain (%)
Carbon			
High strength	215-235	3500-4800	1.4-2.0
Ultra high strength	215-235	3500-6000	1.5-2.3
High modulus	350-500	2500-3100	0.5-0.9
Ultra high modulus	500-700	2100-2400	0.2-0.4
Glass			
E	70	1900-3000	3.0-4.5
S	85-90	3500-4800	4.5-5.5
Aramid			
Low modulus	70-80	3500-4100	4.3-5.0
High modulus	115-130	3500-4000	2.5-3.5

Table 2-2: Typical properties of fibres (Feldman 1989, Kim 1995).

2.1.5 FRP materials

FRP materials consist of a large number of small, continuous, directionalized, non-metallic fibres with advanced characteristics, bundled in a resin matrix. Depending on the type of fibre (Section 2.1.4) they are referred to as AFRP (aramid fibre based), CFRP (carbon fibre based) or GFRP (glass fibre based). Typically, the volume fraction of fibres in FRPs equals about 50-70% for strips and about 25-35% for sheets. Hence fibres are the principal stress bearing constituents, while the resin transfers stresses among fibres and protects them. Different techniques are used for manufacturing (e.g. pultrusion, hand lay-up), detailed descriptions of which are outside the scope of this bulletin. As externally bonded reinforcement for the strengthening of structures, FRP materials are made available in various forms, which are described in Section 2.2.

Basic mechanical properties of FRP materials may be estimated if the properties of the constituent materials (fibres, matrix) and their volume fraction are known. This may be accomplished by applying the “rule of mixtures” simplification as follows:

$$E_f = E_{fib} V_{fib} + E_m V_m \quad (2-1)$$

$$f_f \approx f_{fib} V_{fib} + f_m V_m \quad (2-2)$$

where E_f = Young’s modulus of FRP in fibre direction, E_{fib} = Young’s modulus of fibres, E_m = Young’s modulus of matrix, V_{fib} = volume fraction of fibres, V_m = volume fraction of

matrix, f_f = tensile strength of FRP in fibre direction, f_{fib} = tensile strength of fibres and f_m = tensile strength of matrix. Note that in the above equations $V_{fib} + V_m = 1$. Also, typical values for the volume fraction of fibres in prefabricated strips are in the order of 0.50 – 0.65.

As the rule of mixture is an approximation of the micro-mechanical behaviour of fibre composites, a more detailed prediction of the stress-strain behaviour should be obtained through tensile testing (see also Chapter 8). Hence the material properties should be given for the combined FRP directly, so to reflect the fibre and matrix characteristics as well as the micro-structural aspects such as fibre diameter, distribution and parallelism of fibres, local defects, volume fractions and fibre-matrix interfacial properties.

Material	Elastic modulus (GPa)	Tensile strength (MPa)	Ultimate tensile strain (%)
<i>Prefabricated strips</i>	E_f	f_f	ϵ_{fu}
Low modulus CFRP strips	170	2800	1.6
High modulus CFRP strips	300	1300	0.5
Mild steel	200	400	25*

* Yield strain = 0.2%

Table 2-3: Typical properties of prefabricated FRP strips and comparison with steel.

Typical FRP commercial products in the form of prefabricated strips have the properties given in Table 2-3, where the properties for mild steel area also given for comparison.

In case of prefabricated strips the material properties based on the total cross-sectional area can be used in calculations and are usually supplied by the manufacturer (see Table 2-3). In case of in-situ resin impregnated systems, however, the final FRP thickness and with that the fibre volume fraction is uncertain and may vary. For this reason a calculation based on the FRP properties for the total system (fibres and matrix) and the actual thickness is not appropriate. Note that manufacturers sometimes supply the material properties for the bare fibres. Because of this difference in approach, one should be careful when comparing properties of different systems. Furthermore it is very important that in calculations the appropriate material properties for the applied system are used. In the following the difference between both approaches is explained and elucidated with an example.

Due to the fact that the stiffness and strength of the fibres (E_{fib} and f_{fib}) is much larger than respectively the stiffness and strength of the matrix (E_m and f_m), the properties of the FRP composite material (E_f and f_f) are governed by the fibre properties and the cross-sectional area of the bare fibres. When the FRP properties are based on the total cross-sectional area (fibres and matrix) this means that, compared to the properties of the bare fibres, the stiffness and strength is less. It may be obvious that the strength and stiffness of the total system is not affected because this reduction is compensated by an increase of the cross-sectional area compared to the cross-sectional area of the fibres. So, there is a strong relation between the fibre volume fraction and the FRP properties to be used in calculations. This is illustrated in Table 2-4 and Fig. 2-1. For certain chosen properties of the fibres and the matrix, the effect of the volume fraction of the fibres on the FRP properties is shown. For a constant amount of fibres (cross-sectional area = 70 mm²) the failure load and strain at failure is only very little

affected by an increase of the amount of resin. The FRP-properties to be used in calculations based on the total cross-sectional area, however, are strongly influenced.

Chosen properties for constituent materials of FRP composite:								
$E_{fib}=220$ GPa			$f_{fib} = 4000$ MPa					
$E_m = 3$ GPa			$f_m = 80$ MPa					
Cross-sectional area			FRP-properties				Failure load	
A_{fib} (mm ²)	A_m (mm ²)	A_f^* (mm ²)	V_{fib} (%)	E_f [eq. (2-1)] (MPa)	f_f [eq. (2-2)] (MPa)	Ultimate strain (%)	(kN)	(%)
70	0	70	100	220000	4000	1.818	280.0	100.0
70	30	100	70	154900	2824	1.823	282.4	100.9
70	70	140	50	111500	2040	1.830	285.6	102.0

* In case of a strip with a width of 100 mm dividing this value by 100 mm gives the thickness of the strip (resp. 0.7 mm, 1.0 mm and 1.4 mm).

Table 2-4: Example showing the effect of volume fraction of fibres on the FRP properties.

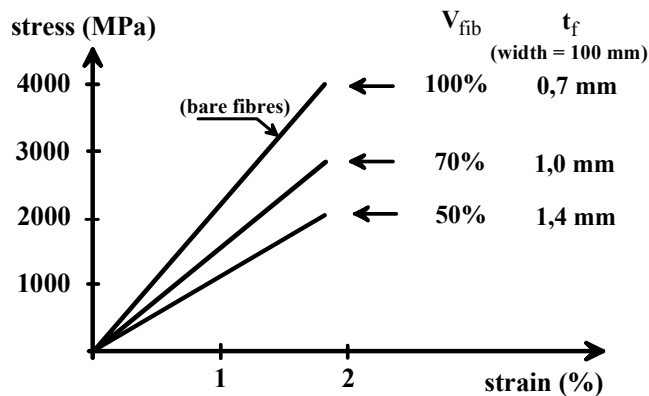

Fig. 2-1: Stress strain relations corresponding to various fibre volume fractions V_{fib} in Table 2-4.

The example given above demonstrates that for a comparison of FRP materials it may not be sufficient only to compare values for strength and/or stress-strain relations. It is important also to know the composition of the FRP material to which the given property belongs. In case of uncertainty about the thickness (like with in-situ resin impregnated systems) it may be more convenient to base calculations on the fibre properties and fibre cross-sectional area than on properties for the total system. The latter approach is still possible, however, the material properties and thickness (cross-sectional area) as specified by the manufacturer should then be used and not the actual thickness that is realised in practice.

As mentioned, in case of in-situ impregnated systems, one may calculate the properties of the FRP based on those of the bare fibres only. In this case the second term in eq. (2-1)-(2-2) may be ignored, V_{fib} should be taken equal to 1 and the dimensions of the externally bonded reinforcement (e.g. cross-sectional area) should be calculated based on the nominal dimensions of the fibre sheets. If this approach is adopted, the resulting property (e.g. elastic modulus, tensile strength) should be multiplied by a reduction factor r , to account for the efficiency of the fibre-resin system and for the sheet or fabric architecture. This factor should be provided by the FRP system supplier based on testing. Alternatively, the FRP supplier could provide directly the properties of the in-situ impregnated system (e.g. thickness, elastic modulus, tensile strength) based on testing. To illustrate this, we may assume that a sheet has

a nominal thickness t_{fib} and elastic modulus E_{fib} (both calculated based on bare fibre properties). After impregnation, the FRP has a thickness t_f and an elastic modulus E_f . The two systems are equivalent according to the condition: $t_{\text{fib}}E_{\text{fib}} = t_fE_f$.

2.2 FRP EBR systems

Different systems of externally bonded FRP reinforcement (FRP EBR) exist, related to the constituent materials, the form and the technique of the FRP strengthening. In general, these can be subdivided into “wet lay-up” (or “cured in-situ”) systems and “prefab” (or “pre-cured”) systems. In the following, an overview is given of the different forms of these systems (e.g. ACI 1996). Techniques for FRP strengthening are given in Section 2.3.

2.2.1 Wet lay-up systems

- Dry unidirectional fibre *sheet* and semi-unidirectional *fabric* (woven or knitted), where fibres run predominantly in one direction partially or fully covering the structural element. Installation on the concrete surface requires saturating resin usually after a primer has been applied. Two different processes can be used to apply the fabric:
 - the fabric can be applied directly into the resin which has been applied uniformly onto the concrete surface,
 - the fabric can be impregnated with the resin in a saturator machine and then applied wet to the sealed substrate.
- Dry multidirectional *fabric* (woven or knitted), where fibres run in at least two directions. Installation requires saturating resin. The fabric is applied using one of the two processes described above.
- Resin pre-impregnated uncured unidirectional *sheet* or *fabric*, where fibres run predominantly in one direction. Installation may be done with or without additional resin.
- Resin pre-impregnated uncured multidirectional *sheet* or *fabric*, where fibres run predominantly in two directions. Installation may be done with or without additional resin.
- Dry fibre *tows* (untwisted bundles of continuous fibres) that are wound or otherwise mechanically placed onto the concrete surface. Resin is applied to the fibre during winding.
- Pre-impregnated fibre *tows* that are wound or otherwise mechanically placed onto the concrete surface. Product installation may be executed with or without additional resin.

2.2.2 Prefabricated elements

- Pre-manufactured cured straight *strips*, which are installed through the use of adhesives. They are typically in the form of thin ribbon strips or grids that may be delivered in a rolled coil. Normally strips are pultruded. In case they are laminated, also the term *laminates* instead of *strip* may be used.
- Pre-manufactured cured shaped *shells*, *jackets* or *angles*, which are installed through the use of adhesives. They are typically factory-made curved or shaped elements or split shells that can be fitted around columns or other elements.

2.3 Techniques for FRP strengthening

2.3.1 Basic technique

The basic FRP strengthening technique, which is most widely applied, involves the manual application of either wet lay-up (so-called hand lay-up) or prefabricated systems by means of cold cured adhesive bonding. Common in this technique is that the external reinforcement is bonded onto the concrete surface with the fibres as parallel as practically possible to the direction of principal tensile stresses. Typical applications of the hand lay-up and prefabricated systems are illustrated in Fig. 2.2. More details on the basic technique are provided in Chapter 8.



Fig. 2-2: (a) Hand lay-up of CFRP sheets or fabrics. (b) Application of prefabricated strips.

2.3.2 Special techniques

Besides the basic technique, several special techniques have been developed. Without aiming to provide a complete overview of these special techniques, a number of them are briefly explained in the following sections.

Some of the special techniques described below are patented by the companies that developed them.

2.3.2.1 Automated wrapping

The FRP strengthening technique through automated winding of tow or tape was first developed in Japan in the early 90s and a little later in the USA. The technique, shown in Fig. 2-3, involves continuous winding of wet fibres under a slight angle around columns or other structures (e.g. chimneys, as has been done in Japan) by means of a robot. Key advantage of the technique, apart from good quality control, is the rapid installation.

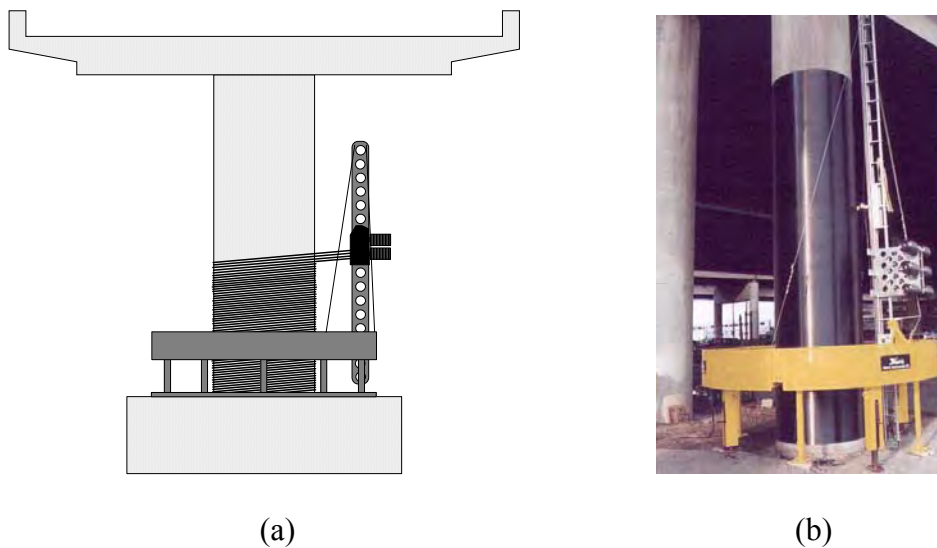

Fig. 2-3: Automated RC column wrapping. (a) Schematic. (b) Photograph of robot-wrapper.

2.3.2.2 Prestressed FRP

In some cases it may be advantageous to bond the external FRP reinforcement onto the concrete surface in a prestressed state. Both laboratory and analytical research (e.g. Triantafillou et al. 1992, Deuring 1993) shows that prestressing represents a significant contribution to the advancement of the FRP strengthening technique, and methods have been developed to prestress the FRP composites under real life conditions (Luke et al. 1998).

Prestressing the strips prior to bonding has the following advantages:

- provides stiffer behaviour as at early stages most of the concrete is in compression and therefore contributing to the moment of resistance.
- crack formation in the shear span is delayed and the cracks when they appear are more finely distributed and narrower (crack widths are also a matter of bond properties).
- closes cracks in structures with pre-existing cracks.
- improves serviceability and durability due to reduced cracking.
- improves the shear resistance of member as the whole concrete section will resist the shear, provided that the concrete remains uncracked.
- the same strengthening is achieved with smaller areas of stressed strips compared with unstressed strips.
- with adequate anchorage, prestressing may increase the ultimate moment of resistance by avoiding failure modes associated with peeling-off at cracks and the ends of the strips.
- the neutral axis remains at a lower level in the prestressed case than in the unstressed one, resulting in greater structural efficiency.
- prestressing significantly increases the applied load at which the internal steel begins to yield compared to a non-stressed member.

The technique has also some disadvantages:

- it is more expensive than normal strip bonding due to the greater number of operations and equipment that is required.
- the operation also takes somewhat longer.
- the equipment to push the strip up to the soffit of the beam must remain in place until the adhesive has hardened sufficiently.

The concept for applying a prestressed FRP strip is shown schematically in Fig. 2-4 and a schematic illustration of the stressing device is given in Fig. 2-5.

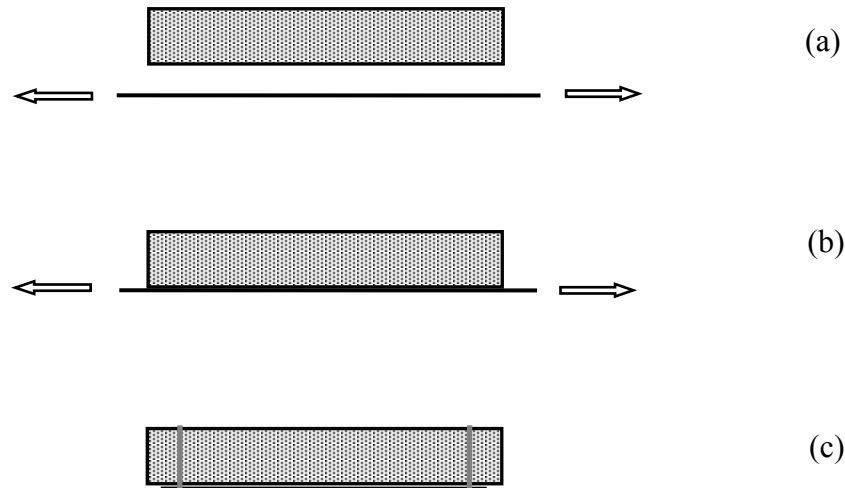

Fig.2-4: Strengthening with prestressed FRP strips: (a) prestressing; (b) bonding; (c) end anchorage and FRP release upon hardening of the adhesive.

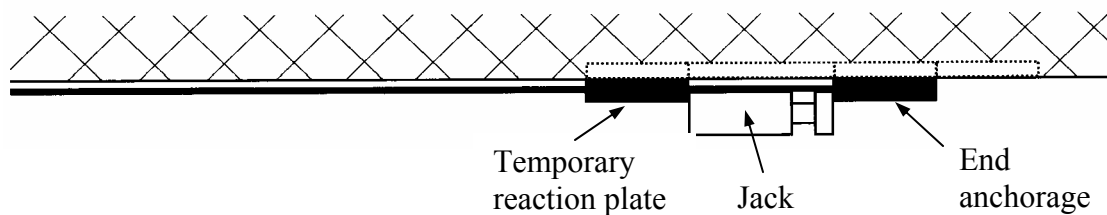

Fig.2-5: Schematic illustration of active anchorage.

When the prestressing force is too high, failure of the beam due to release of the prestressing force will occur at the two ends, due to the development of high shear stresses in the concrete just above the FRP. Hence the design and construction of the end zones requires special attention. Tests and analysis have shown that if no special anchorages are provided at the ends, FRP strips shear-off (from the ends) with prestress levels in the order of only 5-6% of their tensile strength (for CFRP). But a technically and economically rational prestress would require a considerably higher degree of prestressing, in the range of 50% of the FRP tensile strength, which may only be achieved through the use of special anchorages applying vertical confinement (see Fig. 2-4 c). Such systems have been developed for practical applications as well as research purposes.

Prestressing of column jackets (active confinement) can be achieved by pretensioning the fibre bundles during winding or with unstressed jackets by making use of, e.g., expansive mortar or injection of mortar or epoxy under pressure.

2.3.2.3 Fusion-bonded pin-loaded straps

Another interesting development of the FRP strengthening technique involves replacing solid and relatively thick strips (Fig. 2-6 a) by the system shown in Fig. 2-6 b, known as pin-loaded strap (Winistoerfer and Mottram 1997). The strap comprises a number of non-laminated layers formed from a single, continuous, thin tape, which consists of fibres in a *thermoplastic* matrix. The outside, final layer of the tape is fixed to the previous layer by a

fusion bonding process. Such a system enables the individual layers to move relative to each other, thus reducing the unwanted secondary bending stresses. Careful control of the initial tensioning process allows interlaminar shear stress concentrations to be reduced, so that a uniform strain distribution in all layers is achieved.

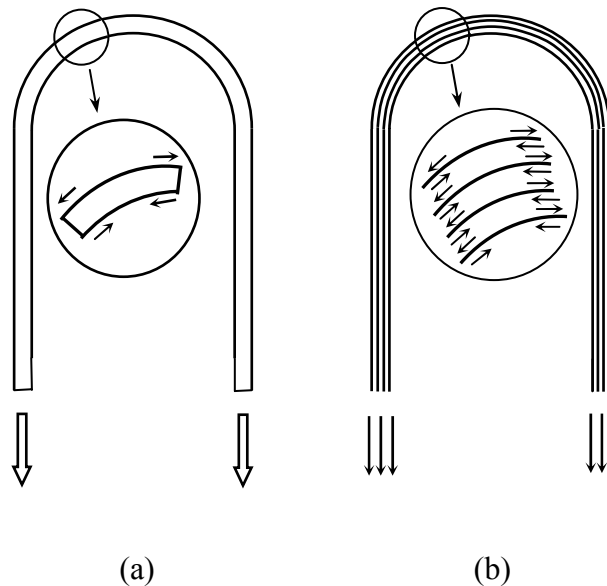

Fig. 2-6: Wrapping with (a) thick strips and (b) non-laminated straps.

2.3.2.4 In-situ fast curing using heating device

Instead of cold curing of the bond interface (curing of the two-component adhesive under environmental temperature), heating devices can be used. In this way it is possible to reduce curing time, to allow bonding in regions where temperatures are too low to allow cold curing, to apply the technique in winter time, to work with prepreg FRP types, etc.

Different systems for heating can be used, such as electrical heaters, IR (infrared) heating systems and heating blankets. For CFRP the system illustrated in Fig. 2-7 is also possible. This system takes advantage of the electrical conductivity of carbon fibres. It uses a special heating device to pass an electric current through CFRP strips during the strengthening process. The control unit allows the desired curing temperature to be maintained within a narrow range.

Controlled fast curing enables not only rapid application of the strengthening technique (e.g. full curing at 70 °C may be achieved in 3 hours) but also increases the glass transition temperature of the adhesive.

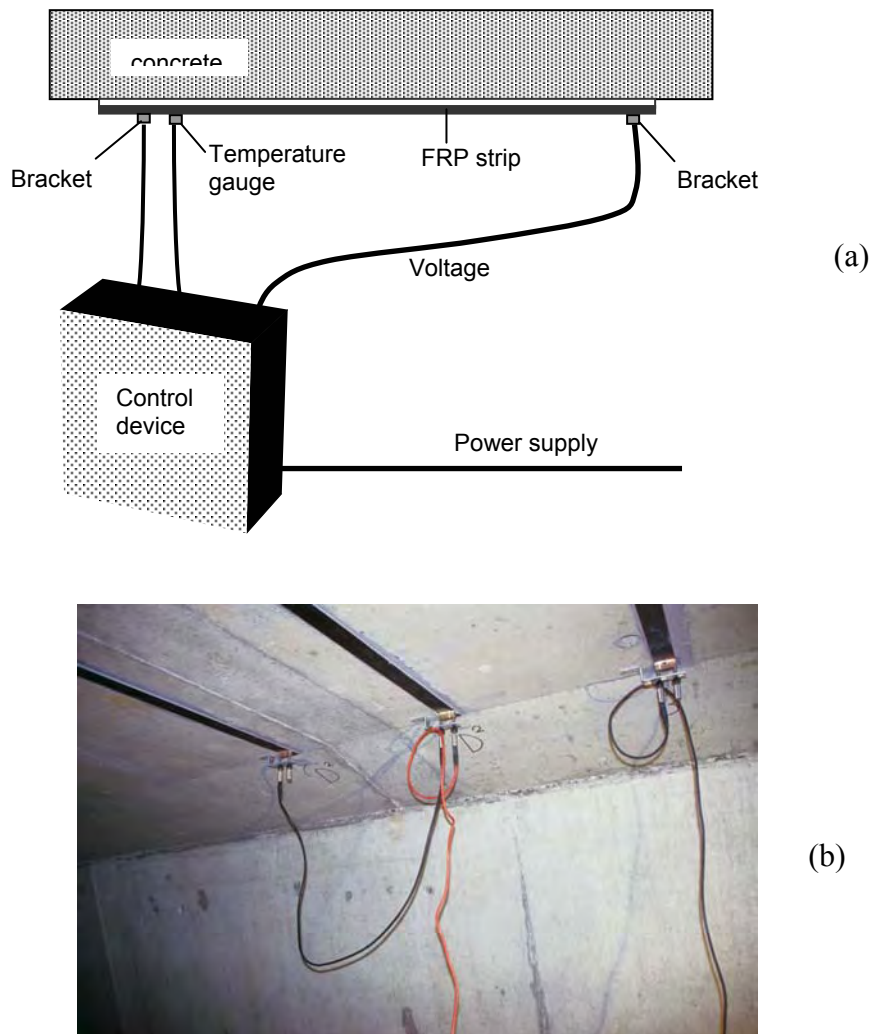

Fig. 2-7: Fast curing using heating device: (a) Schematic, (b) Photograph of end brackets.

2.3.2.5 Prefabricated shapes

Prefab type of FRP EBR systems are mostly applied in the form of straight strips. However, these prefab systems can also be produced in other forms, depending on the foreseen application. By shaping them, prefab systems can be employed in applications where normally the more flexible wet lay-up systems are used. For shear strengthening of beams, pre-manufactured angles can be used as shown in Fig. 2-8 a-b. Figure 2-8 c shows prefab shells or jackets which can be used for the confinement of circular and rectangular columns. In this case, the shells should be fabricated with sufficiently small tolerances. For new structures, FRP castings may be used. These act as formwork during construction, and as external reinforcement for the loaded structure.



(a)



(b)

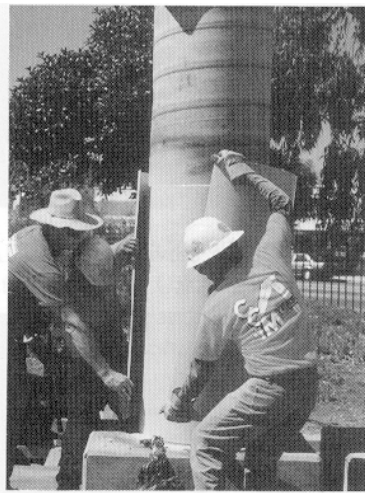

(c)

Fig. 2-8: Examples of prefab shapes for strengthening. (a) angle, (b) application of angles, (c) shell.

2.3.2.6 CFRP inside slits

CFRP in concrete slits may be thought of as a special method of supplementing reinforcement to concrete structures. The slits are cut into the concrete structure with a depth smaller than the concrete cover. CFRP strips e.g. with a thickness of 2 mm and a width of 20 mm are bonded into these slits (Fig. 2-9).

Bond tests and beam tests have been carried out to study the mechanical behaviour of the system (Blaschko and Zilch 1999). It was shown that a higher anchoring capacity compared with CFRP strips glued onto the surface of a concrete structure is obtained. The mechanical behaviour is stiffer under serviceability loads but more ductile in the ultimate limit state. The tensile strength of the CFRP can be reached in beams with additional reinforcement consisting of strips in slits, if there is enough load carrying capacity of the compression zone in the concrete and for shear. The bond behaviour with high strength and ductility allows to bridge wide cracking without peeling-off. Moreover the strips are protected against demolition. So the CFRP material can be used more efficiently if it is glued into slits instead of on the surface.

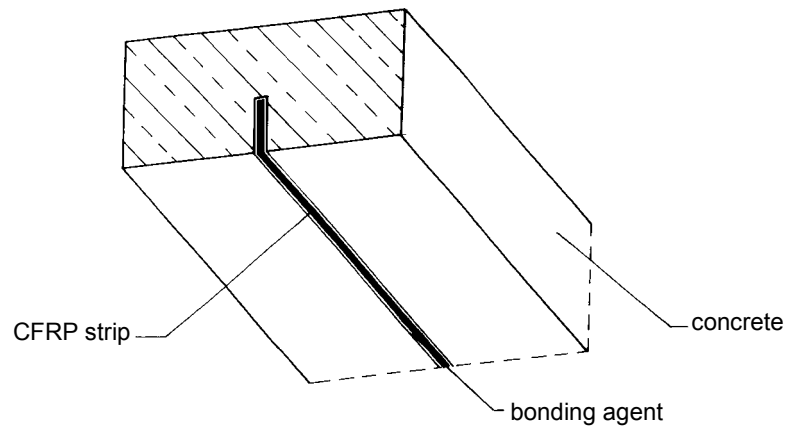

Fig. 2-9: CFRP strips glued into slits.

2.3.2.7 FRP impregnation by vacuum

FRP impregnation by vacuum is quite common in the plastics industry. Vacuum impregnation is, to some extent, comparable with wet lay-up. The concrete element to be strengthened according to this method is pre-treated in the same manner as for the other methods (i.e. through sandblasting, grinding or water blasting). The surface is cleaned carefully, primer is applied and after curing of the primer the fibres are placed in predetermined directions. It is important that sheets or fabrics have channels where the resin can flow, otherwise special spacing material must be used. A vacuum bag is placed on top of the fibres, the edges of the bag are sealed and a vacuum pressure is applied (Täljsten and Elfgren 2000). Two holes are made in the vacuum bag, one for the outlet where the vacuum pressure is applied and one for the inlet where the resin is injected (Fig. 2-10). In order to achieve an acceptable vacuum pressure, a special sealant of epoxy putty can be used along the sides of the beam at the underside of the vacuum bag. Sealing must be effective to a very high level.

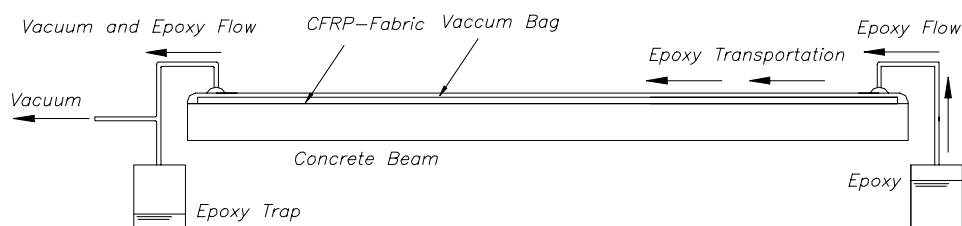

Fig. 2-10: Strengthening with vacuum injection system (Täljsten and Elfgren 2000).

Vacuum impregnation has several advantages over traditional wet lay-up. The first advantage is that with this method it is possible to avoid hand contact with the epoxy adhesive and waste at the work site can be kept to a minimum. Furthermore, the quality of the composite can be improved. However, this method requires a large investment and there can be some difficulties in achieving a high degree of vacuum with surfaces of rough texture or in complicated geometries and locations. This implies higher costs for the strengthening work. For this application, a low viscosity cold-cured epoxy adhesive is used.

3 Basis of design and safety concept

Externally bonded FRP reinforcement (FRP EBR) is an efficient technique that can be applied for a wide range of structures and materials. However, following the scope of this bulletin (Chapter 1), the basis of design and safety concept refers to the use of FRP EBR for repair and strengthening of reinforced concrete structures only.

3.1 Basis of design

3.1.1 General requirements

Strengthening of concrete structures by means of externally bonded reinforcement (EBR) is an efficient technique that relies on the composite action between a reinforced or prestressed concrete element and the externally bonded reinforcement. To guarantee the overall structural safety of the strengthened member it is important that proper FRP EBR systems are used, correctly designed, detailed and executed. The state of the member before strengthening is of influence and may require repair techniques preceding the execution of the FRP EBR system. Hence, whereas specifications in this document reflect on the design and execution of the externally bonded reinforcement specifically, related documents concerning the design of RC and PC members, among which Eurocode 2 (EC2) (CEN 1991), and concerning repair techniques will apply as well.

Various FRP EBR systems are available which differ depending on type of FRP, type of adhesive, method of curing, material preparations, etc. It should be ensured that only approved FRP EBR systems are used. The use of FRP EBR systems of insufficient quality (with respect to the constituent materials, the system and the execution) will compromise structural safety. To avoid this, products, systems and staff should fulfil quality control specifications (see Chapter 8). Quality control procedures should be adopted with respect to production, design, execution and in-service behaviour.

As the design combines and involves different structural aspects and as different FRP EBR systems are available, the project engineer should have sufficient experience in the design of structural repairs and should have knowledge about the materials and systems, the expected structural response and the related safety or risk aspects.

3.1.2 Design requirements

3.1.2.1 General

All necessary design situations and load combinations should be considered. In the design the relevant limit states should be addressed. The design of the FRP EBR has to reflect the effects of the additional reinforcement provided to the section (designed assuming full composite action) and the ability of transferring forces by means of the bond interface (verification of debonding). In addition, detailing rules and special provisions need to be considered. Design calculations are based on analytical or (semi-) empirical models.

The state of the (repaired) structure prior to strengthening should be taken as a reference for the design of the externally bonded FRP reinforcement. By means of field inspection, review of existing documents and a structural analysis, the state of the existing member or structure should be verified. As the application of the FRP EBR system is not intended to confine or arrest defects (such as e.g. steel corrosion), possible damage or deterioration is to

be identified and causes of deficiencies should be known. If needed, proper repair should be undertaken.

Due to the lack of plasticity in the FRP, redistribution of moments in the strengthened parts of members is, in general, not allowed, unless sufficient confinement of the concrete is provided, to allow for plastic deformations. Finally, for strengthened members such as columns and walls, the effect of out-of-plane deformations (second order effects) should be considered in the design.

3.1.2.2 Limit states and design situations

The design procedure should consist of a verification of both the serviceability limit state (SLS) and the ultimate limit state (ULS). In some cases it may be expected that the SLS will be governing for the design (see 3.1.2.3).

The following design situations have to be considered:

- persistent situation, corresponding to the normal use of the structure
- accidental situation, corresponding to unforeseen loss of the FRP EBR (due to e.g. impact, vandalism, fire)
- special design considerations (e.g. bond stresses due to differences in coefficient of thermal expansion, fire resistance, impact resistance).

3.1.2.3 Verification of the SLS

It should be demonstrated that the strengthened member or structure performs adequately in normal use. To meet this requirement, the SLS verification normally concerns:

- stresses; these have to be limited in order to prevent steel yielding, damage or excessive creep of concrete and excessive creep or creep rupture of the FRP
- deformations or deflections; which may restrict normal use of the structure, induce damage to non load-bearing members or negatively influence the appearance
- cracking (including interface bond cracking); which may damage the durability, functionality and appearance of the structure or which may endanger the integrity of the bond interface between FRP EBR and concrete

If the reasons for strengthening are related to improved serviceability, the SLS will be governing for the design, rather than the ULS. Even if the reason for strengthening is dictated by strength increase considerations, it may arise for flexural members that the SLS is governing for the design. Indeed, as FRP materials have high strength, small cross-sectional areas of FRP are needed for ULS. In order to meet the serviceability criteria, these areas may be insufficient, especially given the relative low modulus of elasticity of some FRPs.

Load combinations for SLS as specified in EC2 (CEN 1991) apply. Partial safety factors for the materials γ_M are taken equal to 1.0, except if specified otherwise. The stress-strain behaviour of FRP for SLS verifications is given in Section 3.1.3.1.

Provisions for the calculation of the SLS are given in the different chapters of this bulletin. Detailed calculations are not obligatory in the case limit measures and detailing rules as specified in the respective sections on the SLS are considered.

3.1.2.4 Verification of the ULS

In ULS, the different failure modes that may occur have to be considered. In general, the failure modes can be subdivided to those assuming full composite action between the RC/PC

member and the EBR system (adequate bonding) and those verifying the different debonding mechanisms that may occur.

Load combinations and partial safety factors (load factors γ_F and material factors γ_M) for ULS as specified in EC2 (CEN 1991) apply, unless specified otherwise. The material safety factor γ_f and the stress-strain behaviour of FRP for ULS verifications are given in Section 3.1.3.2. Material safety factors with respect to ULS verification of bond failure are given in Section 3.1.3.3. Provisions for the calculations in ULS are given in the different chapters of this bulletin.

3.1.2.5 Accidental situation

The accidental design situation is a verification in which loss of the FRP due to e.g. impact, vandalism or fire is assumed. The unstrengthened member is subjected to all relevant accidental load combinations of the strengthened member. This verification is performed in the ultimate limit state, considering the partial safety factors for the materials to be 1.0 and considering reduced partial safety coefficients and combination factors for the loads, as provided in Eurocode 1 (EC1), Part 1 (CEN 1994).

3.1.2.6 Special design considerations

Special design considerations such as cyclic loading, extra bond stresses due to the difference in thermal expansion between FRP and concrete, impact and fire resistance may be relevant. These aspects strongly depend on the in-situ situation and may influence both the design and the practical execution. From the above it may be obvious that impact and fire can be regarded as an accidental situation as well as a special design consideration. In the case of the accidental situation, the consequences of loss of FRP strengthening are considered and special precautions with respect to impact and fire may not be required. When on the other hand the FRP EBR has to fulfil certain requirements under impact and fire loading, this is regarded as special design consideration.

It is important that sufficient attention is paid to the special design aspects, as they can have a considerable influence on the structural safety. Provisions with respect to the special design considerations are given in Chapter 9.

3.1.2.7 Durability

The environmental conditions must be taken into account from the start of the design process, so that their influences with respect to the durability are considered and if needed protective measures can be taken. Further guidance with respect to durability is given in Chapter 9.

3.1.3 Models for the constituent materials and partial safety factors

For the design verification, the stress-strain models and associated material safety factors γ_M given in this section can be assumed. For the load safety γ_F and load combination factors ψ reference is made to EC1 (CEN 1994) and EC2 (CEN 1991). However, other action safety factors may be proposed in the future (subject to further study).

3.1.3.1 SLS verification

For SLS verifications, a linear stress-strain response is considered for the constituent materials and the partial safety factors of the materials γ_M are taken equal to 1.0. In the case of FRP, reference will be made to the following relationship:

$$\sigma_f = E_{fk} \varepsilon_f \quad (3-1)$$

where E_{fk} is the characteristic value of the secant modulus of elasticity. The latter is determined between 10 % and 50 % of the FRP ultimate strength.

Normally, the lower bound characteristic value $E_{fk0.05}$ (5 % fractile) is used for the design. In some verifications, when a higher E-modulus results in lower reliability, it is necessary to refer to the upper bound value $E_{fk0.95}$ (95 % fractile). When the E-modulus is not considered as a fundamental variable in the equation, reference may be made to the mean value E_{fm} .

3.1.3.2 ULS verification, full composite action between concrete and FRP EBR

For the ULS verification, reference is made to the design stress-strain curves of the constituent materials, as shown in Fig. 3-1.

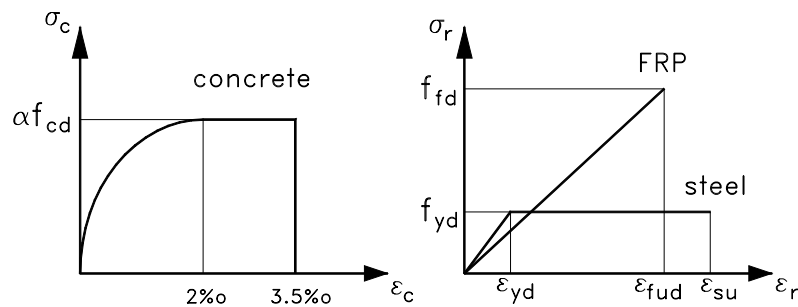

Fig. 3-1: Design stress-strain curves of constitutive materials at ULS.

For the concrete, a parabolic-rectangular stress block or alternative stress-strain relationships can be assumed, as provided by EC2. The design strength of the concrete $\alpha f_{cd} = \alpha f_{ck} / \gamma_c$ is based on the characteristic value of the compressive strength f_{ck} , a partial safety factor $\gamma_c = 1.5$ and a reduction factor $\alpha = 0.85$ to account for the reduced compressive strength under long-term loading. For the steel reinforcement, a bilinear stress-strain relationship is considered, with a design yield strength $f_{yd} = f_{yk} / \gamma_s$. The material safety factor γ_s equals 1.15. More details on the stress-strain curves, characteristic and design values of the concrete and steel can be found in EC2 (CEN 1991).

The tensile stress-strain behaviour of the FRP for ULS verifications can be idealised by means of a linear response, defined as (Fig. 3-1):

$$\sigma_f = E_{fu} \varepsilon_f \leq f_{fd} \quad (3-2)$$

where $E_{fu} = f_{fk} / \varepsilon_{fuk}$ is the modulus of elasticity at ultimate, based on the characteristic values of the FRP tensile strength and ultimate strain. The characteristic strength f_{fk} corresponds to the 5 % fractile of the tensile strength and ε_{fuk} is the 5 % fractile of the failure strain. It is

noted that the modulus of elasticity E_{fu} is normally higher than the secant modulus E_{fk} (as the fibres, which are not perfectly aligned initially, straighten at higher load levels, the stiffness of the FRP increases). Nevertheless, this should be verified and E_{fu} shall not be taken less than $E_{fk0.05}$.

When the design is governed by the SLS or an ULS corresponding with concrete crushing or bond failure, the FRP strain at ultimate is rather limited. In this situation, which will often be the case, the FRP stress σ_f at ULS is considerably lower than the tensile strength, so that the design tensile strength is generally not governing. To verify this or hence in those cases where the ULS is determined by FRP tensile failure anyway, reference is made to the design tensile strength f_{fd} :

$$f_{fd} = \frac{f_{fk} \cdot \varepsilon_{fue}}{\gamma_f \cdot \varepsilon_{fum}} \quad (3-3)$$

Values for the FRP material safety factor γ_f are suggested in Table 3.1. These are mainly based on the observed differences in the long-term behaviour of FRP (basically depending on the type of fibres), as well as on the influence of the application method. The proposed factors are (because of lack of comprehensive data) subject to further study. The ratio $\varepsilon_{fue}/\varepsilon_{fum}$ normally equals 1, as the effective ultimate FRP strain ε_{fue} expected in-situ will not significantly differ from the mean strain ε_{fum} obtained through uniaxial tensile testing, and as small variations are accounted for in the FRP material safety factor γ_f . However in particular cases, the effective failure strain ε_{fue} may be significantly lower as result of wrapping of FRP around very sharp corners, application of a large number of layers, multi-axial state of stress, etc. A limited value of the FRP failure strain may also be considered as a simplified design alternative. In this case, the ULS verification restricts excessive FRP deformations, rather than verifying the related failure mode itself. Further details on the effective failure strain ε_{fue} (if applicable) are provided in the respective chapters of this bulletin or should be based on experimental evidence.

For the stress-strain relationship of FRP confined concrete, reference is made to Chapter 6.

Table 3-1: FRP material safety factors γ_f .

FRP type	Application type A ⁽¹⁾		Application type B ⁽²⁾	
CFRP	1.20		1.35	
AFRP	1.25		1.45	
GFRP	1.30		1.50	

⁽¹⁾ Application of prefab FRP EBR systems under normal quality control conditions. Application of wet lay-up systems if all necessary provisions are taken to obtain a high degree of quality control on both the application conditions and the application process.

⁽²⁾ Application of wet lay-up systems under normal quality control conditions. Application of any system under difficult on-site working conditions.

3.1.3.3 ULS verification of bond failure

Bond failures may be caused by different reasons as demonstrated in Chapter 4. Assuming proper application of the FRP EBR and the use of suitable materials, the bond failure will normally occur in the concrete. In the ULS verification, reference will be made to the design tensile or shear strength of the concrete, by introducing a material safety factor, designated γ_{cb} . A factor γ_{cb} equal to 1.5 is proposed (similar to $\gamma_c = 1.5$ [EC2]).

In particular cases, e.g. for high strength concrete, the shear strength of the adhesive can be lower than the shear strength of the concrete. In the ULS verification, reference will be made to the design tensile or shear strength of the adhesive, by considering a material safety factor $\gamma_a = 1.5$. The proposed factors γ_{cb} and γ_a are (because of lack of comprehensive data) subject to further study.

Higher FRP tensile stresses ($\sigma_f = E_f \epsilon_f$) will result in higher bond forces. Hence, the verification of bond failure should be related to an upper bound value of the modulus of elasticity E_f . The latter can be taken equal to the maximum of:

- the modulus of elasticity E_{fu} at ultimate (although bond failure may occur at FRP strains considerably lower than the ultimate FRP strain)
- the upper bound value of the characteristic secant modulus $E_{fk0.95}$.

3.2 Safety concept

The design should be such that sufficient structural safety is obtained, including sufficient ductility. The latter aspect is discussed in Section 3.3.

3.2.1 Safety concept with respect to the ultimate limit state

In the ultimate limit state, the modelling will be related to the different failure modes that may occur. Design should be such that brittle failure modes, such as shear and torsion, are excluded. For the same reason, it should be guaranteed that the internal steel is sufficiently yielding in ULS (see Section 3.3), so that the strengthened member will fail in a ductile manner, despite the brittle nature of concrete crushing, FRP rupture or bond failure. Hence, the governing failure mode of a flexural member will be either steel yielding/concrete crushing (before FRP rupture or debonding) corresponding with zone B in Fig. 3-2, or steel yielding/FRP failure (either FRP rupture or bond failure) corresponding with zone A in Fig. 3-2. In Fig. 3-2, ϵ_o is the initial strain at the extreme tensile fibre before strengthening, $\epsilon_{f,min}$ is the minimum allowable FRP strain at ultimate (Section 3.3) and $\epsilon_{fu,c}$ is the FRP strain in the critical section at ultimate. In case FRP fracture is governing, $\epsilon_{fu,c}$ equals the design value of the ultimate FRP strain ϵ_{fud} . In case of bond failure, $\epsilon_{fu,c}$ equals the FRP strain in the critical section when debonding occurs. This debonding may initiate at another location than the critical section that is considered for the verification of the flexural capacity. Bond failure will be allowed in the design if $\epsilon_{fu,c} \geq \epsilon_{f,min}$. Optimum design will correspond with simultaneous concrete crushing ($\epsilon_{cu} = 0.0035$) and FRP tensile failure (ϵ_{fud}) (Fig. 3-2).

For flexural members often the SLS will be governing in the design (as mentioned in Section 3.1.2.3). This implies that larger amounts of FRP will be applied than needed for ULS. Generally, this will positively influence the ratio of ultimate load to service load.

In all cases, it should be verified that the shear (or torsion) capacity of the strengthened member is larger than the acting shear (or torsion) forces. If needed, flexural strengthening must be combined with shear strengthening.

For tensile members, optimum design in ULS will correspond with FRP rupture. Bond failure will strongly reduce the load-bearing capacity of the tensile member. In any case, the design should guarantee sufficient yielding of the internal steel (Section 3.3).

For compression members, strengthening is done by confinement (Chapter 6). This technique favourably influences the structural safety as confinement results in increased ductility.

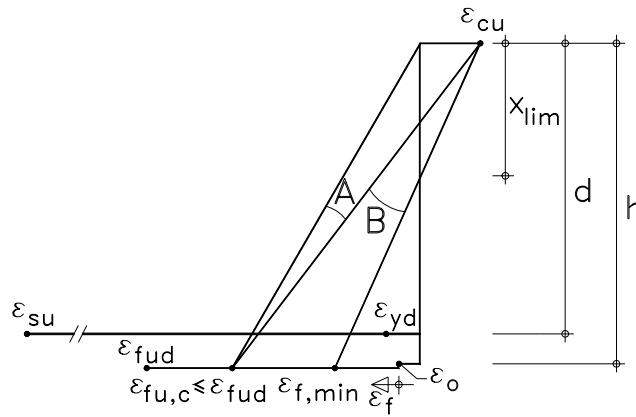

Fig. 3-2: Strain distribution at ULS in the critical section of strengthened flexural members.

3.2.2 Safety concept with respect to accidental design situation

It is sometimes suggested that the FRP EBR should serve as secondary reinforcement, so that in case of accidental loss of the FRP strengthening, the existing structure can still continue to support all relevant load combinations without (total) collapse of the structure. This verification is based on an accidental design situation (see Section 3.1.2.5).

If the accidental design situation is fulfilled, structural safety is maximised with respect to loss of the externally bonded reinforcement. In this case, special design considerations such as vandalism, impact or fire are generally no longer of concern, or they are of minor importance.

On the other hand, it can be argued that the accidental design situation restricts the maximum strength increase, while sufficient evidence is available to rely on the externally bonded FRP reinforcement not only as secondary reinforcement. In this case, extra attention should be paid to the special design considerations mentioned above.

In any event, the strength increase of properly designed strengthened members can be limited not only by the ULS, but by the SLS and the ductility requirements as well. It may be that the latter requirements govern the maximum strength increase rather than the accidental design situation.

3.3 Ductility

Generally, the ductility of a strengthened tensile or flexural member decreases with respect to the unstrengthened member. This will be the case especially for premature debonding failures and high strengthening ratios, as small FRP strains and hence small deformations or curvatures are obtained at ultimate.

To guarantee adequate ductility of strengthened flexural members, the internal steel should sufficiently yield at failure, i.e. the curvature (or deflection) at ultimate should be large enough. With respect to this issue, EC2, Section 2.5.3.4.2 (5) (CEN 1991) gives the following limitation on the depth of the compression zone at ultimate:

$$\begin{aligned} \xi &\leq \boxed{0.45} \text{ for concrete types C35/45 or lower} \\ \xi &\leq \boxed{0.35} \text{ for concrete types higher than C35/45} \end{aligned} \quad (3-4)$$

where $\xi = x/d$, with x the depth of the compression zone and d the effective beam depth.

Based on eq. (3-4) and Fig. 3-2, with the ultimate concrete strain $\varepsilon_{cu} = 0.0035$ and $h/d \approx 1.1$, the following requirement can be formulated, in terms of the minimum FRP strain at ultimate:

$$\begin{aligned} \varepsilon_{fu,c} &\geq \boxed{0.0050} - \varepsilon_0 \text{ for concrete types C35/45 or lower} \\ \varepsilon_{fu,c} &\geq \boxed{0.0075} - \varepsilon_0 \text{ for concrete types higher than C35/45} \end{aligned} \quad (3-5)$$

with $\varepsilon_{fu,c}$ the FRP strain in the critical section at ultimate.

In terms of a minimum strain in the internal steel reinforcement at ultimate, eq. (3-4) corresponds with:

$$\begin{aligned} \varepsilon_{su,c} &\geq \boxed{0.0043} \text{ for concrete types C35/45 or lower} \\ \varepsilon_{su,c} &\geq \boxed{0.0065} \text{ for concrete types higher than C35/45} \end{aligned} \quad (3-6)$$

where $\varepsilon_{su,c}$ is the steel strain in the critical section at ultimate. Based on steel grade S500 (characteristic yield strain $\varepsilon_{yk} = 0.0025$), this means that the steel strain $\varepsilon_{su,c}$ should equal at least 1.7 or 2.6 times the yield strain. Hence, the minimum curvature ductility index can be approximated as:

$$\begin{aligned} \delta_{\chi,\min} &\approx \boxed{1.7} \text{ for steel S500 and concrete types C35/45 or lower} \\ \delta_{\chi,\min} &\approx \boxed{2.6} \text{ for steel S500 and concrete types higher than C35/45} \end{aligned} \quad (3-7)$$

where δ_{χ} is equal to the curvature at failure χ_u divided by the curvature at yield χ_y . For tensile members, strains at ultimate should meet the condition given in eq. (3-6).

The amount of internal steel should meet the minimum specified in Chapter 7, meaning that sufficient steel reinforcement is available to prevent brittle failure at first cracking, even in the absence of the FRP EBR. Finally, it can be noted that increased ductility can be obtained by means of confinement (Chapter 6).

If the design of the strengthened flexural or tensile member is governed by e.g. the SLS, the amount of FRP provided to the structure may be considerably higher than what is needed for the ULS. In this case, it may be difficult to fulfil the ductility condition while yet high safety factors between the acting (S) and the resisting (R) design load in ULS are obtained (hence also a high safety factor between the service load and the resisting design load). In the case $R \geq \boxed{1.2}S$, the ductility condition should no longer be fulfilled.

4 Flexural strengthening

4.1 General

Reinforced concrete elements, such as beams and columns, may be strengthened in flexure through the use of FRP composites epoxy-bonded to their tension zones, with the direction of fibres parallel to that of high tensile stresses (member axis). The concept is illustrated in Fig. 4-1, which also shows a practical application. The analysis for the ultimate limit state in flexure for such elements may follow well-established procedures for reinforced concrete structures, provided that: (a) the contribution of external FRP reinforcement is taken into account properly; and (b) special consideration is given to the issue of bond between the concrete and the FRP.

In the following reference is made to reinforced concrete members strengthened with externally bonded FRP tensile reinforcement. In Section 4.8 reference is also made to prestressed concrete, EBR in compression and prestressed FRP EBR.

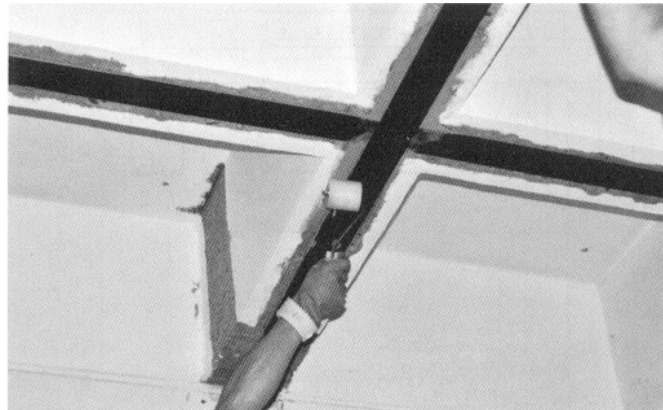

Fig. 4-1: Flexural strengthening of RC beams with CFRP strips.

Idealized stress-strain curves for concrete, FRP and steel were presented in Fig. 3-1. These curves, along with the assumption that the slip at the concrete-FRP interface may be ignored (an assumption which is justified for most structural adhesives applied at thicknesses in the order of 1.0-1.5 mm, in which case viscoelastic phenomena, such as axial and interlaminar shear creep as well as relaxation, are negligible), form the basis for the ultimate strength limit state analysis of concrete elements strengthened in flexure. Central to the analysis of these elements is the identification of all the possible *failure modes*. These are described below, following a brief presentation of the effect of initial load acting on the members at the time of strengthening.

4.2 Initial situation

The effect of the initial load prior to strengthening should be considered in the calculation of the strengthened member. Based on the theory of elasticity and with M_0 the service moment (no load safety factors are applied) acting on the critical RC section during strengthening, the strain distribution of the member can be evaluated. As M_0 is typically larger than the cracking moment M_{cr} , the calculation is based on a cracked section (Fig. 4-2).

If M_o is smaller than M_{cr} , its influence on the calculation of the strengthened member may easily be neglected.

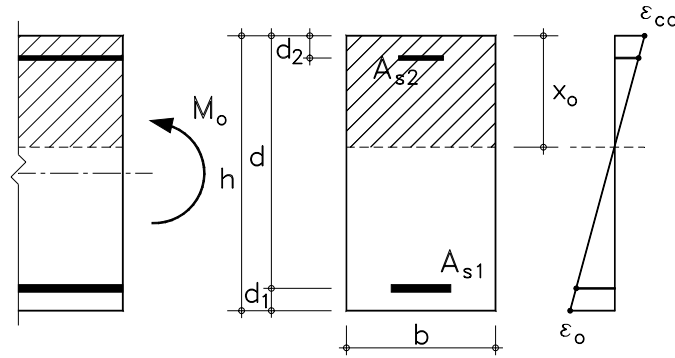

Fig. 4-2: Initial situation.

Based on the transformed cracked section, the neutral axis depth x_o can be solved from:

$$\frac{1}{2}bx_o^2 + (\alpha_s - 1)A_{s2}(x_o - d_2) = \alpha_s A_{s1}(d - x_o) \quad (4-1)$$

where $\alpha_s = E_s/E_c$. The concrete strain ϵ_{co} at the top fibre can be expressed as:

$$\epsilon_{co} = \frac{M_o x_o}{E_c I_{o2}} \quad (4-2)$$

where I_{o2} is the moment of inertia of the transformed cracked section:

$$I_{o2} = \frac{bx_o^3}{3} + (\alpha_s - 1)A_{s2}(x_o - d_2)^2 + \alpha_s A_{s1}(d - x_o)^2 \quad (4-3)$$

Based on strain compatibility, the concrete strain ϵ_o at the extreme tension fibre can be derived as:

$$\epsilon_o = \epsilon_{co} \frac{h - x_o}{x_o} \quad (4-4)$$

This strain equals the initial axial strain at the level of the FRP EBR, needed for the evaluation of the strengthened member.

4.3 Failure modes – ultimate limit states

The failure modes of a reinforced concrete element strengthened in flexure with externally bonded FRP reinforcement may be divided into two classes: (a) those where full composite action of concrete and FRP is maintained until the concrete reaches crushing in compression or the FRP fails in tension (such failure modes may also be characterized as “classical”) and (b) those where composite action is lost prior to class (a) failure, e.g. due to peeling-off of the FRP. A brief description of each failure mode is given below:

4.3.1 Full composite action

- Steel yielding followed by concrete crushing

The flexural strength may be reached with yielding of the tensile steel reinforcement followed by crushing of the concrete in the compression zone, whereas the FRP is intact.

- Steel yielding followed by FRP fracture

For relatively low ratios of both steel and FRP, flexural failure may occur with yielding of the tensile steel reinforcement followed by tensile fracture of the FRP.

- Concrete crushing

For relatively high reinforcement ratios, failure of the RC element may be caused by compressive crushing of the concrete before the steel yields. This mode is brittle and certainly undesirable. The FRP is in this case of little purpose, and means of increasing the compressive capacity of the concrete should be considered (e.g. confinement). Detailed treatment of the above three failure modes may be found in Triantafillou and Plevris (1992) and Matthys (2000).

4.3.2 Loss of composite action

4.3.2.1 Debonding and bond failure modes

Bond is necessary to transfer forces from the concrete into the FRP, hence *bond failure modes* have to be taken into account properly. Bond failure in the case of EBR implies the complete loss of composite action between the concrete and the FRP reinforcement, and occurs at the interface between the EBR and the concrete substrate. On the other hand, localised *debonding*, means a local failure in the bond zone between concrete and EBR. In this case the reduction in bond strength between concrete and FRP reinforcement is limited to a small area, e.g. a loss in bond length of 2 mm next to a crack in a flexural member. Therefore localised debonding is not in itself a failure mode which will definitely cause a loss of the load carrying capacity of a member with EBR.

When localised debonding propagates, and composite action is lost in such a way that the FRP reinforcement is not able to take loads anymore, this failure is called *peeling-off*. If no stress redistribution from the externally bonded FRP reinforcement to the embedded reinforcement is possible, peeling-off will be a sudden and brittle failure.

Bond failure may occur at different interfaces between the concrete and the FRP reinforcement, as described below (see also Fig. 4-3).

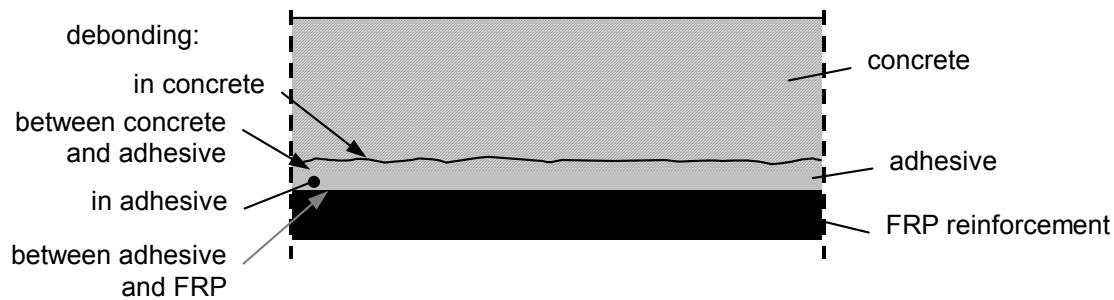

Fig. 4-3: Different interfaces for bond failure.

- Debonding in the concrete near the surface or along a weakened layer, e.g. along the line of the embedded steel reinforcement (Fig. 4-4)

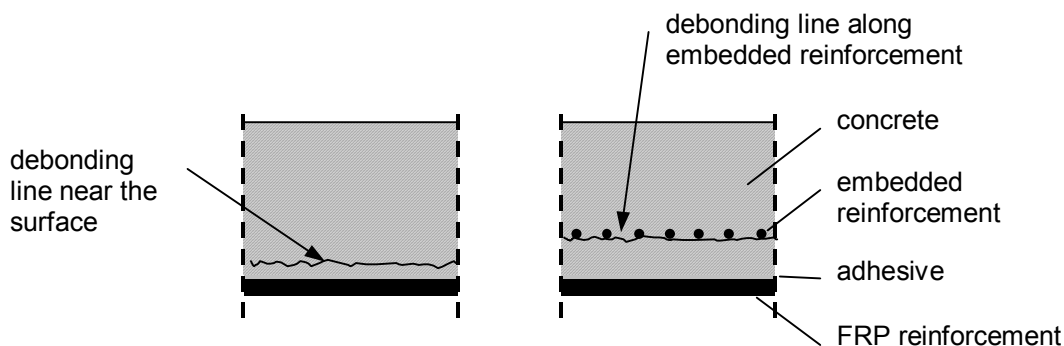

Fig. 4-4: Different debonding lines in the concrete.

- Debonding in the adhesive (cohesion failure)

As the tensile and shear strength of the adhesive (epoxy resin) is usually higher than the tensile and shear strength of concrete, failure will normally occur in the concrete. In this case a thin layer of concrete (a few millimeters thick) will remain on the FRP reinforcement. Debonding may occur through the adhesive only if its strength drops below that of concrete (e.g. at high temperatures or when the strength of concrete is unusually high).

- Debonding at the interfaces between concrete and adhesive or adhesive and FRP (adhesion failure)

Bond failures in the interfaces between concrete and adhesive or adhesive and FRP will only occur if there is insufficient surface preparation during the FRP application process, because the cohesion strength of epoxy resins is lower than the adhesion strength.

- Debonding inside the FRP (interlaminar shear failure)

Because the FRP is a composite material itself, debonding may also occur inside the FRP between fibres and resin. This failure mechanism, as may be explained by fracture mechanics, will occur once crack propagation in the FRP is energetically more convenient than in the concrete. This might be the case with high strength concretes. Nevertheless, interlaminar failure is a secondary failure mode, that occurs after the bond fracture has

initiated in the concrete, and, hence, usually does not determine bond strength. No further elaboration will be given here.

4.3.2.2 Bond behaviour

The behaviour of the bond between externally bonded FRP and concrete can be analysed in bond tests, such as the one illustrated in a simplified form in Fig. 4-5.

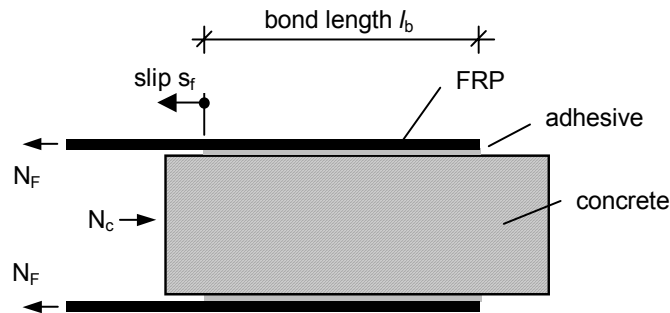

Fig. 4-5: Simplified bond test (e.g. Zilch et al. 1998, Bizindavyi and Neale 1999).

A typical distribution of the shear stresses along the bond length for different load levels is shown in Fig. 4-6 for a CFRP plate 50 mm wide and 1.2 mm thick, with a bond length of 250 mm. For low load levels the shear stresses are mainly concentrated near the loaded end, but as the load increases they move towards the unloaded end. Unlike the simplified bond test, the exact distribution in case of a strengthened flexural member is influenced as well by the normal stresses perpendicular to the bond area, which are caused by bending effects.

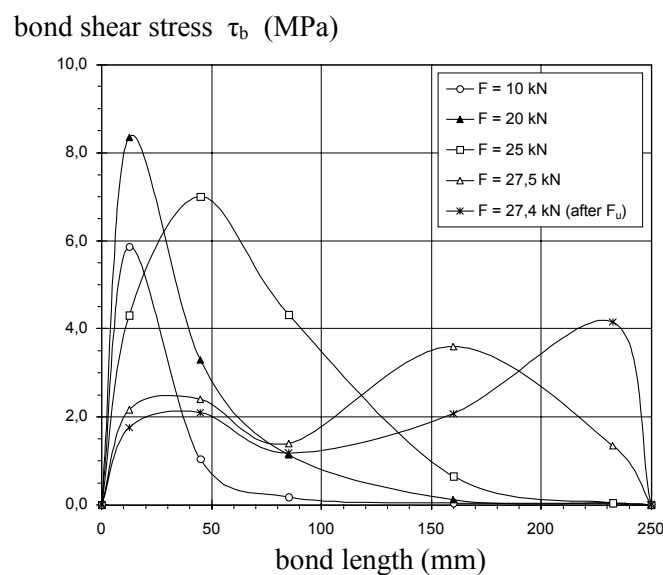

Fig. 4-6: Distribution of shear stresses along the bond length (Zilch et al. 1998).

The behaviour of the bond between concrete and reinforcement can be characterized by the shear-slip relation. This relates the shear stress which is locally transferred between concrete and reinforcement to the displacement, that is the *slip*, between the two materials.

Shear-slip relations for different types of reinforcement are shown in Fig. 4-7. The bond of EBR is very stiff compared to the bond of embedded deformed steel bars, but the total load capacity of the bond is much lower (the area under the curves in Fig. 4-7 indicates the energy, which can be borne in the reinforcement by bond). The difference in bond characteristics influences the division of the tensile force into the embedded and the externally bonded FRP reinforcement.

For design purposes, the shear-slip behaviour may be simplified and modelled according to various degrees of complexity. As an example the model of Holzenkämpfer (1994) is shown in Fig. 4-8, for a concrete tensile strength of $f_{ctm} = 2$ MPa.

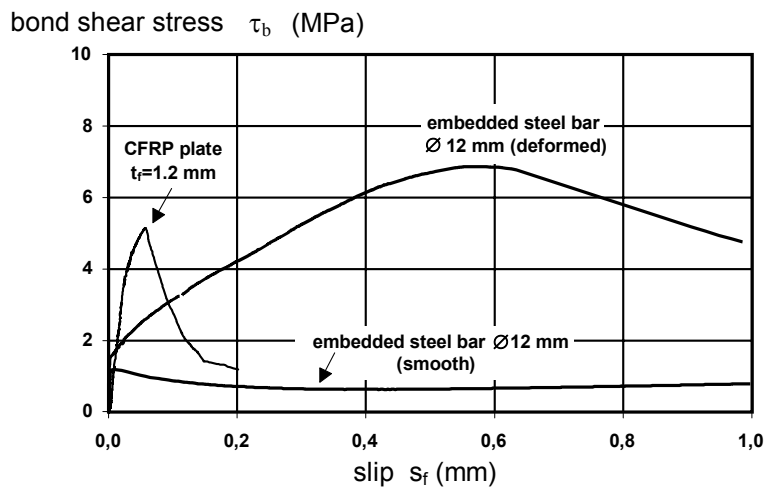

Fig. 4-7: Shear stress - slip relations for different types of reinforcement (Zilch et al. 1998).

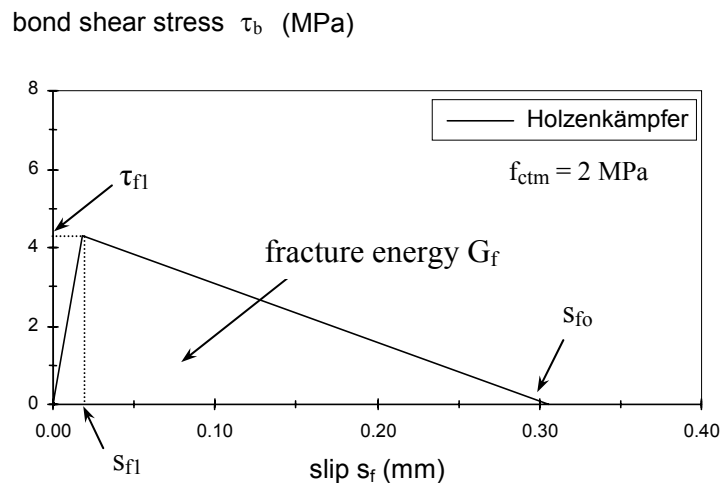

Fig. 4-8: Models for the shear stress - slip relations of EBR (Holzenkämpfer 1994).

Bond models such as that described above may be used for calculating anchoring forces, crack formations etc.

4.3.2.3 Bond behaviour of RC members strengthened with FRP

Most failures observed in tests of RC flexural members with EBR are caused by peeling-off of the EBR element. As discussed above, the weakest point in the bond between the EBR and the concrete is in the concrete layer near the surface. Hence in the following we shall concentrate on bond failure modes related to the concrete surface. Depending on the starting point of the debonding process, the following failure modes can be identified (Fig. 4-9):

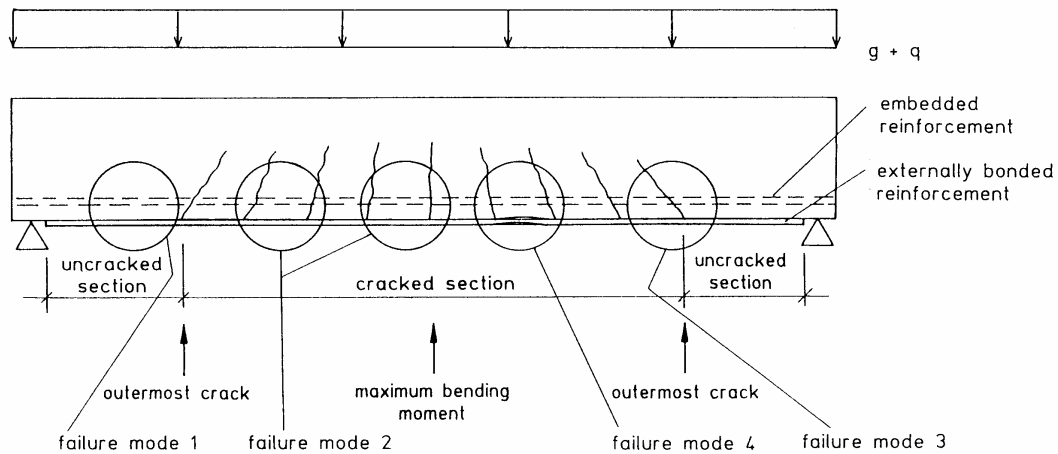

Fig. 4-9: Bond failure modes of a concrete member with EBR (Blaschko et al. 1998).

- Mode 1: peeling-off in an uncracked anchorage zone

The FRP may peel-off in the anchorage zone as a result of bond shear fracture through the concrete.

- Mode 2: peeling-off caused at flexural cracks

Flexural (vertical) cracks in the concrete may propagate horizontally and thus cause peeling-off of the FRP in regions far from the anchorage.

- Mode 3: peeling-off caused at shear cracks

Shear cracking in the concrete generally results in both horizontal and vertical opening, which may lead to FRP peeling-off. However, in elements with sufficient internal (and external) shear reinforcement (as well as in slabs) the effect of vertical crack opening on peeling-off is negligible

- Mode 4: peeling-off caused by the unevenness of the concrete surface

The unevenness or roughness of the concrete surface may result in localized debonding of the FRP, which may propagate and cause peeling-off.

4.3.2.4 FRP end shear failure

Tests by several investigators, e.g. (Oehlers and Moran 1990, Jansze 1997), have indicated that when externally bonded plates stop at a certain distance from the supports (as is typically

the case in strengthening applications) a nearly vertical crack might initiate at the plate end (plate end crack) and then grow as an inclined shear crack (Fig. 4-10 left). However, by virtue of internal stirrups, the shear crack may be arrested and the bonded-on plate separated from the concrete at the level of the longitudinal reinforcement in the form of spalling (Fig. 4-10 right). The latter failure mode is also called concrete rip-off. Both failure mechanisms will be activated when the maximum shear stress near the plate end reaches a critical value.

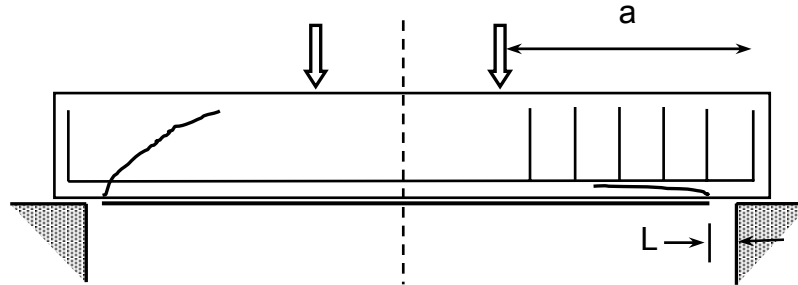

Fig. 4-10: FRP plate-end shear failure.

A more detail treatment of the failure mechanisms described above is given in the following section.

4.4 Analysis of ULS

4.4.1 Full composite action

4.4.1.1 Steel yielding followed by concrete crushing

According to the steel yielding / concrete crushing failure mode, which is the most desirable, failure of the critical cross section occurs by yielding of the tensile steel reinforcement followed by crushing of concrete, while the FRP is intact. The design bending moment of the strengthened cross section is calculated based on principles of RC design (see Fig. 4-11). First, the neutral axis depth, x , is calculated from strain compatibility and internal force equilibrium, and then the design moment is obtained by moment equilibrium. The analysis should take into account that the RC element may not be fully unloaded when strengthening takes place, and hence an initial strain ε_o in the extreme tensile fibre (see Fig. 4-11) should be considered.

The design bending moment capacity may be calculated based on the following:

Calculation of neutral axis depth, x :

$$0.85\psi f_{cd} b x + A_{s2} E_s \varepsilon_{s2} = A_{s1} f_{yd} + A_f E_f \varepsilon_f \quad (4-5)$$

where $\psi = 0.8$ and

$$\varepsilon_{s2} = \varepsilon_{cu} \frac{x - d_2}{x} \quad (E_s \varepsilon_{s2} \text{ not to exceed } f_{yd}) \quad (4-6)$$

$$\varepsilon_f = \varepsilon_{cu} \frac{h - x}{x} - \varepsilon_o \quad (4-7)$$

Design bending moment capacity:

$$M_{Rd} = A_{s1}f_{yd}(d - \delta_G x) + A_f E_f \varepsilon_f (h - \delta_G x) + A_{s2} E_s \varepsilon_{s2} (\delta_G x - d_2) \quad (4-8)$$

where $\delta_G = 0.4$.

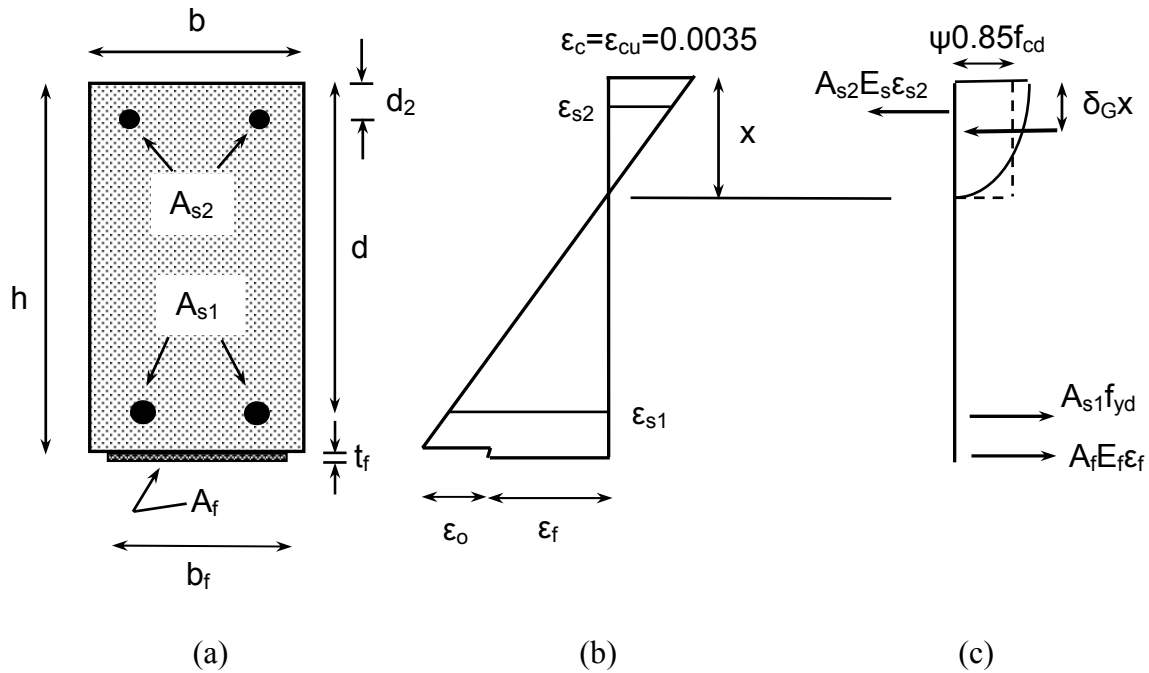

Fig. 4-11: Analysis of cross section for the ultimate limit state in bending: (a) geometry, (b) strain distribution and (c) stress distribution.

For the equations given above to be valid, the following assumptions should be checked: (a) yielding of tensile steel reinforcement and (b) straining of the FRP is limited to the ultimate strain, ε_{fud} :

$$\varepsilon_{s1} = \varepsilon_{cu} \frac{d-x}{x} \geq \frac{f_{yd}}{E_s} \quad (4-9)$$

$$\varepsilon_f = \varepsilon_{cu} \frac{h-x}{x} - \varepsilon_o \leq \varepsilon_{fud} \quad (4-10)$$

4.4.1.2 Steel yielding followed by FRP fracture

The failure mode involving steel yielding / FRP fracture is theoretically possible. However, it is quite likely that premature FRP debonding will precede FRP fracture and hence this mechanism will not be activated. For the sake of completeness we may state here that the analysis for this mechanism may be done along the lines of the previous section.

Equations (4-5) – (4-8) still apply, with the following modifications: ε_{cu} is replaced by ε_c ; ε_f is replaced by ε_{fid} ; and ψ , δ_G are provided by the following expressions:

$$\psi = \begin{cases} 1000\varepsilon_c \left(0.5 - \frac{1000}{12} \varepsilon_c \right) & \text{for } \varepsilon_c \leq 0.002 \\ 1 - \frac{2}{3000\varepsilon_c} & \text{for } 0.002 \leq \varepsilon_c \leq 0.0035 \end{cases} \quad (4-11)$$

$$\delta_G = \begin{cases} \frac{8 - 1000\varepsilon_c}{4(6 - 1000\varepsilon_c)} & \text{for } \varepsilon_c \leq 0.002 \\ \frac{1000\varepsilon_c(3000\varepsilon_c - 4) + 2}{2000\varepsilon_c(3000\varepsilon_c - 2)} & \text{for } 0.002 \leq \varepsilon_c \leq 0.0035 \end{cases} \quad (4-12)$$

4.4.2 Loss of composite action

4.4.2.1 Peeling-off caused at shear cracks

Shear cracks in concrete elements are inclined, and are associated with both horizontal, w , and vertical, v , opening displacements, primarily due to the aggregate interlock and dowel action mechanisms. In analogy to what was described in the Section 4.3.2.3, the horizontal crack opening displacement may result in peeling-off. But the vertical crack opening displacement may cause peeling-off too, as it induces direct tension in the concrete layer between the FRP and the embedded longitudinal steel reinforcement (Fig. 4-12). Whether peeling-off will initiate or not in this case (for a given horizontal crack opening displacement) depends on a number of parameters, including the following (Triantafillou and Plevris 1992): (a) the vertical crack opening displacement; (b) the flexural and shear rigidity of the FRP; and (c) the tensile strength of concrete.

Peeling-off caused at shear cracks has not been quantified in proper detail by the research community yet (an appropriate bond model is yet to be developed). The model of Deuring (1993) is probably the most comprehensive one as of to date, but is rather complicated to apply. In a relatively recent study Blaschko (1997) proposed that peeling-off at shear cracks may be prevented by limiting the acting shear force to the shear resistance V_{Rd1} of RC members without shear reinforcement (Eurocode 2 approach) with the following modification for the characteristic shear strength of concrete τ_{Rk} and the equivalent longitudinal reinforcement ratio ρ_{eq} :

$$\tau_{Rk} = 0.15f_{ck}^{1/3} \quad (4-13)$$

$$\rho_{eq} = \frac{A_s + A_f \frac{E_f}{E_s}}{bd} \quad (4-14)$$

In case the design shear capacity falls below the required, an appropriate means of shear strengthening should be provided.

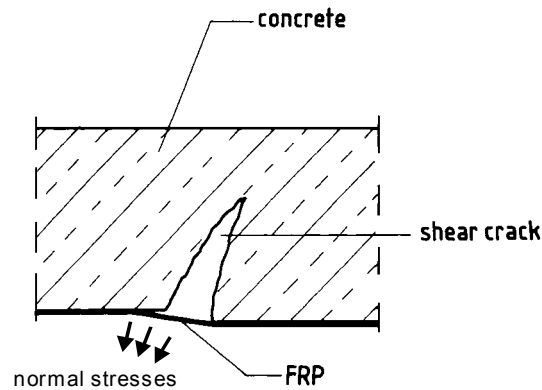

Fig. 4-12: Peeling-off caused at shear cracks.

Based on experimental results (concrete grades C25/30 to C30/37, CFRP prefab on wet lay-up type), Matthys (2000) has derived a shear resistance $V_{Rp} = \tau_{Rp}bd$, with a characteristic value for the shear strength $\tau_{Rk} = 0.38 + 151\rho_{eq}$ (MPa).

4.4.2.2 Peeling-off at the end anchorage and at flexural cracks

Treatment of peeling-off at the end anchorage and at flexural cracks may be done according to various approaches, which are described briefly in the following. Detailed treatment of these approaches is presented in the Appendix of this chapter.

- Verification of end anchorage, strain limitation in the FRP

This approach involves two independent steps: first, the end anchorage should be verified based on the shear stress – slip constitutive law at the FRP-concrete interface. Then a strain limitation should be applied on the FRP to ensure that bond failure far from the anchorage will be prevented. Notably, this procedure has been followed in a number of draft design guidelines so far, mainly due to its simplicity. However, it represents a crude simplification of the real behaviour, as the FRP strain corresponding to bond failure is not a fixed value but it depends on a series of parameters, including the moment-shear relation, the strain in the internal steel and the distribution of cracks.

- Verification according to the envelope line of tensile stresses in the FRP

In this approach peeling-off is treated in a unified way both at the end anchorage and at any point along the FRP-concrete interface based on the interface shear stress – slip law and the envelope line of tensile stresses in the FRP (Niedermeier 2000). The main advantage of this approach is that peeling-off at the end and at flexural cracks is treated with the same model, whereas the main disadvantage is its complexity, which makes it difficult to apply as a practical engineering model.

- Verification of end anchorage and of force transfer at the FRP/concrete interface

According to the third approach (Matthys 2000), two independent steps should be followed (as in the first one). In the first, the end anchorage should be verified based on the shear stress – slip constitutive law at the FRP-concrete interface. And in the second it should

be verified that the shear stress along the interface, calculated based on simplified equilibrium conditions, is kept below a critical value (the shear strength of concrete). One disadvantage of this approach is the treatment of the same – in principle - phenomenon (peeling-off at the FRP end and far from it) with different models and another one is that it is based on a stress distribution for a homogeneous, uncracked beam. However, one major advantage is the simplicity of application in practical problems.

4.4.2.3 End shear failure

Jansze (1997) employed the *fictitious shear span* concept, illustrated in Fig. 4-13, to compute the shear resistance of plated beams along the lines of the Model Code (CEB 1993).

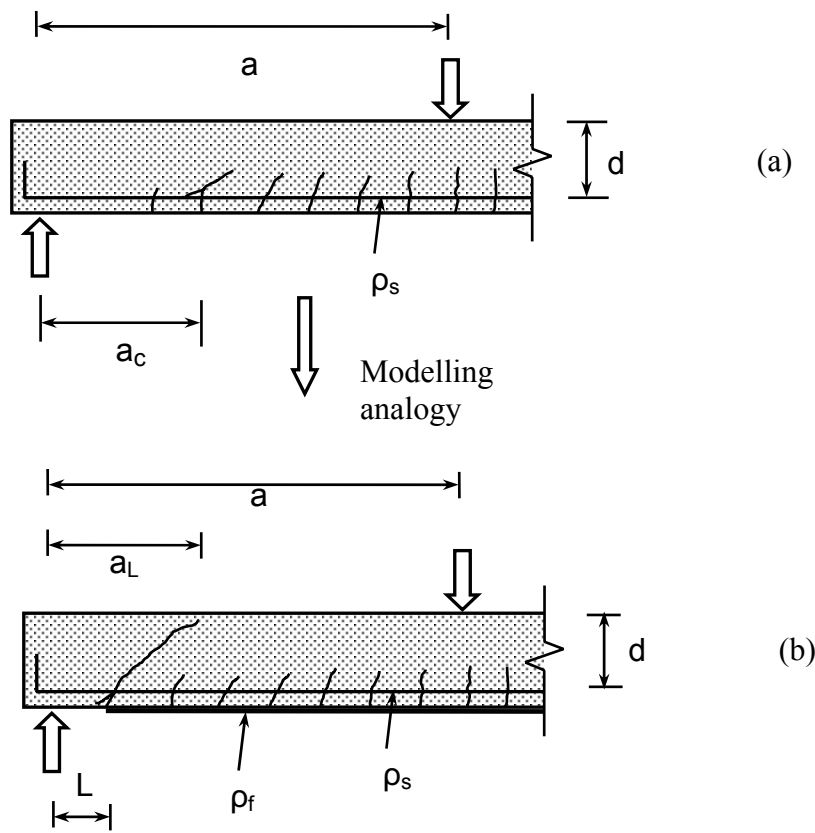

Fig. 4-13: (a) Concept of fictitious shear span and (b) modelling analogy for the analysis of FRP-end shear failure.

The resulting equations are summarized below:

$$V_{Sd} \leq V_{Rd} = \tau_{Rd} b d \quad (4-15)$$

$$\tau_{Rd} = 0.15 \sqrt[3]{3 \frac{d}{a_L} \left(1 + \sqrt{\frac{200}{d}} \right) \sqrt[3]{100 \rho_s f_{ck}}} \quad (4-16)$$

$$a_L = \sqrt[4]{\frac{(1 - \sqrt{\rho_s})^2}{\rho_s}} d L^3 \quad (4-17)$$

$$a > L+d, \quad a_L < a \quad (4-18)$$

In the above equations L (in mm) is the distance of the FRP end from the support, a (in mm) is the shear span and $\rho_s = A_{s1}/bd$.

The fictitious shear span concept provides a simplified engineering approach for the FRP end shear failure (including concrete rip-off failure). The reader should note that other models have been developed too (e.g. Täljsten 1994 and 1997, Malek et al. 1998), based on the analytical calculation of shear and normal stresses at the FRP end. However, such models are much more complicated to use, and their description is not given in this Bulletin.

4.4.2.4 Peeling-off caused by the unevenness of the concrete surface

Debonding of the FRP due to possible unevenness of the concrete surface (Fig. 4-14) is another failure mechanism that has not been studied thoroughly. Experimental evidence suggests that this mechanism may be avoided by adopting certain practical execution rules and limitations on concrete surface roughness (see Chapter 9). Most of these limitations refer to a maximum concrete roughness over a given length, and depend on FRP type and dimensions (e.g. thickness). Specific details should be looked for in specifications normally provided by suppliers of FRP strengthening systems.

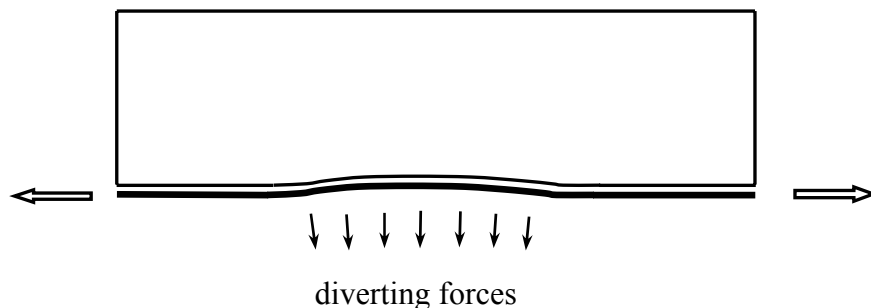

Fig. 4-14: Peeling-off caused by unevenness of concrete surface.

4.5 Ductility requirements

Ductility may be quantified in terms of the curvature ductility index (curvature at failure divided by curvature at yield), which can be derived from moment-curvature diagrams (e.g. such as those in Triantafillou and Plevris 1992). As sudden failures with no or very little warning are undesirable, the ductility index should exceed a certain value as suggested in Chapter 3.

4.6 Serviceability limit state

4.6.1 Basis of calculation

Calculations to verify the serviceability limit state may be performed according to a linear elastic analysis. Reference will be made to both uncracked (state 1) and cracked sections

(state 2). Whereas the neutral axis depth of RC members, according to a linear elastic calculation, is independent from the acting moment, this is no longer the case for a strengthened section as a result of the initial strains before strengthening. Assuming linear elastic material behaviour and that the concrete does not sustain tension, the cracked section analysis can be based on Fig. 4-15 (Matthys 2000).

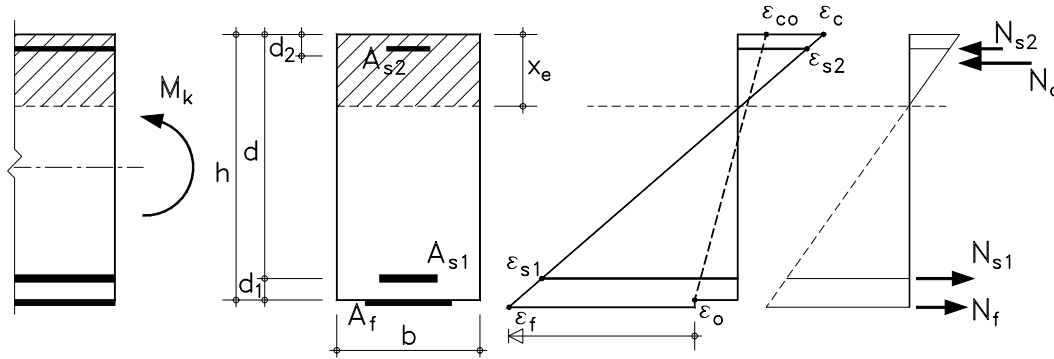

Fig. 4-15: Linear elastic analysis of cracked section.

From the equilibrium of forces and strain compatibility, the depth of the neutral axis x_e is obtained from the following:

$$\frac{1}{2}bx_e^2 + (\alpha_s - 1)A_{s2}(x_e - d_2) = \alpha_s A_{s1}(d - x_e) + \alpha_f A_f \left[h - \left(1 + \frac{\varepsilon_o}{\varepsilon_c} \right) x_e \right] \quad (4-19)$$

where $\alpha_f = E_f/E_c$. For low values of the initial strain ε_o , the term $(1 + \varepsilon_o/\varepsilon_c)$ equals about 1, so that eq. (4-19) can be solved directly for x_e . For high values of ε_o compared to the acting concrete strain ε_c at the extreme compression fibre, the neutral axis depth x_e should be solved from eq. (4-19) - (4-20):

$$E_c \varepsilon_c = \frac{M_k}{\frac{1}{2}bx_e \left(h - \frac{x_e}{3} \right) + (\alpha_s - 1)A_{s2} \frac{(x_e - d_2)}{x_e} (h - d_2) - \alpha_s A_{s1} \frac{d - x_e}{x_e} (h - d)} \quad (4-20)$$

Neglecting the steel reinforcement in compression ($A_{s2} = 0$) and assuming $h/d \approx 1.1$ (mean effective depth of the steel and FRP reinforcement $\approx 1.05d$), eq. (4-20) can be written as:

$$E_c \varepsilon_c = \frac{M_k}{\frac{1}{2}bx_e \left(1.05d - \frac{x_e}{3} \right)} \quad (4-21)$$

or, based on the equations in Section 4.2,

$$\frac{\varepsilon_o}{\varepsilon_c} \approx \frac{M_o}{M_k} \frac{x_e}{x_o} \quad (4-22)$$

where M_o is the service moment prior to strengthening and x_o , the corresponding neutral axis depth, is calculated from eq. (4-1). The moment of inertia of the cracked section is given by:

$$I_2 = \frac{bx_e^3}{3} + (\alpha_s - 1)A_{s2}(x_e - d_2)^2 + \alpha_s A_{s1}(d - x_e)^2 + \alpha_f A_f (h - x_e)^2 \quad (4-23)$$

and depends, similar as for x_e , on the acting moment M_k .

The uncracked section analysis can be performed in a similar way as the cracked section analysis. However, as M_o is typically higher than the cracking moment M_{cr} and as the influence of the FRP reinforcement is limited anyway, the geometrical characteristics of the uncracked section before strengthening apply. Neglecting also the contribution of the steel reinforcement, the moment of inertia (for rectangular beams) can be approximated as:

$$I_1 \approx \frac{bh^3}{12} \quad (4-24)$$

and the cracking moment, for rectangular beams, M_{cr} as:

$$M_{cr} \approx f_{ctm} \frac{bh^2}{6} \quad (4-25)$$

4.6.2 Stress limitation

Under service load conditions it is required to limit stresses in the concrete, steel and FRP to prevent damage or excessive creep of the concrete, steel yielding and excessive creep or creep rupture of the FRP. If external tensile reinforcement is added and as the compression force equals the total tensile force, a significant change in the state of concrete stress may be expected. To prevent excessive compression, producing longitudinal cracks and irreversible strains, the following limitations for the concrete compressive stress apply (Eurocode 2):

$$\sigma_c \leq 0.60f_{ck} \quad \text{under the rare load combination} \quad (4-26a)$$

$$\sigma_c \leq 0.45f_{ck} \quad \text{under the quasi-permanent load combination} \quad (4-26b)$$

where $\sigma_c = E_c \varepsilon_c$ is obtained from eq. (4-20).

To prevent yielding of the steel at service load, Eurocode 2 specifies:

$$\sigma_s = E_s \varepsilon_c \frac{d - x_e}{x_e} \leq 0.80f_{yk} \quad \text{under the rare load combination} \quad (4-27)$$

In a similar way, the FRP stress under service load should be limited as:

$$\sigma_f = E_f \left(\varepsilon_c \frac{h - x_e}{x_e} - \varepsilon_o \right) \leq \eta f_{fk} \quad \text{under the quasi-permanent load combination} \quad (4-28)$$

where $\eta < 1$ is the FRP stress limitation coefficient. This coefficient depends on the type of FRP and should be obtained through experiments. Based on creep rupture tests (e.g. Yamaguchi et al. 1998), indicative values of $\eta = 0.8, 0.5$ and 0.3 may be suggested for CFRP, AFRP and GFRP, respectively. Note that as the design is often governed by the SLS, relative low FRP strains at service load may be expected, so that FRP creep rupture is typically not of concern.

4.6.3 Verification of deflections

As already a small amount of external FRP significantly increases the failure load, small cross-sectional areas A_f are needed for the ULS. As also the modulus of elasticity of FRP can be relatively low, this results in a low axial stiffness $E_f A_f$. This stiffness is often insufficient to limit curvatures and deflections of the strengthened beam under service load, and may need to be increased to fulfill the SLS.

In terms of methods for the prediction of deflections, quite high accuracy is obtained for calculations based on numerical integration of the curvature, which is determined taking into account tension stiffening and a non-linear analysis of the cracked section. A more simplified calculation can be performed according to the so-called CEB bilinear method (see CEB 1993), which gives reasonably accurate predictions at the SLS. According to this method, the mean deflection, a , is calculated from:

$$a = a_1(1 - \zeta_b) + a_2\zeta_b \quad (4-29)$$

where a_1 and a_2 are the deflections in the uncracked and the fully cracked state, respectively, and ζ_b is a distribution (tension stiffening) coefficient:

$$\begin{aligned} \zeta_b &= 0 & M_k < M_{cr} \\ \zeta_b &= 1 - \beta_1 \beta_2 \left(\frac{M_{cr}}{M_k} \right)^{n/2} & M_k > M_{cr} \end{aligned} \quad (4-30)$$

where β_1 is a coefficient taking into account the bond characteristics of the reinforcement and β_2 is a coefficient taking into account the loading type. According to CEB (1993), the power n equals 2. For high strength concrete more accuracy is obtained with n equal to 3 (Lambotte and Taerwe 1990). Although the bond behaviour of FRP differs from that of steel, a good agreement between experimental and analytical results is reported in Matthys (2000), if β_1 and β_2 are taken as specified in EC2 ($\beta_1 = 0.5$ and 1 for smooth and deformed steel, respectively; $\beta_2 = 0.5$ and 1 for long-term and short-term loading, respectively). The deflection in the uncracked state, a_1 , and in the fully cracked state, a_2 , can be calculated by classical elasticity analysis, referring to a flexural stiffness in the uncracked state $E_c I_1$ and in the fully cracked state $E_c I_2$, respectively. Taking into account the moment M_0 at which the FRP is applied, this yields:

$$a_1 = k_M \ell^2 \frac{M_k}{E_c I_1} \quad (4-31)$$

$$a_2 = k_M \ell^2 \left(\frac{M_o}{E_c I_{o2}} + \frac{M_k - M_o}{E_c I_2} \right) \quad M_k > M_o \quad (4-32)$$

where k_M is a coefficient depending on the loading type and I_{o2} is the moment of inertia in the cracked state before strengthening.

4.6.4 Verification of crack widths

To protect the internal steel and to guarantee functionality of the member, crack widths should be limited. For RC beams strengthened with EBR, new cracks will appear in between existing cracks. Hence, denser cracking and smaller crack widths are obtained, which often makes the verification of crack widths not necessary.

Assuming stabilized cracking, the characteristic value of the crack width is calculated according to Eurocode 2 as:

$$w_k = \beta s_{rm} \varepsilon_{rm,r} = \beta s_{rm} \zeta \varepsilon_2 \quad (4-33)$$

where $\beta = 1.7$ is a coefficient which relates the mean and characteristic value of the crack width, s_{rm} is the mean crack spacing, $\varepsilon_{rm,r}$ is the mean strain of the steel reinforcement with respect to the surrounding concrete, ζ is a tension stiffening coefficient similar to that given in eq. (4-30):

$$\begin{aligned} \zeta &= 0 & M_k < M_{cr} \\ \zeta &= 1 - \beta_1 \beta_2 \left(\frac{M_{cr}}{M_k} \right)^n & M_k > M_{cr} \end{aligned} \quad (4-34)$$

and ε_2 is the reinforcement strain in the fully cracked state. Assuming $\varepsilon_2 \approx \varepsilon_{s1} \approx \varepsilon_f + \varepsilon_o$ and with $N_{rk} = N_{s1} + N_f$, ε_2 is given as:

$$\varepsilon_2 = \frac{N_{rk} + E_f A_f \varepsilon_o}{E_s A_s + E_f A_f} \quad (4-35)$$

with $N_{rk} = M_k/z_e$ and z_e the lever arm between the total tensile force ($N_{s1} + N_f$) and the compression force ($N_c + N_{s2}$).

The mean crack spacing, s_{rm} , taking into account the effect of both the internal and the external reinforcement, can be calculated as (Rostásy et al. 1996):

$$s_{rm} = \frac{2f_{ctm} A_{c,eff}}{\tau_{sm} u_s} \frac{E_s A_s}{E_s A_s + \zeta_b E_f A_f} = \frac{2f_{ctm} A_{c,eff}}{\tau_{fm} u_f} \frac{\zeta_b E_f A_f}{E_s A_s + \zeta_b E_f A_f} \quad (4-36)$$

where $A_{c,eff}$ is the effective area in tension taken as the lesser of $2.5(h - d)b$ and $(h - x)b/3$ (Eurocode 2), $\tau_{sm} = 1.8f_{ctm}$ (CEB 1993) and $\tau_{fm} = 1.25f_{ctm}$ (Holzenkampfer 1994) is the mean bond stress of the steel and the FRP, u_s and u_f is the bond perimeter of the steel and FRP reinforcement and ζ_b is a bond parameter given as:

$$\xi_b = \frac{\tau_{fm} E_s A_s u_f}{\tau_{sm} E_f A_f u_s} = \frac{\tau_{fm} E_s d_s}{\tau_{sm} E_f 4t_f} \quad (4-37)$$

where d_s is the (mean) diameter of the steel bars and t_f is thickness of the FRP.

Neglecting the tension stiffening effect ($\zeta = 1$) and assuming $\varepsilon_o \approx 0$, the crack width is derived from eq. (4-33) – (4-37) as:

$$w_k = 2.1 \rho_{c,eff} \frac{M_k}{E_s d \rho_{eq}} \frac{1}{(u_s + 0.694 u_f)} \quad (4-38)$$

where $\rho_{c,eff} = A_{c,eff}/bd$ is the ratio of the effective area in tension and ρ_{eq} is the equivalent reinforcement ratio. Specifying $w_k \leq 0.3$ mm (EC2), the following condition is obtained for the FRP bond width $u_f = b_f$ (b_f total width of the bonded FRP):

$$u_f \geq 10.1 \rho_{c,eff} \frac{M_k}{E_s d \rho_{eq}} - 1.44 u_s \quad (4-39)$$

Eq. (4-39) expresses that sufficient bond area should be provided to bridge the cracks in such a way that the crack width is limited under service load (for a constant value of ρ_f and hence ρ_{eq} , crack widths will be smaller for FRP with large width and small thickness). For very deep beams it may appear that the required bond width u_f is larger than the available width b of the beam. In this case ρ_f should be increased by considering also a larger FRP thickness.

4.6.5 Verification of bond interface cracking

Stress concentrations are especially obtained at the FRP end and at the location of cracks. At service load, bond interface crack initiation at the FRP curtailment should be prevented as it may reduce the long-term integrity of the anchorage zone under e.g. cyclic loading and freeze/thaw action. To fulfill this requirement it should be verified (SLS, quasi-permanent load combination) that the maximum shear stress τ_{fl} at the FRP end, calculated according to a linear elastic analysis, is smaller than f_{ctk} . In the case that an extra anchorage is provided at the FRP end, this verification is no longer necessary. One approach to calculate τ_{fl} is that of Roberts (1989):

$$\tau_{fl} = \left[V_{x=0} + \left(\frac{G_a}{E_f t_f t_a} \right)^{1/2} M_{x=0} \right] \frac{t_f (h - x_e)}{I_c} \quad (4-40)$$

where G_a and t_a is the shear modulus and thickness, respectively, of the adhesive at the FRP-concrete interface; $V_{x=0}$ and $M_{x=0}$ is the shear force and bending moment acting on the section corresponding to the end of the FRP; and I_c is the moment of inertia of the transformed cracked section.

It may be argued that local debonding at the location of cracks can be allowed in ULS as long as no bond failure is obtained. However, this local debonding should be avoided at

service load to guarantee the long-term integrity of the bond interface. From Fig. 4-8 it follows that local debonding occurs if the slip is larger than s_{fo} :

$$s_{fo} = \frac{2G_F}{\tau_{fl}} \quad (4-41)$$

With $G_F = c_F f_{ctm}$, $\tau_{fl} = 1.8 f_{ctm}$ and $c_F = 0.202$ mm (Neubauer and Rostásy 1997), the ultimate slip s_{fo} equals 0.224 mm, which corresponds to a crack width $2s_{fo} = 0.45$ mm. As the characteristic value of the crack width under service load is limited to a maximum of 0.30 mm (mean crack width of 0.18 mm), it appears that **local debonding will not occur in the SLS**.

4.7 Summary of design procedure

The procedure for dimensioning FRP-strengthened RC elements in flexure may be summarized as follows:

- For the member before strengthening: determine the resisting design moment (ULS) and check the SLS. The latter is not needed directly, but it will provide valuable information with respect to the SLS of the strengthened member (most likely to govern the design).
- From the service moment M_o prior to strengthening determine the initial strain ε_o at the extreme tension fibre.
- Assume full composite action and from the design moment after strengthening determine the required FRP cross section to fulfill the ULS. Verify that sufficient ductility is obtained (Section 3.3).
- Calculate the deflections in the SLS. If the maximum allowable deflection is exceeded, determine the required FRP cross section to fulfill the deflection requirements.
- Calculate the stresses in the concrete, steel and FRP in the SLS. If allowable stresses are exceeded, determine the required FRP cross section to fulfill the stress limitation requirements.
- Verify that the provided FRP bond width is sufficient to control crack widths in the SLS. Increase the FRP width, if necessary, or, given a maximum width, increase the amount (thickness) of FRP. Bond interface cracking in the SLS is not of concern.
- Verify the resisting shear force at which bond failure due to shear cracks (vertical crack displacement) occurs (ULS). If this failure mode dominates, determine a new value of the FRP cross section.
- Verify that bond failure at the end anchorage and along the FRP (e.g. in regions where flexural cracking dominates) does not occur. If this is the case mechanical anchorage should be provided.
- Verify that FRP end shear failure is avoided. Provide shear strengthening at the ends if required.
- Verify the accidental situation.
- Verify the shear design resistance of the strengthened member (see next chapter). If needed shear strengthening should be provided.

4.8 Special cases

4.8.1 Pre-tensioned or post-tensioned concrete elements

In this section, general considerations are presented regarding the FRP-strengthening of prestressed elements. All issues involved are dealt with from a qualitative standpoint, the reason being that, so far, research in this field has only produced a few studies, both theoretical and experimental. These, being necessarily limited in scope and variety of cases, cannot offer conclusions of general validity and are a bit far from proposing commonly usable design rules (as a matter of fact, less than 10% of the bridges that have been FRP-strengthened so far are prestressed). Thus, this section proposes itself, instead of as a state-of-the-art, rather as an attempt to clarify all issues involved and to identify the most impellent research needs. In what follows, reference is made to the following prestressed members that might require FRP strengthening: bridge superstructures (girders, beams and decks) and slabs for prefabricated floors. The following does not cover strengthening of elements with either unbonded tendons, external tendons, or made from lightweight aggregate concrete.

4.8.1.1 Considerations on FRP-strengthening of prestressed concrete members

In designing an FRP-strengthening of a prestressed member, the conceptual implications due to the presence of long-term phenomena should be clearly understood, as opposed to the case of conventional reinforced concrete, where the effects of shrinkage and creep are easily dealt with.

Strengthening interventions usually take place when all long-term phenomena (creep, shrinkage, relaxation) have fully developed. Though this apparently favourable situation may seem to simplify the design procedure, it actually complicates the preliminary assessment phase of the existing conditions: the current state depends on all previous states, which therefore must be properly reconstructed. Thus, special care should be devoted to: construction sequence, with due consideration to all prestressing phases, correct description of long-term phenomena along with their superposition and mutual interaction, and evaluation of damage effects (due to impact, etc.) on the section stress pattern. Assessment of prestressed concrete structures should be carried out in accordance to appropriate national standards.

Alternative to this, a simplified approach can be adopted, in which all time-dependent effects are lumped into a single reduction coefficient, applied to the tendon stress, from which the pre-strengthening stress/deformation state is computed. Parametric studies are needed to quantitatively evaluate the consequences of such approximation on the design outcome, both in economical terms and from the safety standpoint, though, in general, it can be anticipated that such abrupt simplifications should be avoided in favour of more detailed preliminary assessment studies, especially in those cases where either many construction phases have followed one another or impact damage has changed the internal equilibrium configuration by activating a stress redistribution.

Different problems arise for the (less common) case of short-term FRP-strengthening, e.g., when prestressed elements do not pass the load test, due to either under-design or execution errors. In these cases, the design of the FRP reinforcement requires a slightly more complex study, because all long-term phenomena are still to develop and therefore they should be accounted for in the long-term effectiveness evaluation of the strengthening.

4.8.1.2 Considerations on the safety verifications

Once the existing stress state assessment has been correctly carried out, the conventional verification procedures currently adopted for prestressed concrete can be applied, according to the national standards, provided the FRP contribution is appropriately accounted for, in the same way as already explained in the section relative to reinforced concrete. Therefore, the usual verifications for concrete and steel of prestressed sections will not be repeated here, and also the reference values for the allowable stresses will not be indicated, inviting the reader to refer to the relevant national codes. Only issues peculiar to the case of FRP strengthening will be commented on, for both traditional performance levels: the serviceability limit state and the ultimate one.

The basis of design of the FRP-strengthening shall generally be limit state, except where limitations are placed on cracking when the design shall be checked according to the serviceability limit state.

At the serviceability limit state, the verifications should be performed with respect to the usual stress limits for concrete and steel, given by the national codes, whereas for FRP, the appropriate R coefficients should be adopted, as discussed in a previous paragraph. A still debated issue from the strengthening design philosophy standpoint is the possibility of admitting the presence of tensile stresses in the prestressed concrete section after the FRP-strengthening intervention. Such a decision would imply, as a consequence, the necessity of performing cracking verifications; in these latter, the role of the (non-prestressed) externally bonded FRP in reducing cracking in the tensile regions still needs to be ascertained and quantified.

At the ultimate limit state, the most compelling research issue, as is also the case for conventional reinforced concrete, regards the design partial safety factors calibration, which strongly influences the design process quality. Reliability-based studies should be carried out that keep the same FRP material factors as for reinforced concrete and aim at the calibration of other sectional capacity factors that ensure fulfillment of the limit states within a specified exceedance probability.

Another important aspect to be considered in the establishment of a design procedure is the determination of the initial strain at the prestressed element soffit where the FRP strengthening is to be applied. The actual FRP strain should be computed by subtracting the initial strain to the strain obtained from the plane section hypothesis, due to the discontinuity at the FRP-concrete interface. While this operation brings irrelevant improvement when verifying the serviceability limit state, it is absolutely necessary at the ultimate limit state, because the FRP rupture event determines the member collapse event (and thus the safety level) and therefore it should be computed as accurately as possible. Of course, in case appropriate measures have been taken, such as props and buttresses to recover the existing deflection prior to applying the FRP strengthening, the initial strain at the FRP-concrete interface can be considered as zero.

4.8.1.3 Considerations on the modelling issues

The development of design equations for FRP-strengthening of prestressed concrete sections relies on the availability of accurate models that can be used to numerically verify the effectiveness of the design procedures, both at short and long term. Fibre-section models lend themselves easily to this task, because all long-term phenomena can be described at the material level and subsequently integrated over the section and then over the finite element to obtain the global response. Such models should include all issues discussed above, which inevitably increase the complexity of both the formulation and the implementation. In first instance, all local and global degrees of freedom (dof) should be considered as split, as usual, into an “instantaneous” and a “time-dependent” part, which are added to give the total

deformation. Secondly, in order to consider different construction phases (section regions cast at different times), the number of local (section) and global (element) unknowns increases accordingly (for instance, 2 dof for the girder + 2 dof for the slab), whilst additional plane-section-type compatibility equations should be established on the deformation increments, rather than on the total deformations, in all section regions.

4.8.2 EBR in compression

The elastic modulus of FRP in compression is, in general, lower than that in tension. Moreover, typical EBR configurations have very low flexural rigidity, so that local buckling may occur at relatively low stress levels. It is generally felt that FRP should not be used as compression reinforcement. However, at certain instances FRP may be subjected to compressive stresses which may be of secondary importance but not negligible. One example is illustrated in Fig. 4-16, where the FRP over the support extends to positive moment regions. Other examples may be found in cases of column strengthening.

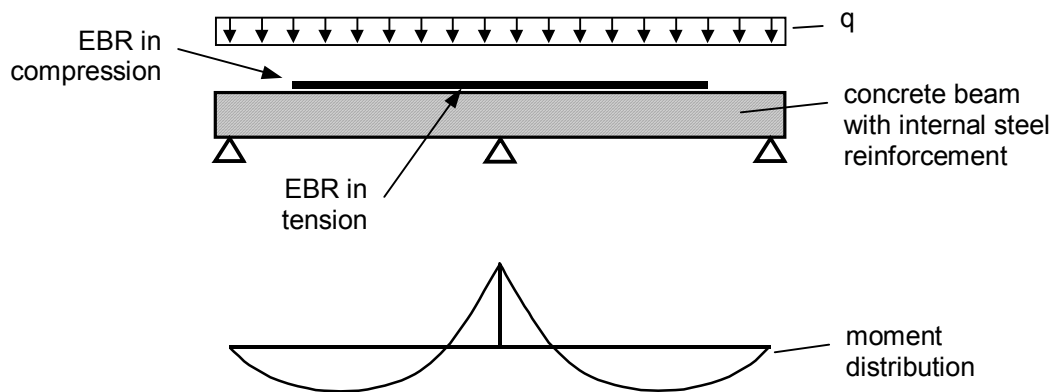

Fig. 4-16: Example of an unintentional use of EBR in compression.

The experimental database regarding the behaviour of EBR in compression is poor. One test with an FRP laminate glued in the compression zone of a RC beam is reported by Deuring (1993). In this test no buckling failure of the laminate was observed before the concrete failed in compression itself. But the beam was designed to fail due to yielding of the tension steel reinforcement without taking the EBR in compression into account. Other tests performed at the EMPA with CFRP laminates bonded on simply supported aluminium beams demonstrated that premature local buckling of the CFRP is a possibility (Kim and Meier 1991, Triantafillou et al. 1991).

The analysis of FRP local buckling would involve idealising the FRP as an elastic thin strip supported over an elastic medium of high rigidity. Initial efforts to address the problem are currently under way, but no firm results are available. Local buckling may be avoided by placing compressive stress limitations in the FRP (yet to be established), which are expected to be satisfied in many cases, as permanent compressive stresses in concrete should be kept low too, in order to prevent excessive creep deformations. Otherwise, FRP should either not be glued in compression zones or special devices (e.g. external clamps) should be provided to fix the reinforcement against buckling.

4.8.3 Strengthening with prestressed FRP

4.8.3.1 Design

Conventional reinforced concrete theory may be applied to determine accurately the cracking and yield loads of beams with prestressed strips in flexure provided that the initial stress in the strip is included in the calculations. However, premature failure by other failure modes, as described above, must be examined. As the ultimate load in flexure is approached, cracking of the concrete will inevitably occur and the section will revert to normal reinforced concrete behaviour. In this case the ultimate shear strength of a beam strengthened with a stressed strip will be the same as that of the original beam.

In calculating the shear resistance, the contribution of the strip to dowel action must be ignored unlike the main tensile steel reinforcement that can be included. The reason for this is that any vertical movement may lead to peeling-off failure resulting in debonding of the strip from the concrete. To be effective the strip would need to be enclosed by the shear links.

The ultimate flexural strength of a beam with a stressed strip will not markedly differ from that of a beam with an unstressed strip. However, the initial strain in the strip will be added to that induced by bending so that strip failure is more likely and the failure mode of “steel yielding followed by FRP fracture” may be activated.

4.8.3.2 Prestress losses

Losses in prestress should be taken into account and may arise from the following reasons:

- Relaxation of the steel tendons (the relaxation of prestressing steel is in the order of 5%) and the prestressed FRP EBR (the relaxation depends on the type of FRP; compared to prestressing steel the relaxation of CFRP is lower, of GFRP has the same magnitude and of AFRP is higher).
- Immediate elastic deformation of the concrete that occurs when the prestress is transferred into the beam, about 2 - 3%. Strips that have already been prestressed will experience a loss of prestress due to the shortening of the beam upon the prestressing of subsequent strips. If the prestress is applied by reacting against the member there will be no loss. The principles of conventional prestressing will apply.
- Creep and shrinkage of the concrete under compressive prestress over the service life of the structure, about 10 - 20%. This loss will be similar to conventional prestressing.
- Slippage of the tendons at their ends that occurs when the prestress is transferred into the anchorages. The method of anchoring FRP strips will determine whether a loss is likely similar to the pull in of wedges as for steel tendons.
- Friction between the duct and the tendon in conventional prestressing with steel tendons. With a stressed strip acting on the soffit of a beam, the camber of the beam will probably ensure that the strip does not touch the concrete and so there is no friction (this is the case in unbonded FRP EBR). If the strip does touch the concrete, this loss must be allowed for but if the adhesive acts as a lubricant the loss will be lower than for conventional prestressing.

4.8.3.3 FRP end anchorage

Tests have shown that only about 6% of the ultimate strength of the strip can be transferred into the concrete by the adhesive alone (e.g. Triantafillou et al. 1992, Deuring 1993). Detailed analytical treatment of this problem may be found in Triantafillou and Deskovic (1991). Prestressing forces greater than this require an adequate anchor system to transfer the stressing force into the member to avoid peeling-off at the end of the strip. Prestressing forces of up to 50% of the ultimate strength of the strip have been used in tests. Until verification by further tests, the value of 50% of the ultimate strength of the plate should not be exceeded based on tensile tests on the full section of the strip. Where the tests are based on the ultimate strength of coupon specimens this value should not exceed 33%. Newly developed systems for anchorage must be investigated with appropriate tests. The fixing bolts for the anchorage system must be designed to take the full prestressing force and must penetrate the beam an adequate distance beyond the reinforcing steel.

APPENDIX - ULS VERIFICATION OF PEELING-OFF AT THE END ANCHORAGE AND AT FLEXURAL CRACKS

A.1 Approach 1: Anchorage verification and FRP strain limitation

One approach to prevent peeling-off is restricting the ultimate tensile strain $\varepsilon_{f,lim}$ at ULS to a certain value. In addition to this, the end anchorage has to be verified using methods mainly based on fracture mechanics and bond stress - slip relationships (e.g. Pichler 1993, Täljsten 1994, Holzenkämpfer 1994, Neubauer and Rostásy 1997, Niedermeier 2000). The strain limitation approach has been incorporated in quite a few design guidelines and technical approvals, with $\varepsilon_{f,lim}$ ranging from 0.0065 to 0.0085 (e.g. German Institute of Construction Technology Authorizations, 1997, 1998, 2000a, 2000b).

Recent test results have demonstrated that the FRP tensile strain when peeling-off occurs depends on a broad range of parameters, such as the properties of the EBR and the concrete, the loading pattern, the crack spacing, etc. A global strain limit may not be suitable to represent the whole range of applications. Therefore the strain limitation in some cases could lead to a non-economical use of the FRP EBR, especially when strengthening large spans. Hence in the near future the strain limitation model will be replaced by more accurate ones, which will be based on extensive test data as well as analytical calculations. Two of the proposed models which will provide a more realistic prediction of EBR peeling-off and a more economical use of the EBR are presented in the following two sections.

As an example for the verification of the end anchorage, in the following the model of Holzenkämpfer (1994), as modified by Neubauer and Rostásy (1997), is presented. This model, based on the bond law of Fig. 4-8, gives the maximum FRP force which can be anchored, $N_{fa,max}$, and the maximum anchorage length, $\ell_{b,max}$, equal to:

$$N_{fa,max} = \alpha c_1 k_c k_b b \sqrt{E_f t_f f_{ctm}} \quad (\text{N}) \quad (\text{A1-1})$$

$$\ell_{b,max} = \sqrt{\frac{E_f t_f}{c_2 f_{ctm}}} \quad (\text{mm}) \quad (\text{A1-2})$$

where α is a reduction factor, approximately equal to 0.9, to account for the influence of inclined cracks on the bond strength (Neubauer and Rostásy 1999) (note that $\alpha = 1$ in beams with sufficient internal and external shear reinforcement and in slabs); k_c is a factor accounting for the state of compaction of concrete (k_c can generally be assumed to be equal to 1.0, but for FRP bonded to concrete faces with low compaction, e.g. faces not in contact with the formwork during casting, $k_c = 0.67$) and k_b is a geometry factor:

$$k_b = 1.06 \sqrt{\frac{2 - \frac{b_f}{b}}{1 + \frac{b_f}{400}}} \geq 1 \quad (\text{A1-3})$$

with $b_f/b \geq 0.33$. Note that b , b_f and t_f are measured in mm, and E_f , f_{ctm} are in MPa. c_1 and c_2 in eq. (A1-1) and (A2-2) may be obtained through calibration with test results; for CFRP strips they are equal to 0.64 and 2, respectively.

For bond lengths $\ell_b < \ell_{b,max}$, the ultimate bond force was calculated according to

Holzenkämpfer (1994) as follows:

$$N_{fa} = N_{fa,max} \frac{\ell_b}{\ell_{b,max}} \left(2 - \frac{\ell_b}{\ell_{b,max}} \right) \quad (A1-4)$$

A.2 Approach 2: Calculation of the envelope line of tensile stress

A more detailed approach to prevent peeling-off at flexural cracks in case of short-term static loading is proposed by Niedermeier (2000). The aim of this approach is to calculate the maximum possible increase in tensile stress within the EBR, which can be transferred by means of bond stresses between two subsequent flexural cracks. This increase shall be compared to the increase according to the design assuming full composite action (Fig. A2-1). Test results demonstrate that debonding and peeling-off initiate at flexural cracks when the tensile stress in the EBR exceeds the value that can be transferred by bond stresses. As the crack spacing has an important influence on the build up of tensile stresses, it is necessary to make assumptions about the spacing of cracks at ULS.

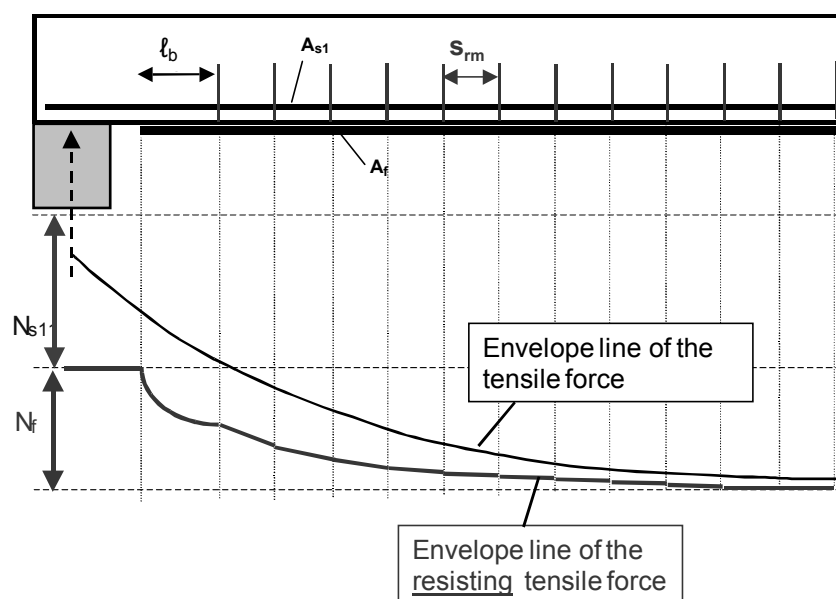

Fig. A2-1: Envelope line of the resisting tensile forces.

The basic approach consists of three steps (Fig. A2-2):

- Determination of the most unfavourable spacing of flexural cracks.
- Determination of the tensile force within the EBR between two subsequent cracks according to the design in bending (see Section 4.4.1).
- Determination of the maximum possible increase in tensile stress in the EBR.

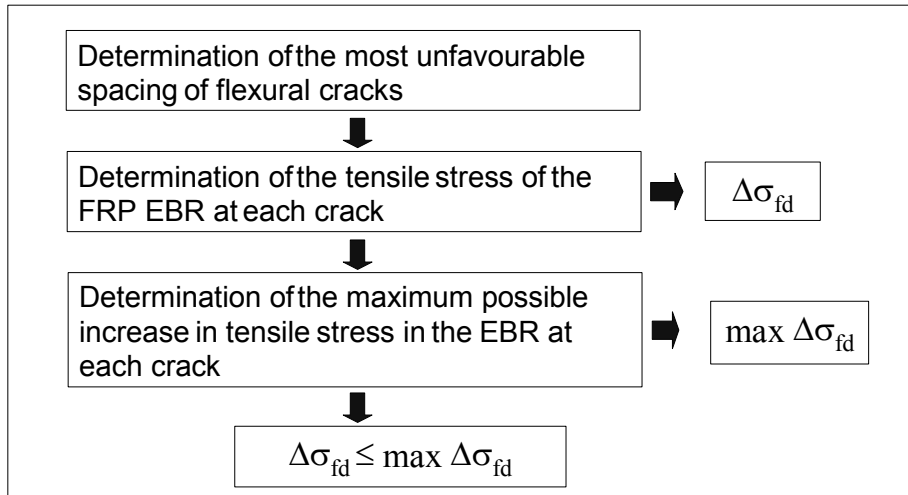

Fig. A2-2: Basic approach - flow chart.

- Determination of the most unfavourable spacing of flexural cracks

The crack spacing between two subsequent cracks equals 1 to 2 times the transmission length ℓ_t and may be calculated assuming constant mean bond stresses of both the internal and the external reinforcement. The mean bond stress of the internal reinforcement τ_{sm} can be determined according to EC2 [eq. (A2-1) in case of high bond action] whereas the mean bond stress of the external reinforcement can be estimated with eq. (A2-2). The transmission length may be calculated with Eqs (A2-3)-(A2-5), where M_{cr} is the bending moment causing cracking. In eq. (A2-4) the factor k takes into account, among others, the higher value of the flexural tensile strength $f_{ct,fl}$ when compared to the axial tensile strength or the tensile strength of the concrete surface. In this case k should equal 2.0 (EC2). The mean lever arm z_m may be determined taking into account the axial stiffness of the different layers of reinforcement [eq. (A2-5)]. To simplify the calculation, a constant crack spacing over the whole length of the flexural member may be assumed. As the bond stresses which can be transferred in an uncracked concrete zone (i.e. anchorage zone or between two subsequent cracks) is restricted due to the limitation of fracture energy, large crack spacing is unfavourable. Hence the crack spacing may correspond to 2 times the transmission length.

$$\tau_{sm} = 2.25f_{ctk,0.95} = 1.85f_{ctm} \quad (A2-1)$$

$$\tau_{fm} = 0.44f_{ctm} \quad (A2-2)$$

$$s_{rm} = 2\ell_t = 2 \frac{M_{cr}}{z_m} \frac{1}{\left(\sum \tau_{fm} b_f + \sum \tau_{sm} d_s \pi \right)} \quad (A2-3)$$

$$M_{cr} = \frac{kf_{ctk,0.95}bh^2}{6} \quad (A2-4)$$

$$z_m = 0.85 \frac{(hE_f A_f + dE_s A_{s1})}{(E_f A_f + E_s A_{s1})} \quad (\text{A2-5})$$

- Determination of the tensile stress of the FRP EBR at each crack

In accordance with Section 4.4.1, the tensile stress has to be calculated taking into account strain compatibility and internal force equilibrium. The shift rule according to EC2 has to be applied.

- Determination of the maximum possible increase in tensile stress in the EBR

To verify that the growth in tensile stresses between two subsequent cracks as calculated in the design for bending (Section 4.4.1) does not exceed the maximum possible increase determined by the bond stresses, the achievable increase has to be estimated. This has to be done for the region where flexural cracks occur as well as for the anchorage zone.

The maximum tensile force, which can be transferred from the EBR to the concrete by means of bond stresses at the anchorage zone (Fig. A2-3), can be calculated according to Niedermeier (2000) with eq. (A2-6) - (A2-8).

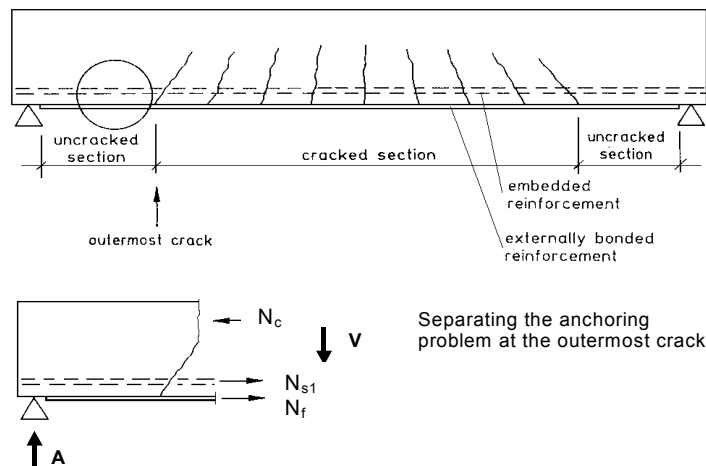

Fig. A2-3: End anchorage in an uncracked concrete zone.

$$\sigma_{fad,max} = \frac{c_1}{\gamma_c} \sqrt{\frac{E_f \sqrt{f_{ck} f_{ctm}}}{t_f}} \quad [\text{MPa}] \quad (\text{A2-6})$$

In eq. (A2-6) c_1 equals $\boxed{0.23}$. The maximum possible stress is closely related to an effective anchorage length $\ell_{b,max}$ [eq. (A2-7)],

$$\ell_{b,max} = c_2 \sqrt{\frac{E_f t_f}{\sqrt{f_{ck} f_{ctm}}}} \quad [\text{mm}] \quad (\text{A2-7})$$

where $c_2 = \boxed{1.44}$.

An increase in anchorage length above $\ell_{b,max}$ does not result in an increase in resisting tensile stresses (Fig. A2-4). This is due to the limitation of fracture energy as observed by

many researchers, e.g. Holzenkämpfer (1994) or Neubauer and Rostásy (1997). For anchorage lengths lower than $\ell_{b,max}$, the maximum tensile stress is described by eq. (A2-8) (Fig. A2-4):

$$\sigma_{fad} = \frac{\ell_b}{\ell_{b,max}} \left(2 - \frac{\ell_b}{\ell_{b,max}} \right) \cdot \sigma_{fad,max} \quad \ell_b \leq \ell_{b,max} \quad (A2-8)$$

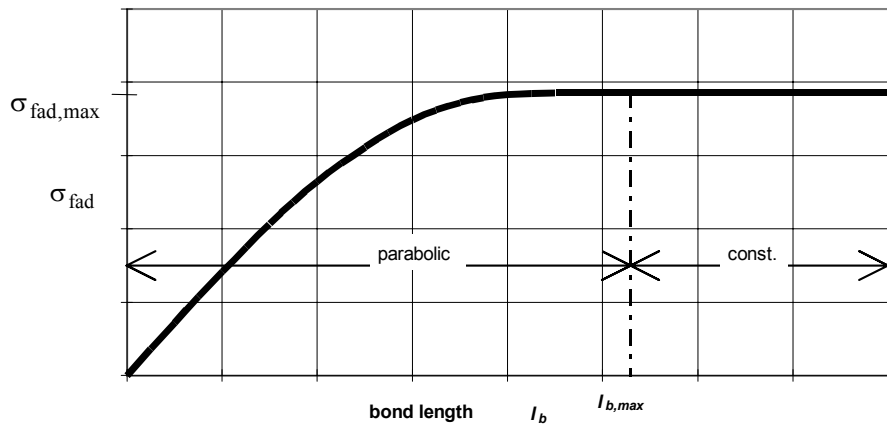

Fig. A2-4: Anchorable tensile stress related to anchoring length (Niedermeier 2000).

An analysis of the bond behavior of the EBR based on a simplified bilinear bond stress – slip relation leads to equations which can be used to calculate the maximum increase in tensile stress $\max \Delta\sigma_{fd}$ in an element between two cracks depending on the tensile stress σ_{fd} . σ_{fd} is the tensile stress as determined based on strain compatibility and force equilibrium (the shift rule has to be applied here) at the section where the lower tensile stresses act (Fig. A2-5).

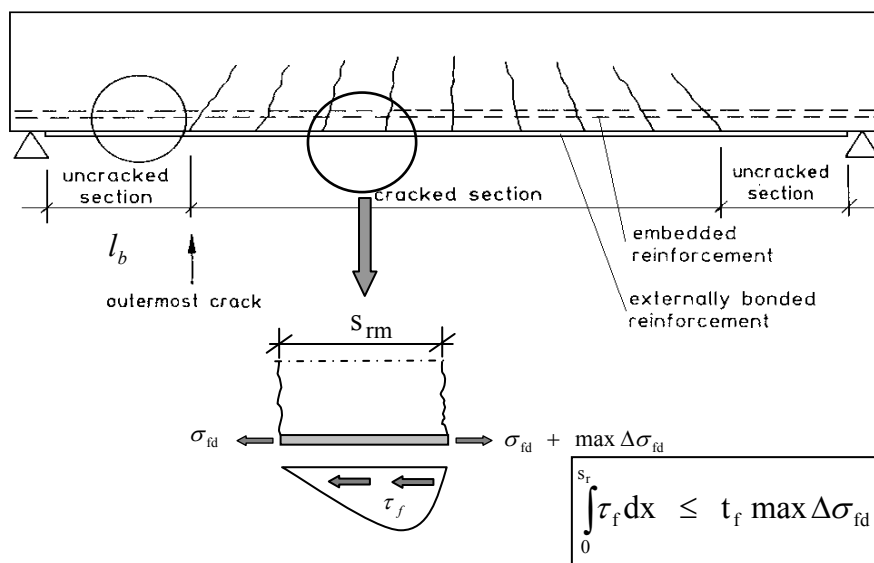

Fig. A2-5: Element between two subsequent cracks – analysis of peeling-off at flexural cracks.

In Fig. A2-6 the maximum possible increase depending on a specific crack spacing is shown.

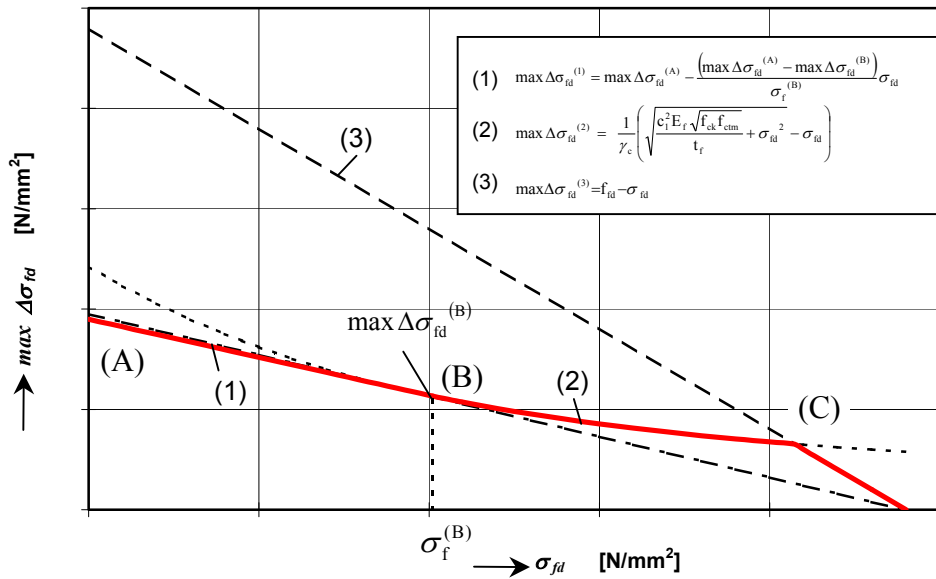

Fig. A2-6: Diagram of the maximum possible increase in tensile stress between two subsequent cracks (Niedermeier 2000).

The points A, B and C shown in the diagram may be estimated using the following equations. In Fig. A2-6 point A corresponds to the verification at the end anchorage where $\sigma_{fd} = 0$. The matching maximum increase in stress - or in this case, the maximum anchorable tensile stress $\max \Delta \sigma_{fd}^{(A)}$ - can be estimated from eq. (A2-6) - (A2-8). $\sigma_f^{(B)}$ can be calculated with eq. (A2-9) and the related maximum increase $\max \Delta \sigma_{fd}^{(B)}$ can be estimated from eq. (A2-10).

$$\sigma_f^{(B)} = \frac{c_3 E_f}{s_{rm}} - c_4 \sqrt{f_{ck} f_{ctm}} \frac{s_{rm}}{4 t_f} \quad [\text{MPa}] \quad (\text{A2-9})$$

$$\max \Delta \sigma_{fd}^{(B)} = \frac{1}{\gamma_c} \left[\sqrt{\frac{c_1^2 E_f \sqrt{f_{ck} f_{ctm}}}{t_f} + (\sigma_f^{(B)})^2} - \sigma_f^{(B)} \right] \quad [\text{MPa}] \quad (\text{A2-10})$$

with $c_3 = \boxed{0.185}$ and $c_4 = \boxed{0.285}$. The linear decrease between points A and B can then be described by eq. (A2-11). The graph between B and C is determined by eq. (A2-12).

$$\max \Delta \sigma_{fd}^{(1)} = \max \Delta \sigma_{fd}^{(A)} - \frac{(\max \Delta \sigma_{fd}^{(A)} - \max \Delta \sigma_{fd}^{(B)})}{\sigma_f^{(B)}} \sigma_{fd} \quad (\text{A2-11})$$

$$\max \Delta \sigma_{fd}^{(2)} = \frac{1}{\gamma_c} \left[\sqrt{\frac{c_1^2 E_f \sqrt{f_{ck} f_{ctm}}}{t_f} + \sigma_{fd}^2} - \sigma_{fd} \right] \quad [\text{MPa}] \quad (\text{A2-12})$$

For high tensile stresses, the upper limit of the increase in stresses is determined by the tensile strength of the FRP, eq. (A2-13) (see Fig. A2-6).

$$\max \Delta \sigma_{fd}^{(3)} = f_{fd} - \sigma_{fd} \quad (\text{A2-13})$$

Note that in eq. (A2-6) - (A2-12) the units are MPa for stress and modulus of elasticity and mm for dimensions.

The proposed factors c_1 , c_2 , c_3 , c_4 and k are obtained by calibrating (linear regression analysis) the bond model by means of simplified bond tests as described in Section 4.2.2.2. They are subject to further study and may change in the future when more test data will become available. Note that these parameters are closely related to the basic bond stress – slip relation shown in Fig. A2-7,

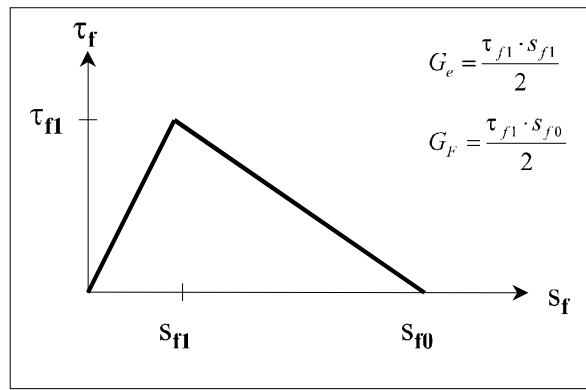

Fig. A2-7: Bond stress – slip relation.

where:

$$\tau_{f1d} = \frac{c_4}{\gamma_c} \sqrt{f_{ck} f_{ctm}} \quad \text{is the maximum bond stress,}$$

$$s_{f0d} = c_3 = c_1^2 / c_4 \quad \text{is the slip where debonding occurs,}$$

$$G_{Fd} = 0.5 \tau_{f1d} s_{f0d} = 0.5 \frac{c_1^2}{\gamma_c} \sqrt{f_{ck} f_{ctm}} \quad \text{is the fracture energy of concrete.}$$

A.3 Approach 3: Verification of anchorage and of force transfer between FRP and concrete

This approach comprises two steps. The first involves verification of the end anchorage, as in A.1. In the second step it should be verified that the shear stress τ_b at the FRP-concrete interface, resulting from the change of tensile force along the FRP, is limited (Matthys 2000). Considering two cross sections at distance Δx , subjected to moments M_d and $M_d + \Delta M_d$, τ_b equals:

$$\tau_b = \frac{\Delta N_{fd}}{b_f \Delta x} \quad (\text{A3-1})$$

where ΔN_{fd} is the change in FRP axial force between the two sections. For the verification of the ULS the shear stress τ_b should be restricted to the design bond shear strength, which is equal (in most practical cases) to the bond shear strength of concrete, f_{cbd} . Adopting the Mohr-Coulomb failure criterion in the case of zero normal stress, the bond strength equals about 1.8 times the tensile strength, that is:

$$f_{cbd} = 1.8 \frac{f_{ctk}}{\gamma_c} \quad (A3-2)$$

Equation (A3-1) can be simplified considering that $N_{rd}=M_d/z_m$ and $N_{rd}=N_{fd}+N_{sd}$. Depending on whether the internal steel has yielded or not, N_{rd} and ΔN_{fd} can be approximated as:

$$\varepsilon_{s1} < \varepsilon_{yd} : N_{rd} = N_{fd} \left(1 + \frac{A_{s1} E_s \varepsilon_s}{A_f E_f \varepsilon_f} \right) \approx N_{fd} \left(1 + \frac{A_{s1} E_s}{A_f E_f} \right) \text{ or } \Delta N_{fd} \approx \frac{\Delta M_d}{z_m \left(1 + \frac{A_{s1} E_s}{A_f E_f} \right)} \quad (A3-3 \text{ a})$$

$$\varepsilon_{s1} \geq \varepsilon_{yd} : N_{rd} = N_{fd} + A_{s1} f_{yd} \quad \text{or } \Delta N_{fd} = \frac{\Delta M_d}{z_m} \quad (A3-3 \text{ b})$$

With $\Delta M_d/\Delta x \approx V_d$ (design shear force) and $z_m=(z_s+z_f)/2 \approx 0.95d$, this gives the following conditions:

$$\varepsilon_{s1} < \varepsilon_{yd} : \frac{V_d}{0.95db_f \left(1 + \frac{A_{s1} E_s}{A_f E_f} \right)} \leq f_{cbd} \quad (A3-4 \text{ a})$$

$$\varepsilon_{s1} \geq \varepsilon_{yd} : \frac{V_d}{0.95db_f} \leq f_{cbd} \quad (A3-4 \text{ b})$$

In eq. (A3-3 a) it was assumed that $\varepsilon_{s1}/\varepsilon_f \approx 1$. From eq. (A3-4 a) it can be noted that this assumption is on the safe side. Due to the substantial width of the bond interface normally available, the verification according to eq. (A3-4) is typically not critical. Bond problems may occur in case the internal steel is yielding or high shear forces develop.

A key assumption of this approach is that if the above condition is verified flexural cracks will only produce stable micro-cracking at the FRP-concrete interface and local debonding, which will not result in bond failure. Hence no additional limitation on the FRP strain should apply.

5 Strengthening in shear and torsion

5.1 Strengthening in shear

5.1.1 General

Shear strengthening of RC members using FRP may be provided by bonding the external reinforcement with the principal fibre direction as parallel as practically possible to that of maximum principal tensile stresses, so that the effectiveness of FRP is maximised (see Fig. 5-1 for the dependence of the FRP elastic modulus, E_{fu} , on the fibre orientation). For the most common case of structural members subjected to lateral loads, that is loads perpendicular to the member axis (e.g. beams under gravity loads or columns under seismic forces), the maximum principal stress trajectories in the shear-critical zones form an angle with the member axis which may be taken roughly equal to 45° . However, it is normally more practical to attach the external FRP reinforcement with the principal fibre direction perpendicular to the member axis (Fig. 5-2, 5-3).

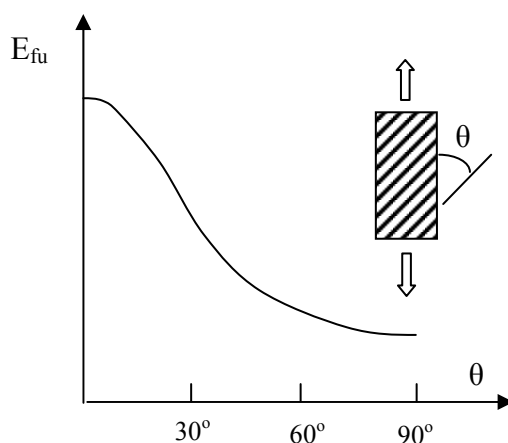

Fig. 5-1: Dependence of FRP elastic modulus on fibre orientation.

Detailed investigations on shear strengthening of RC members have been relatively limited and, to a certain degree, controversial. With a couple of exceptions, most researchers have idealised the FRP materials in analogy with internal steel stirrups, assuming that the contribution of FRP to shear capacity emanates from the capacity of fibres to carry tensile stresses at a more or less constant strain, which is equal either to the FRP ultimate tensile strain, ε_{fu} , or to a reduced value (e.g. 0.005 or a fixed fraction of ε_{fu}).

In recent studies, Täljsten (1998), Triantafillou (1998) and Triantafillou and Antonopoulos (2000) demonstrated that when the concrete member reaches its shear capacity (that is just before it fails in shear), the external FRP is stretched in the principal fibre direction up to a strain level, which is, in general, less than the tensile fracture strain ε_{fu} . This strain is defined as *effective strain*, $\varepsilon_{f,e}$ to reflect the fact that if it were multiplied by the FRP elastic modulus in the principal fibre direction, E_f , and the available FRP cross sectional area, it could provide the total force carried by the FRP at shear failure of the element.

The effective FRP strain is extremely difficult, if not impossible, to calculate based on rigorous analysis. But it may be estimated based on simple modelling and through detailed analysis of experimental data. Central to the estimation of $\varepsilon_{f,e}$ is the identification of the status of the FRP material at shear failure of the RC member. Note that failure is always defined by concrete *diagonal tension*. As Fig. 5-4 illustrates in a qualitative manner, this may occur

either prematurely, as a result of FRP *peeling-off*, or after the FRP has been stretched considerably. In the latter case the FRP may *fracture* either exactly at the peak load or a little after, due to overstressing in the vicinity of the diagonal cracks.

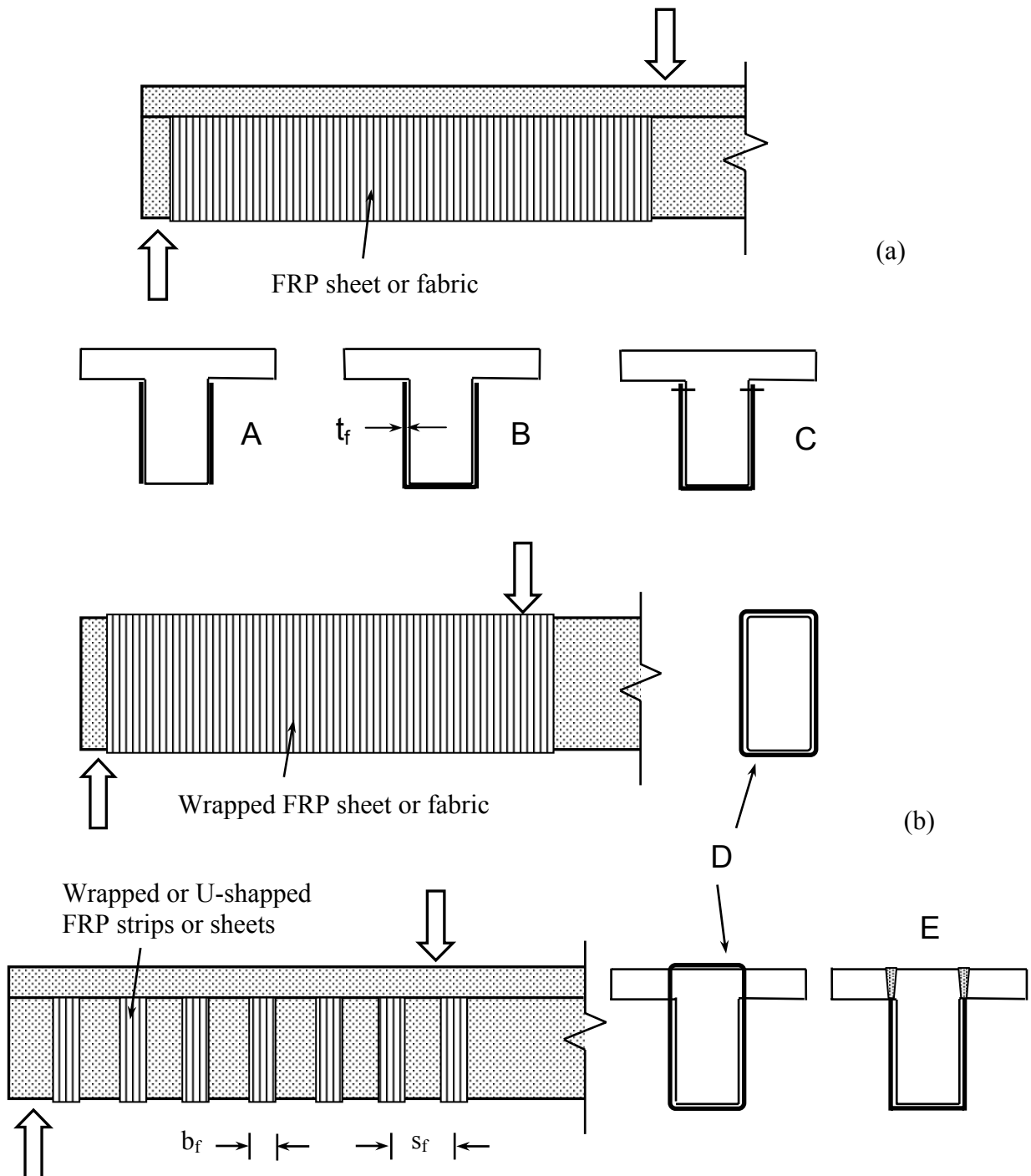

Fig. 5-2: Schematic illustration of reinforced concrete element strengthened in shear with FRP: (a) FRP sheets or fabrics bonded to the web; (b) wrapped or U-shaped FRP (the concept shown in D is applicable to both beams and columns).



(a)



(b)

Fig. 5-3: Shear strengthening of: (a) beam end; (b) short column.

It may be argued that at the ultimate limit state a certain degree of FRP debonding at the concrete-FRP interface is always expected, even if the ultimate failure does not occur simultaneously with peeling-off. This is attributed to excessive straining in the FRP, which results in strain incompatibilities with the substrate material (concrete) and subsequent cracking. Cracking, in turn, causes stress concentrations that produce local debonding. Hence, one may argue that $\varepsilon_{f,e}$ depends heavily on the FRP bonded length, its relation to the “effective bond length” (through which FRP-concrete interface shear bond stresses develop) and the relation of the latter to the “development length” (defined as that necessary to reach FRP tensile fracture before peeling-off). Apart from the bond conditions (surface preparation, execution etc.), the development length depends on the FRP axial rigidity, which may be expressed by the product $E_f \rho_f$, and is inversely proportional to the shear, that is to the tensile, strength of concrete. It is well established today that the tensile strength of concrete is proportional to $f_{cm}^{2/3}$, where f_{cm} is the compressive strength, so that one may finally argue that $\varepsilon_{f,e}$ depends on the quantity $E_{fu} \rho_f / f_{cm}^{2/3}$. This dependence may be established from experimental results, as described in Triantafillou and Antonopoulos (2000).

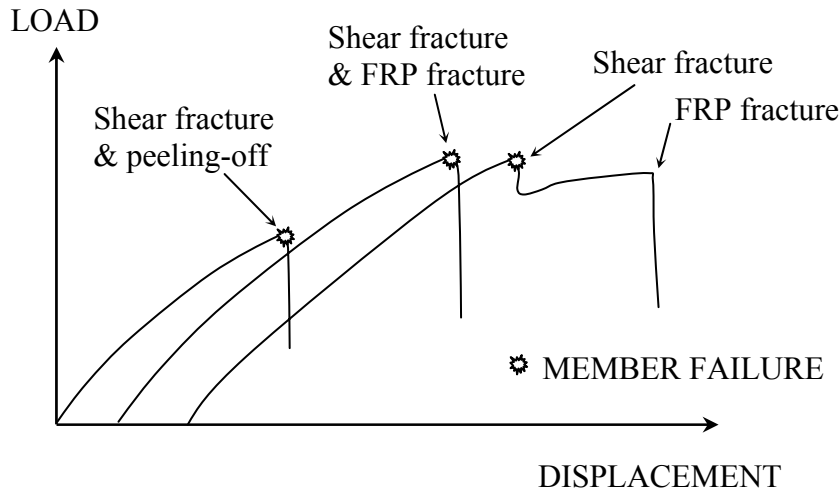

Fig. 5-4: Schematic illustration of shear failure response.

5.1.2 Design model in the ULS

5.1.2.1 Members of rectangular, T and double-T cross section

According to the model of Triantafillou (1998) and Täljsten (1999 a), the external FRP reinforcement may be treated in analogy to the internal steel (accepting that the FRP carries only normal stresses in the principal FRP material direction), assuming that at the ultimate limit state in shear (concrete diagonal tension) the FRP develops an effective strain in the principal material direction, $\varepsilon_{f,e}$ (note: this is not the principal tensile strain, which may be assumed perpendicular to the crack). The effective strain $\varepsilon_{f,e}$ is, in general, less than the tensile failure strain, ε_{fu} . Hence, the shear capacity of a strengthened element may be calculated according to the EC2 format as follows:

$$V_{Rd} = \min(V_{cd} + V_{wd} + V_{fd}, V_{Rd2}) \quad (5-1)$$

The FRP contribution to shear capacity, V_{fd} , can be written in the following form (Fig. 5-5):

$$V_{fd} = 0.9\varepsilon_{fd,e} E_{fu} \rho_f b_w d (\cot \theta + \cot \alpha) \sin \alpha \quad (5-2)$$

where

- $\varepsilon_{fd,e}$ = design value of effective FRP strain
- b_w = minimum width of cross section over the effective depth
- d = effective depth of cross section
- ρ_f = FRP reinforcement ratio equal to $2t_f \sin \alpha / b_w$ for continuously bonded shear reinforcement of thickness t_f (b_w = minimum width of the concrete cross section over the effective depth), or $(2t_f / b_w)(b_f / s_f)$ for FRP reinforcement in the form of strips or sheets of width b_f at a spacing s_f (Fig. 5-2)
- E_{fu} = elastic modulus of FRP in the principal fibre orientation
- θ = angle of diagonal crack with respect to the member axis, assumed equal to 45°
- α = angle between principal fibre orientation and longitudinal axis of member

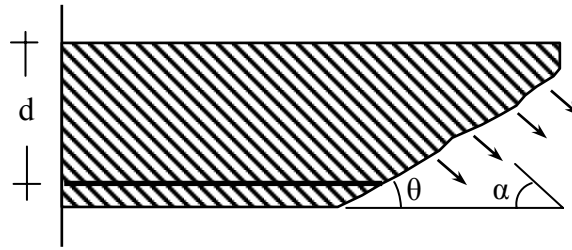

Fig. 5-5: Contribution of FRP to shear capacity.

The design value of the effective FRP strain equals the characteristic value, $\epsilon_{fk,e}$, divided by the partial safety factor γ_f . Given the lack of sufficient data, $\epsilon_{fk,e}$ may be approximated by multiplying the mean value of the effective FRP strain, $\epsilon_{f,e}$, by a reduction factor, say k .

$$\epsilon_{fk,e} = k \epsilon_{f,e} \quad k = \boxed{0.8} \quad (5-3)$$

The partial safety factor is taken from Table 3-1 if failure involves FRP fracture (combined with or following diagonal tension), or $\gamma_f = \gamma_{fb} = \boxed{1.30}$ if bond failure leading to peeling-off dominates.

Some researchers have proposed that the effective strain be limited to a maximum value, in the order of 0.006, to maintain the integrity of concrete and secure activation of the aggregate interlock mechanism (e.g. Priestley and Seible 1995, Khalifa et al. 1998, Antonopoulos and Triantafillou 2000). Such a limitation should be considered only if activation of this mechanism is of crucial importance.

A synthesis and evaluation of all the published experimental results (Fig. 5-6 and 5-7) on shear strengthening of RC members with FRP sheets or fabrics reported in the literature up to early 1999 resulted in the best fit power-type expressions given next (Triantafillou and Antonopoulos 2000).

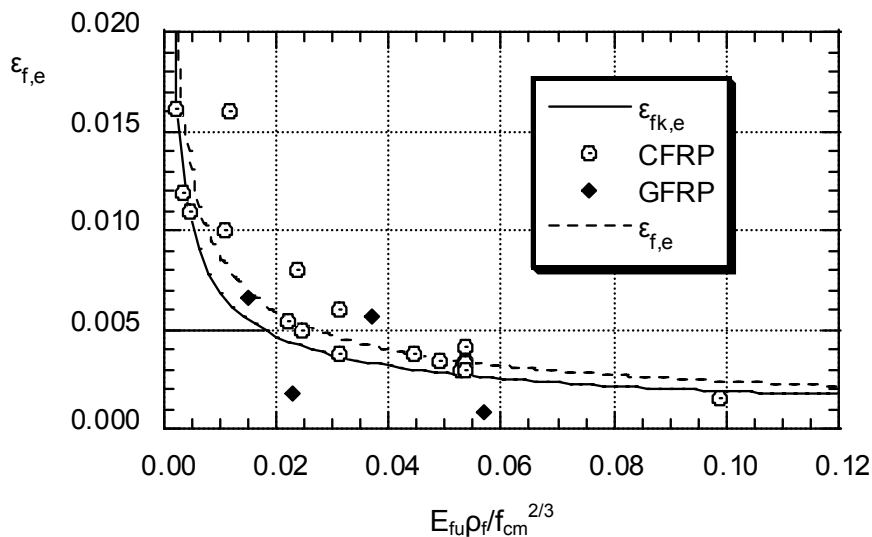

Fig. 5-6: Effective FRP strain in terms of $E_{fi}\rho_f/f_{cm}^{2/3}$ – shear failure combined with FRP debonding.

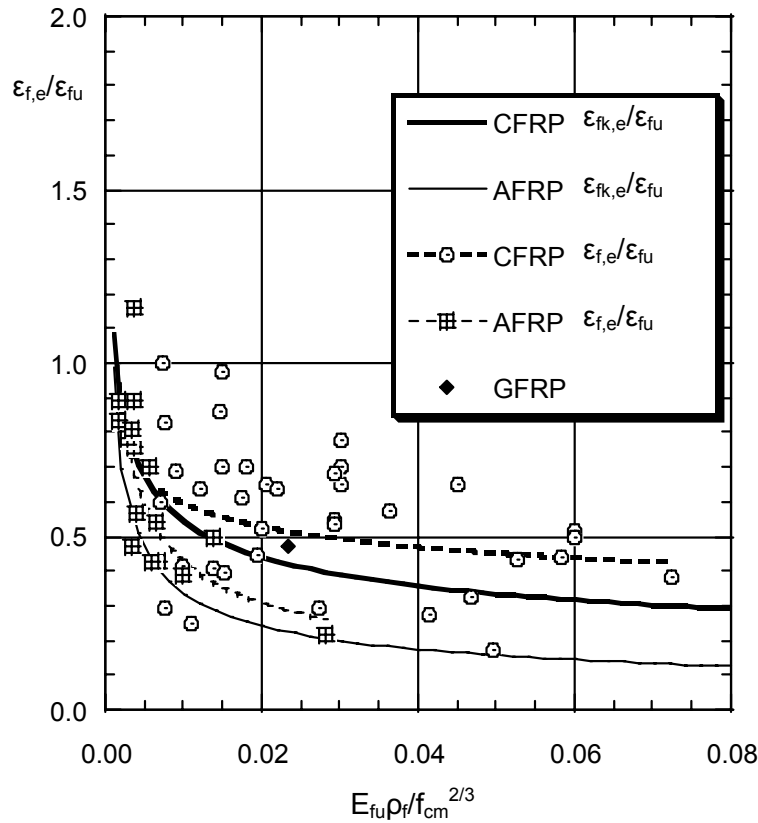

Fig. 5-7: Normalized FRP strain in terms of $E_{fu}\rho_f/f_{cm}^{2/3}$ – shear failure combined with or followed by FRP fracture.

- Fully wrapped (or properly anchored) CFRP - FRP fracture controls (Fig. 5-2 b):

$$\varepsilon_{f,e} = 0.17 \left(\frac{f_{cm}^{2/3}}{E_{fu}\rho_f} \right)^{0.30} \varepsilon_{fu} \quad (5-4 a)$$

- Side or U-shaped CFRP jackets (Fig. 5-2 a):

$$\varepsilon_{f,e} = \min \left[\underbrace{0.65 \left(\frac{f_{cm}^{2/3}}{E_{fu}\rho_f} \right)^{0.56}}_{\text{peeling-off}} \times 10^{-3}, \underbrace{0.17 \left(\frac{f_{cm}^{2/3}}{E_{fu}\rho_f} \right)^{0.30}}_{\text{fracture}} \varepsilon_{fu} \right] \quad (5-4 b)$$

- Fully wrapped AFRP (FRP fracture controls):

$$\varepsilon_{f,e} = 0.048 \left(\frac{f_{cm}^{2/3}}{E_{fu}\rho_f} \right)^{0.47} \varepsilon_{fu} \quad (5-4 c)$$

Note that in all equations f_{cm} is in MPa and E_{fu} is in GPa.

For most practical cases, the above equations for the effective FRP strain give values that are above the yield strain of internal stirrups. For the sake of completeness we should

mention that if this is not the case, then the effective FRP strain should also be used for the calculation of the contribution of the internal steel.

5.1.2.2 Design recommendations

A careful examination of the above equations (for CFRP only, as data for AFRP and GFRP are very limited), which are plotted in Fig. 5-8, leads to the conclusion that: (a) if failure is governed by peeling-off combined with shear fracture (e.g. side or U jackets) the increase in shear capacity with $E_{fu}\rho_f$ is relatively small but the concrete strength plays an important role; and (b) if failure is governed by shear fracture combined with or followed by CFRP fracture (e.g. fully wrapped jackets) the increase in shear capacity with $E_{fu}\rho_f$ becomes quite substantial, but the role of concrete is of secondary importance. It is clear that full wrapping is far more effective than partial jacketing. When full wrapping is not feasible (for instance, when there is no access to the top side of T-beams), it is recommended that FRP strips be attached to the compressive zone of the RC member. This may be accomplished by using simple mechanical anchors or by bonding the ends of the strips in core holes through the whole height of the flange of a T-beam.

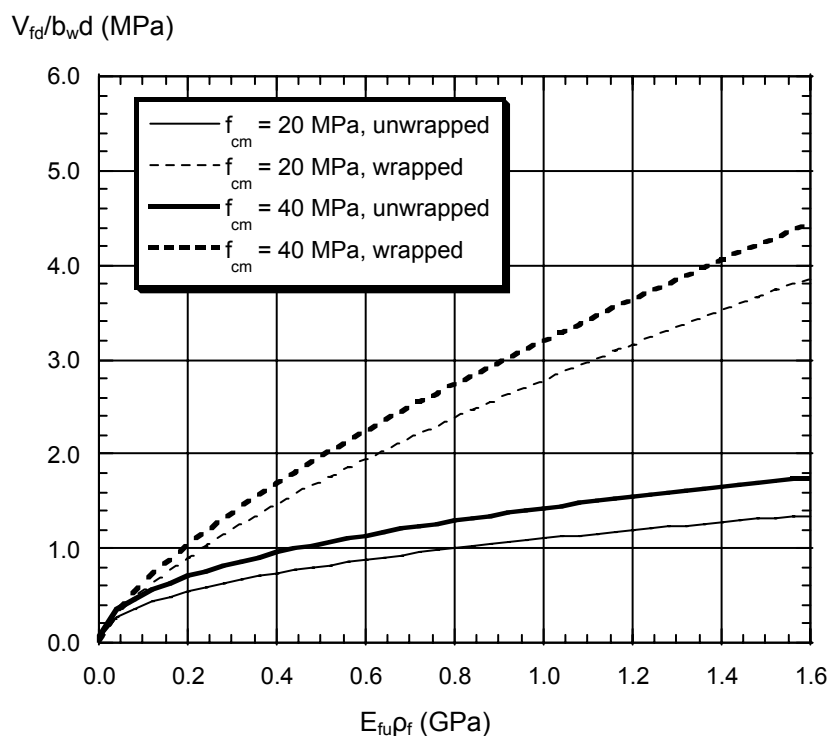

Fig. 5-8: CFRP contribution to shear capacity for two different concrete strengths and fully wrapped (properly anchored) versus unwrapped configurations.

As an additional recommendation towards the proper design of RC elements strengthened in shear with FRP we should point out that the spacing s_f of strips, if they are used vertically, should not exceed $(0.9d-b_f/2)$ for rectangular cross sections or $(d-h_f-b_f/2)$ for T-beams (with slab thickness equal to h_f), so that no diagonal crack may be formed without intercepting a strip.

5.1.2.3 Considerations on FRP bonded length

One drawback of the rather qualitative approach described above is that the FRP bonded length is not taken explicitly into account. But this may be (at least partially) justified in view of the following arguments: (a) for real size structures, the effective bond length is typically a small fraction of a RC member's depth, and hence the partially ineffective FRP comprises a rather small fraction of the total; (b) the effect of short FRP bonded lengths may be taken into account to a certain extent through the experimental data fitting and calibration procedure; and (c) additional complexity to an approach which is meant to be as simple as possible (for the sake of design calculations) may not be desirable. However, one could estimate the maximum force that may be carried by the FRP prior to debonding according to the concepts presented in Sections 4.2.2.2 and 4.3.2.1. An alternative approach has been proposed by Täljsten (1999 a).

5.1.2.4 Members of circular cross section

The material presented above refers mainly to RC members of rectangular (or nearly rectangular) cross sections. If the cross section is circular (e.g. some columns), the contribution of FRP (wrapped around the column) to shear capacity is controlled by the tensile strength of the FRP jacket, but may be limited to a maximum value corresponding to excessive dilation of the concrete due to aggregate interlock (one of the key shear force transfer mechanisms) at inclined cracks. By limiting the concrete dilation, that is the radial strain (which is equal to the FRP hoop strain) to a maximum value, say, ε_{\max} , one may easily show that for inclined cracks forming an angle θ with the column axis, the FRP contribution to shear capacity is as given below:

$$V_{fd} = \frac{\varepsilon_{\max}}{\gamma_f} E_{fu} \rho_f \frac{1}{2} \frac{\pi D^2}{4} \cot \theta \quad (5-5)$$

where D = column diameter and ρ_f = volumetric ratio of FRP. The derivation of eq. (5-5) is easily understood if one assumes that at shear failure all the FRP material crossing an inclined crack is strained uniformly at ε_{\max} . Experimental evidence suggests that ε_{\max} is in the order of 0.006 (Priestley and Seible 1995).

5.1.3 Servicability limit state

The externally bonded reinforcement should not debond at the serviceability limit state. This is important, so that problems related to moisture penetration, crack propagation, noise from debonding etc. may be avoided. To verify this, the strain in the FRP in the serviceability limit state, $\varepsilon_{fk,e}$, should be limited to $0.8f_{yk}/E_s$, unless otherwise provided and verified by the FRP system supplier.

5.2 Strengthening in torsion

5.2.1 General

Strengthening for increased torsional capacity may be required in conventional beams and columns, as well as in bridge box girders. The principles applied to strengthening in shear are also valid in the case of torsion, with a few minor differences, which will be highlighted in the following section.

5.2.2 Design model in the ULS – rectangular cross sections

Torsional cracks are formed due to the same mechanism that is responsible for the formation of shear cracks. The main difference between shear cracking and torsional cracking lies in the crack pattern. Torsional cracks are inclined, just like shear cracks, but they have different directions on opposite sides, following a spiral-like pattern (see Fig. 5-9). Hence, an FRP material placed with the fibres forming an angle α with respect to the member axis may be quite effective in arresting diagonal cracking on one side but ineffective on the other side. This point should be highlighted and taken properly into account in design.

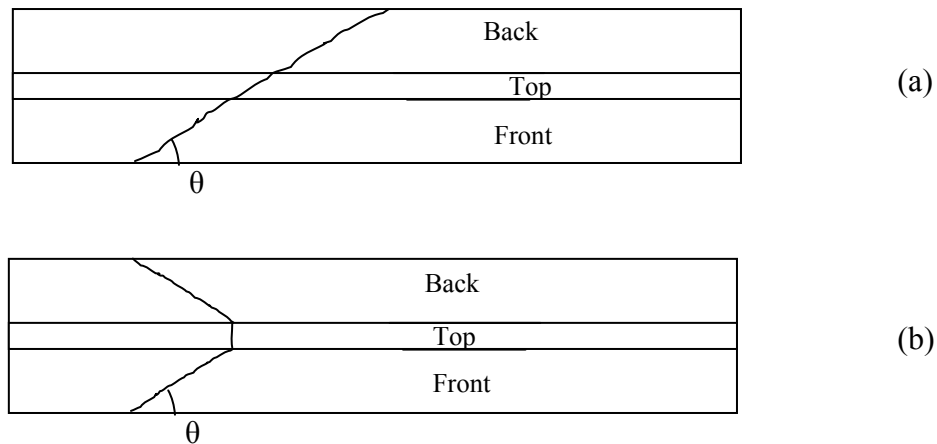

Fig. 5-9: (a) Torsional and (b) shear cracking.

An externally bonded FRP jacket will provide contribution to torsional capacity only if full wrapping around the element's cross section is applied, so that the tensile forces carried by the FRP on each side of the cross section may form a continuous loop (see Fig. 5-10). These forces are calculated below for the case $\alpha = 90^\circ$, in direct analogy with the shear calculations (that is assuming the validity of the truss mechanism).

$$F_{fd,v} = \varepsilon_{fd,e} E_{fu} \frac{t_f b_f}{s_f} h \cot \theta \quad (5-6 a)$$

$$F_{fd,h} = \varepsilon_{fd,e} E_{fu} \frac{t_f b_f}{s_f} b \cot \theta \quad (5-6 b)$$

Hence the contribution of FRP to torsional capacity, T_{fd} , is given by the following equation (Fig. 5-10):

$$T_{fd} = F_{fd,v}b + F_{fd,h}h = 2\varepsilon_{fd,e}E_{fu} \frac{t_f b_f}{s_f} bh \cot \theta \quad (5-7)$$

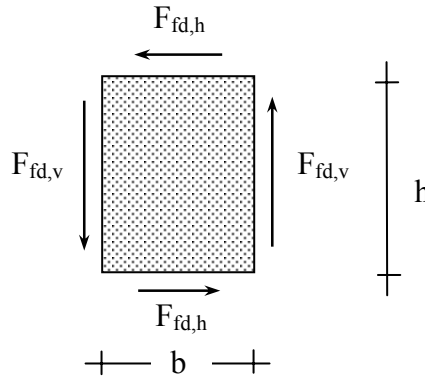

Fig. 5-10: Forces carried by the FRP reinforcement.

The design value of the effective FRP strain in the principal material direction is given as in the preceding analysis of shear for the case of fully wrapped FRP, $\varepsilon_{fd,e} = \varepsilon_{fk,e}/\gamma_f$, where:

$$\varepsilon_{fk,e} = k \varepsilon_{f,e} \quad k = \boxed{0.8} \quad (5-3)$$

The partial safety factor is taken from Table 3-1 if failure involves FRP fracture. If premature debonding leading to peeling-off dominates $\gamma_f = \gamma_{fb} = \boxed{1.30}$.

$$\text{CFRP: } \varepsilon_{f,e} = 0.17 \left(\frac{f_{cm}^{2/3}}{E_{fu} \rho_f} \right)^{0.30} \varepsilon_{fu} \quad (5-4 \text{ a})$$

$$\text{GFRP: } \varepsilon_{f,e} = 0.048 \left(\frac{f_{cm}^{2/3}}{E_{fu} \rho_f} \right)^{0.47} \varepsilon_{fu} \quad (5-4 \text{ c})$$

Testing of FRP-strengthened concrete elements in torsion has been very limited. Some tests have been conducted by Täljsten (1998), who demonstrated that torsional strengthening of beams with rectangular cross sections is feasible with CFRP wrapping.

5.2.3 Servicability limit state

As in the case of strengthening in shear, the externally bonded reinforcement should not debond at the servicability limit state. To verify this, the strain in the FRP, $\varepsilon_{fk,e}$, should be limited to $0.8f_{yk}/E_s$, unless otherwise provided and verified by the FRP system supplier.

6 Confinement

6.1 Introduction

Confinement is generally applied to members in compression, with the aim of enhancing their load carrying capacity or, in cases of seismic upgrading, to increase their ductility. Traditional confinement techniques rely on either steel hoops or steel jackets for upgrading. Indeed, it is well known that increasing the confinement action enhances the concrete strength and ductility and, in addition, prevents slippage and buckling of the longitudinal reinforcement. In seismic problems, existing upgrading (either strengthening or retrofitting) techniques are typically based on increasing the confinement pressure in either the potential plastic hinge region or over the entire member (e.g. Chai et al. 1991). This technique can also be useful in lap-splices zones.

Advanced FRP composite materials have only recently been recognized as reliable confinement devices for reinforced concrete elements. Several experimental studies on concrete confined with FRP have been carried out (Saadatmanesh et al. 1994, Nanni and Bradford 1995, Seible et al. 1995, Picher et al. 1996, Matthys et al. 1999) which confirm the viability of this solution. Current analytical and numerical research (Mirmiran and Shahawy 1997, Saadatmanesh et al. 1997, Spoelstra and Monti 1999, Matthys et al. 1999) aims at defining appropriate constitutive laws for FRP-confined models. In the field of design of FRP jackets extensive experimental work has been conducted by Seible et al. (1995), and numerical and analytical work by Monti et al. (1999), with the task of identifying suitable design equations that optimise the FRP jacket thickness as a function of the desired upgrading level. It should be emphasised that usually the increase in strength is not as significant as that in ductility. A recent review on the issue of upgrading through confinement may be found in Triantafillou (2001).

In the following reference is made to the material properties in general. For design, design values for the different strength values should be taken into account (Chapter 3).

6.2 Concrete confined by external FRP reinforcement under axial loading

6.2.1 General

FRP, as opposed to steel that applies a constant confining pressure after yield, has an elastic behaviour up to failure and therefore exerts its (passive) confining action on concrete specimens under axial load in a different way with respect to steel. In Fig. 6-1 it can be seen that at a certain value of the normalized axial concrete strain, the steel reaches yielding and then, from that point on, it exerts a constant lateral (confining) pressure, while FRP exerts a continuously increasing confining action.

The amount of this action depends on the lateral dilation of concrete, which in turn is affected by the confining pressure. Thus, FRP-confined concrete models should account for the interaction between the laterally expanding concrete and the confining device. Predictive equations of the ultimate strength and strain of FRP-confined concrete should also consider this peculiar behaviour.

In the following sections, the modelling of FRP-confinement will be discussed. Detailing rules, practical execution and quality control should meet also the requirements given in Chapters 7 and 8.

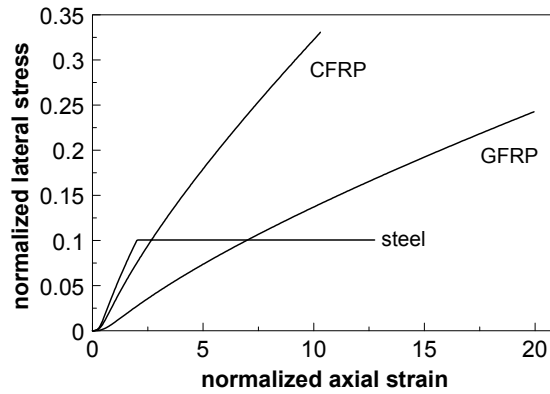

Fig. 6-1: Comparison of confinement actions of steel and FRP materials.

6.2.2 Effective ultimate circumferential strain

The ultimate strength of the confined concrete is closely related to the failure strain of the FRP wrapping reinforcement on the confined element. Experimental evidence shows that this circumferential failure strain mostly occurs at strains lower than the ultimate strain ϵ_{fu} obtained by standard tensile testing of the FRP sheet. This reduction is due to several reasons:

- *The triaxial state of stress of the wrapping reinforcement.* This is shown in Fig. 6-2, where the concept of *composite action* is introduced, which denotes the ability of the jacket of providing transverse confinement and, at the same time, longitudinal load-carrying capacity. It depends on the fibre arrangement and bond interface characteristics, which in turn depends on a large number of factors (such as the stiffness of the adhesive between FRP and concrete, surface preparation conditions). In case of no composite action, the jacket only undergoes transverse strains and therefore fails in extension mode, due to either fibre collapse or delamination between plies, at a circumferential strain ϵ_j slightly lower than ϵ_{fu} , because the stress gradient in the jacket due to the confinement pressure has also a certain influence on the ultimate strength. In case of full composite action, the jacket undergoes both transverse and longitudinal strains. The ultimate stress and strain are then reduced, with potential microbuckling and delamination to develop. Thus, failure of the specimen occurs at even lower circumferential strains than in case of no composite action.

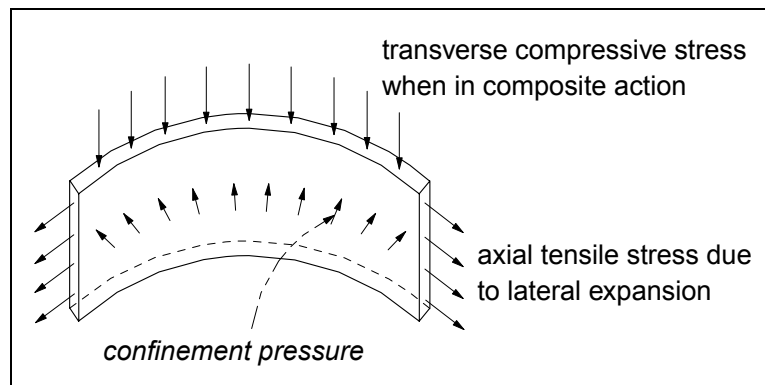

Fig. 6-2: Triaxial state of stress in FRP jackets.

- *The quality of the execution.* That is, if the fibres are locally ineffectively aligned due to voids or inadequate surface preparation, part of the circumferential strain is used to stretch the fibres. Also, fibres may be damaged at improperly rounded edges or local protrusions.
- *The curved shape of the wrapping reinforcement,* especially at corners with low radius.
- *Size effects* when applying multiple layers.

In the following, the effective ultimate circumferential strain, accounting for all of the above-mentioned effects, will be denoted as ε_{ju} ($j = \text{jacket}$). Proper design values for the effective ultimate circumferential strain ε_{ju} should be taken into account. So far, limited data on this issue are available. Hence, proper values of ε_{ju} should be justified by experimental evidence.

6.2.3 Lateral confining pressure

For uniaxially loaded cylindrical concrete specimens, confined with either steel hoop or spiral reinforcement, the effective confining pressure, f_ℓ , is calculated as a function of the transverse steel volumetric ratio ρ_{st} and its yield stress f_y , as follows (Fig. 6-3):

$$f_\ell = \frac{1}{2} k_e \rho_{st} f_y \quad \text{with} \quad \rho_{st} = \frac{4 A_{st}}{s d_s} \quad (6-1)$$

where k_e = arching effect coefficient, s = spacing (pitch) of hoops (spiral), A_{st} = cross-section of transverse steel, and d_s = diameter of steel hoops (spiral).

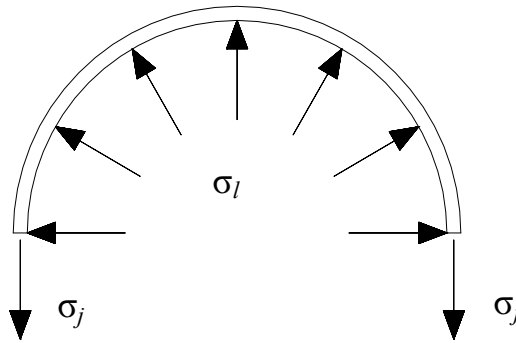

Fig. 6-3: Lateral confining pressure exerted by the jacket.

For the case of concrete cylinders confined with FRP reinforcement, with fibres circumferentially aligned and covering the total concrete surface, the lateral confining pressure σ_ℓ can be evaluated in analogy to eq. (6-1) as:

$$\sigma_\ell = \frac{1}{2} \rho_j \sigma_j = \frac{1}{2} \rho_j E_j \varepsilon_{j=\ell} \quad \text{with} \quad \rho_j = \frac{4 t_j}{d_j} \quad (6-2 a)$$

with ρ_j = volumetric ratio of FRP jacket, σ_j = stress in FRP jacket, E_j = the modulus of the composite material of the jacket, $\varepsilon_{j=\ell}$ = circumferential strain in FRP jacket (taken equal to the lateral strain in concrete), t_j = FRP jacket thickness and d_j = diameter of FRP jacket. It should be noted that $k_e = 1$ as the cylinder is totally wrapped.

The lateral confining pressure σ_ℓ exerted by the confining jacket is computed based on its current stress $\sigma_j = E_j \varepsilon_j \leq f_j = E_j \varepsilon_{ju}$, whilst the maximum lateral confinement f_ℓ is provided for $\varepsilon_j = \varepsilon_{ju} = \text{FRP jacket effective ultimate circumferential strain}$:

$$f_\ell = \frac{1}{2} \rho_j E_j \varepsilon_{ju} \quad (6-2 \text{ b})$$

6.2.4 Stress-strain model of FRP-confined concrete

Several relations exist to describe the stress-strain relationships for concrete under multiaxial states of stress (Chen et al. 1981, CEB 1983, Mander et al. 1988, CEB-FIP 1991). The model of Mander, based on that by Popovics (1973) in which the peak stress is computed based on the confining stress, proved to be the most efficient when only the uniaxial response is of concern. In recent years, researchers have attempted to extend this model to predict the behaviour of concrete including the effect of confinement provided by elastic FRP jackets. A major obstacle is that the Popovics-Mander model is based on a *constant* value of the confining pressure throughout the loading history. In reality, passive confinement increases as concrete expands laterally, its amount depending on the stress-strain law of the confining device. For the case of steel transverse reinforcement, the constant confining pressure assumption is realistic when the steel is yielding. Therefore, Mander's model correctly represents the behaviour of steel-confined concrete (except for the initial phase when steel is still elastic). Conversely, FRP is elastic until failure, and the inward pressure continuously increases, so that this assumption is not appropriate.

In the literature, several models have been proposed for FRP confined concrete, which try to take into account the specific behaviour of FRP confinement. In the model developed by Spoelstra and Monti (1999), to deal with the increasing confining action, an incremental-iterative calculation is proposed, which combines the above-mentioned Popovics-Mander equations with a model expressing the circumferential strain as a function of the axial strain (Pantazopoulou and Mills 1995). An incremental approach is also followed by Saafi et al. (1999), which can be solved without iterations. The model considers an initial region of the stress-strain law, similar to that of unconfined concrete, since lateral expansion of the concrete is small. The second region, with FRP confinement fully activated, is calculated based on the confinement model by Richart et al. (1929), whereas model coefficients are experimentally calibrated. Yet another approach is suggested by Samaan et al. (1998). This model (a non-normalized version of the well-known Menegotto-Pinto equation for steel, but with regression-based parameters) is based on the observation that the dilation rate (change of circumferential strain with respect to the axial strain) of FRP-confined concrete approaches an asymptotic value. Hence, it is suggested to model the restraining action of the FRP by taking into account the ultimate confining pressure and the stiffness of the FRP wrapping only, without further need for an incremental approach. Model parameters of the stress-strain relationship need to be experimentally calibrated.

Although the models mentioned above take into account the specific behaviour of FRP confinement, each of them has some advantages and disadvantages. Being an engineering model, the one proposed by Samaan et al. (1998) is the simplest and most attractive, but depends heavily on the experimental calibration conducted by the authors. Matthys (2000), based on experimental and analytical work, argued that this model, as well as the model by Saafi et al. (1999), may need more consideration and further verification against experimental data on large-scale specimens, and that, among the three models, the one by Spoelstra and Monti is the most complex to calculate. Nevertheless, the latter model appears most versatile and accurate (Matthys 2000) (although further verification against experimental data would be

welcome) and, what is more important, it can be easily extended to deal with cyclic loading. This model is presented in the following.

The Spoelstra-Monti model is based on the formula (Popovics 1973):

$$\sigma_c = \frac{f_{cc} \cdot x \cdot r}{r - 1 + x^r} \quad (6-3)$$

where

$$x = \frac{\varepsilon_c}{\varepsilon_{cc}} \quad \varepsilon_{cc} = \varepsilon_{co} \left[1 + 5 \left(\frac{f_{cc}}{f_{co}} - 1 \right) \right] \quad r = \frac{E_c}{E_c - E_{sec}} \quad E_{sec} = \frac{f_{cc}}{\varepsilon_{cc}} \quad (6-4)$$

where ε_{cc} = compressive strain at confined peak strength f_{cc} . The confined peak strength f_{cc} is expressed in terms of a *constant* (throughout the response) effective confining pressure $\sigma_t \leq f_t$ with an equation (Mander et al. 1988) that has been extensively tested against experimental data:

$$\frac{f_{cc}(\sigma_t)}{f_{co}} = 2.254 \sqrt{1 + 7.94 \frac{\sigma_t}{f_{co}}} - 2 \frac{\sigma_t}{f_{co}} - 1.254 \quad (6-5)$$

To account for the peculiar behaviour of FRP, the following approach is taken (Spoelstra and Monti 1999). The uniaxial stress response σ_c of plain concrete under compressive axial strain ε_c is described as (Pantazopoulou and Mills 1995):

$$\sigma_c = E_{sec}(\varepsilon_\ell) \cdot \varepsilon_c \quad (6-6 a)$$

$$E_{sec}(\varepsilon_\ell) = E_c \frac{1}{1 + \beta \varepsilon_A} = E_c \frac{1}{1 + 2\beta \varepsilon_\ell} \quad (6-6 b)$$

Note that the area strain ε_A is taken as a measure of the internal damage from cracking, which reduces the secant modulus E_{sec} , starting from the initial tangent modulus E_c . The constant β (here, the reciprocal of that given in the original paper by Pantazopoulou and Mills 1995) is a property of concrete, as discussed below. Note that in eq. (6-6 b) the assumption of radial symmetry ($\varepsilon_A = 2\varepsilon_\ell$) is adopted, which allows to point out the dependence on the lateral strain ε_ℓ . Note also that the sign convention is: compressive ε_c and σ_c are negative, while dilating ε_A and ε_ℓ are positive.

Equations (6-6 a, b) are merged into a single equation:

$$\varepsilon_\ell(\varepsilon_c, \sigma_\ell) = \frac{E_c \varepsilon_c - \sigma_c(\varepsilon_c, \sigma_\ell)}{2\beta \sigma_c(\varepsilon_c, \sigma_\ell)} \quad (6-7)$$

where the dependence of the quantities σ_c and ε_ℓ on the current strain ε_c and the current confining pressure σ_t is rendered explicitly. The constant β is a property of concrete:

$$\beta = \frac{5700}{\sqrt{|f_{co}|}} - 500 \quad (6-8)$$

evaluated as a function of the unconfined concrete strength f_{co} (in MPa).

Once ε_l is computed from eq. (6-7), the strain ε_j in the confining jacket can be found (e.g., in axially loaded concrete cylinders it is simply: $\varepsilon_j = \varepsilon_l$), along with its current stress $\sigma_j = E_j \varepsilon_j$. This updated value of σ_l can be used for a new estimate of ε_l through eq. (6-7), giving rise to an iterative procedure (Fig. 6-4) until σ_l converges to the correct value. The whole procedure is repeated for each ε_c , over the complete stress-strain curve. The resulting curve can be regarded as a curve crossing a family of Popovics curves, each one pertaining to the level of confining pressure, computed with the Mander equation, corresponding to the current lateral strain, determined according to Pantazopoulou and Mills (1995). The stress-strain characteristics of the confining mechanism are explicitly accounted for, while the lateral strain of concrete is implicitly obtained through the iterative procedure. All numerical tests have shown that convergence is very fast.

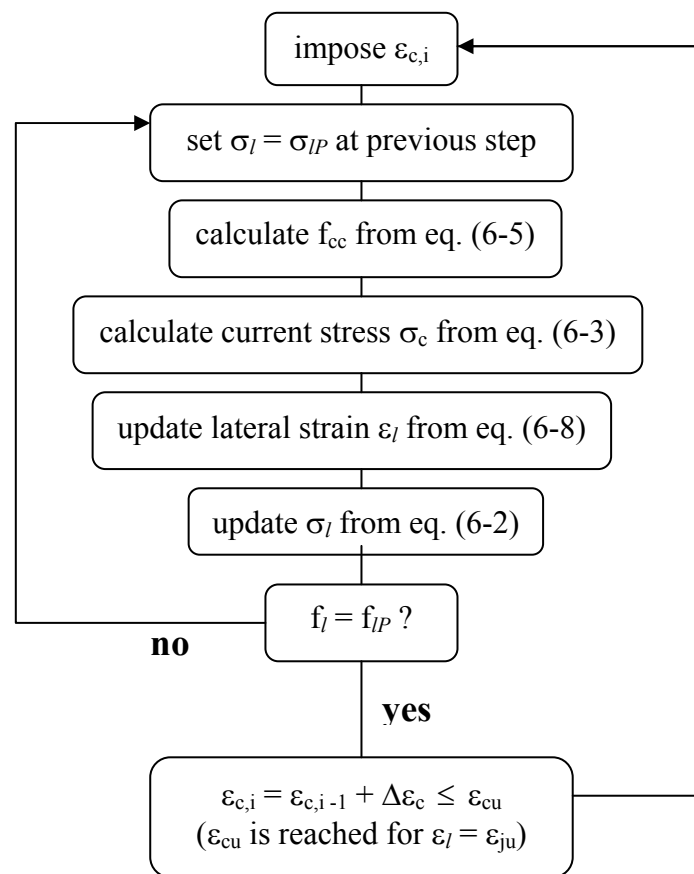

Fig. 6-4: Iterative procedure of Spoelstra and Monti (1999) model.

The response of an FRP-wrapped concrete specimen obtained with this model can be seen in Fig. 6-5, along with a comparison with steel-confined concrete.

In Fig. 6-5 a the axial stress versus axial strain is shown: steel and CFRP start with almost the same slope, but after steel yields at 2.5 normalized axial strains, it departs towards higher axial strains. GFRP starts with the same slope until the unconfined concrete strength is reached; after that point GFRP has a lower slope leading to higher axial strains.

In Fig. 6-5 b the lateral strain versus axial strain relation is shown. It can be observed that the slope of the branches depends on the type of the confining device. GFRP starts with a higher slope (meaning that concrete has a higher initial lateral dilation), which however

remains constant until the jacket fails. CFRP reduces the initial lateral strain, but its effectiveness has a shorter duration, due to its lower extensional ultimate strain ϵ_{ju} .

In Fig. 6-5 c the dilation rate is expressed as a function of the axial strain. The dilation rate $\mu = \Delta\epsilon_\ell / \Delta\epsilon_c$ is defined as the rate of increase of the lateral strain $\Delta\epsilon_\ell$ to the corresponding axial strain increment $\Delta\epsilon_c$. It is seen that when steel yields a discontinuity occurs, due to the abrupt change in modulus; after this, the dilation rate increases indefinitely. On the other hand, for the two FRP, the dilation rate constantly decreases towards an asymptotic value. Note that the position of the point where the confinement action starts becoming effective (that is, when the branches depart from the unconfined one) depends on the stiffness of the confining device: the GFRP-confined concrete departs later than the other two. This is the point where a sufficient lateral pressure develops that prevents the lateral dilation of concrete from increasing unrestrained.

In Fig. 6-5 d, it is interesting to observe from the volume strain versus axial strain curve that for the CFRP jacket the volumetric strain first decreases, as expected, then reverts to zero and beyond a certain level of axial strain the ever increasing confinement pressure curtails the volumetric expansion and inverts its direction.

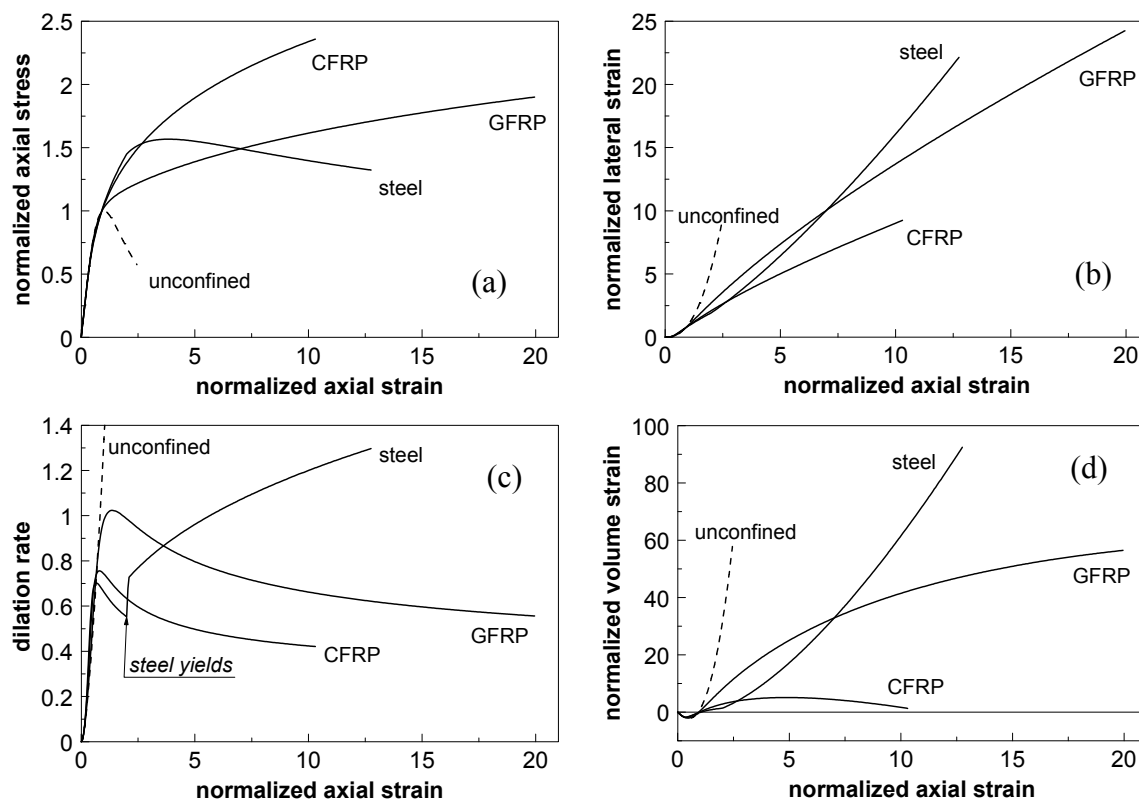

Fig. 6-5: Modeling of behaviour of concrete confined with steel, CFRP and GFRP: (a) axial stress versus axial strain; (b) lateral strain versus axial strain; (c) dilation rate versus axial strain; and (d) volume strain versus axial strain.

6.2.5 Predictive equations of FRP-confined concrete properties

Collapse of FRP-wrapped concrete specimen is identified when the condition:

$$\epsilon_\ell = \epsilon_{ju} \tag{6-9}$$

is satisfied, that is, when the lateral strain of concrete reaches the effective ultimate or allowable strain of the FRP material and the jacket fails (no progressive ply failure is considered). The value of the ultimate strength and strain of the FRP-confined concrete can be predicted through the model mentioned in the previous section. However, for design purposes simplified explicit expressions are given in this section. For the case of steel-confined concrete, the ultimate strain ε_{cu} of concrete is predicted through an energy-balance method (Mander et al. 1988), in which it is assumed that the increase in strain energy capacity of compressed concrete due to confinement is provided by the confining device strain energy capacity. The ultimate strain energy capacity of the confining device is given by the area under the stress-strain curve times the volumetric ratio. When this is attained, the confining device collapses and the corresponding concrete strain is taken as the ultimate strain. However, it has been commented (Mirmiran et al. 1996) that the energy-balance method cannot be extended to the case of FRP confinement. To this aim, practical formulae to evaluate the ultimate compressive strength and strain for concrete confined with FRP have been developed (Seible et al. 1995b, Spoelstra and Monti 1999, Matthys 2000), which should be useful for design practice. Alternative to these simple regression-based models, an “exact” closed-form expression can be obtained, based on Section 6.2.4.

6.2.5.1 “Exact” predictive equations

Irrespective of the complete stress-strain response, the ultimate state can be derived by considering that the strain-stress coordinates at ultimate can be directly known from the confinement pressure exerted by the jacket at ultimate (Spoelstra and Monti 1999).

Following Fig. 6-6 note that:

1. The ultimate confinement pressure is given by:

$$f_\ell = \frac{1}{2} \rho_j f_j = \frac{2 t_j f_j}{d_j} \quad (6-10)$$

2. The parameters of the Mander confinement model corresponding to f_t are then:

$$f_{cc} = f_{co} \left(2.254 \sqrt{1 + 7.94 \frac{f_\ell}{f_{co}}} - 2 \frac{f_\ell}{f_{co}} - 1.254 \right) \quad \varepsilon_{cc} = \varepsilon_{co} \left[1 + 5 \cdot \left(\frac{f_{cc}}{f_{co}} - 1 \right) \right] \quad (6-11)$$

3. The secant modulus at ultimate $E_{sec,u}$ is:

$$E_{sec,u} = \frac{E_c}{1 + 2\beta \varepsilon_{ju}} = \frac{E_c}{1 + 2\beta f_j / E_j} \quad (6-12)$$

4. The intersection of the straight line with slope $E_{sec,u}$ in Fig. 6-6 with the Popovics curve at ultimate gives the sought compressive strain and stress in concrete at ultimate:

$$\varepsilon_{cu} = \varepsilon_{cc} \left[\frac{E_{cc} (E_c - E_{sec,u})}{E_{sec,u} (E_c - E_{cc})} \right]^{1 - E_{cc}/E_c} \quad f_{cu} = E_{sec,u} \varepsilon_{cu} \quad (6-13)$$

where $E_{cc} = f_{cc} / \varepsilon_{cc}$.

5. Substituting eq. (6-12) into eq. (6-13) the above become:

$$\varepsilon_{cu} = \varepsilon_{cc} \left(\frac{2\beta \varepsilon_{ju} E_{cc}}{E_c - E_{cc}} \right)^{1-E_{cc}/E_c} \quad f_{cu} = \frac{E_c \varepsilon_{cu}}{1 + 2\beta \varepsilon_{ju}} \quad (6-14)$$

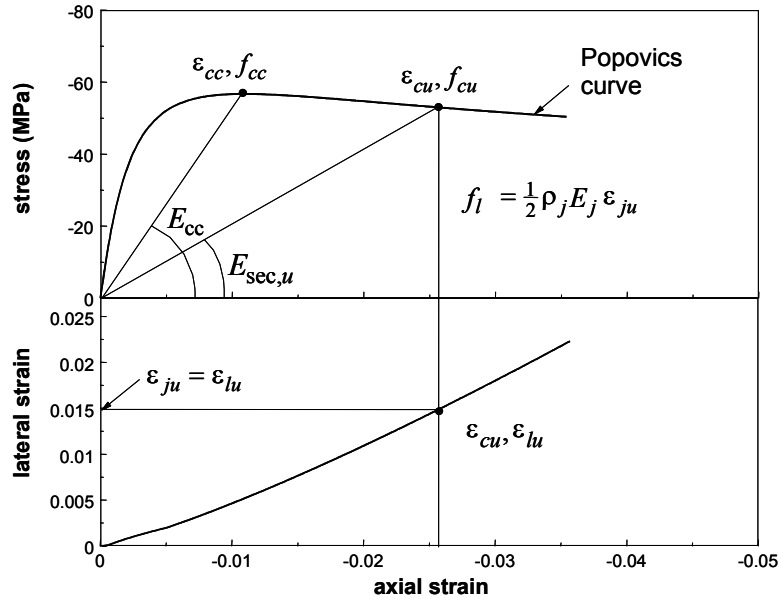

Fig. 6-6: Calculation procedure for ultimate compressive stress and strain.

6.2.5.2 Approximate predictive equations

Practical formulae by Seible et al. (1995b)

The ultimate strain ε_{cu} can be computed through a formula experimentally derived for concrete and adapted to the case of FRP-confined concrete (Seible et al. 1995b):

$$\varepsilon_{cu} = 0.004 + \frac{2.5 \rho_j f_j \varepsilon_{ju}}{f_{cc}} \quad (6-15)$$

where ρ_j is the jacket volumetric ratio; and f_j , ε_{ju} = FRP jacket strength and effective ultimate strain, respectively. The confined concrete peak strength f_{cc} is computed as in eq. (6-11).

Practical formulae by Spoelstra and Monti (1999)

The following formulae are based on the observation that in experimental tests both the ultimate strength and strain have a direct dependence on the ultimate strain of the confining member ε_{ju} , the maximum confinement pressure f_ℓ , and the concrete modulus E_c , while they have an inverse dependence on the unconfined concrete strength f_{co} . Through regression analyses, the following two predictive equations were obtained:

$$f_{cu} = f_{co} \left(0.2 + 3\sqrt{f_\ell} \right) \quad (6-16)$$

$$\varepsilon_{cu} = \varepsilon_{co} \left(2 + 1.25 \bar{E}_c \varepsilon_{ju} \sqrt{\bar{f}_\ell} \right) \quad (6-17)$$

where the normalised values of the maximum confining stress and of the concrete tangent modulus are:

$$\bar{f}_\ell = \frac{f_\ell}{f_{co}} \quad \text{and} \quad \bar{E}_c = \frac{E_c}{f_{co}} \quad (6-18)$$

Note that for no confinement ($f_\ell = 0$) the resulting strain and strength at ultimate are those of an unconfined concrete with $\varepsilon_{cu} = 0.004$ (with $\varepsilon_{co} = 0.002$) and f_{cu} equals to 20% of the unconfined strength, which is the value usually adopted for it.

In all the above equations for the ultimate strength prediction, there are cases where, for low amounts of FRP wrapping reinforcement or low efficiency (square or rectangular cross-sections, partial wrapping), test results and analytical modelling have shown that the stress-strain behaviour may be characterized by a decreasing (post-peak) branch at ultimate. In these cases, the confining pressure results in an almost negligible strength increase, so that the confined concrete strength f_{cc} can be taken as practically coincident to the unconfined one f_{co} .

6.3 Confinement of columns

6.3.1 General

Confinement of reinforced concrete columns (or similar elements, like chimneys) significantly enhances the performance under axial load, bending and shear, because of the increase in concrete compressive strength, the increase in ductility, the increase in shear strength and the higher resistance against buckling of the steel reinforcement in compression.

The confinement of columns is achieved by means of internal lateral reinforcement (hoop or closed stirrups) or by external reinforcement (steel or FRP jackets). In the latter case, the confinement reinforcement can be provided either through external strengthening of existing columns, or as formwork that acts as structural reinforcement after construction of the columns.

The main objectives of confinement are: (a) to prevent the concrete cover from spalling, (b) to provide lateral support to the longitudinal reinforcement and (c) to enhance concrete strength and deformation capacities. In the case of circular columns, these goals can be achieved by applying external FRP jackets, either continuously all over the surface or discontinuously as strips. In the case of rectangular columns, the confinement can be provided with rectangular-shaped reinforcement, with corners rounded before application (the radius is about 15 to 25 mm, depending on the specifications given by the FRP jacket supplier). Rectangular confining reinforcement is less efficient as the confinement action is mostly located at the corners and a significant jacket thickness needs to be used between corners to restrain lateral dilation and column bar buckling. An alternative approach is to enclose the rectangular column within an externally cast circular or oval shape that provides the appropriate shape for the jacket.

Carbon fibres are preferred if strength increase is sought, glass (or aramid) fibres if a ductility increase is sought instead. The FRP jacket can consist of active or passive layers, or a combination of both. Like steel jackets, passive FRP jackets provide a passive lateral confining pressure. When (prestressed) active jackets are used, the lateral confining pressure is primarily provided by the active pressure, rather than the passive pressure resulting from column lateral expansion. The latter influence will increase confinement, but is not essential.

6.3.2 Effective lateral confining pressure

Depending on column shape and strengthening lay-out, a non-uniform confining stress distribution is obtained. Next, the following cases are examined: (1) Fully wrapped cylindrical specimens with fibres perpendicular to longitudinal axis, (2) Influence of partial wrapping, (3) Influence of fibre orientation, and (4) Influence of column shape.

6.3.2.1 Fully wrapped cylindrical specimens with fibres perpendicular to longitudinal axis

For uniaxially loaded cylindrical concrete specimens confined with FRP reinforcement, with fibres circumferentially aligned and covering the total concrete surface, the lateral confining pressure may be found by considering Fig. 6.7 a. Assuming uniform tension in the FRP, a uniform lateral pressure is exerted on the concrete core.

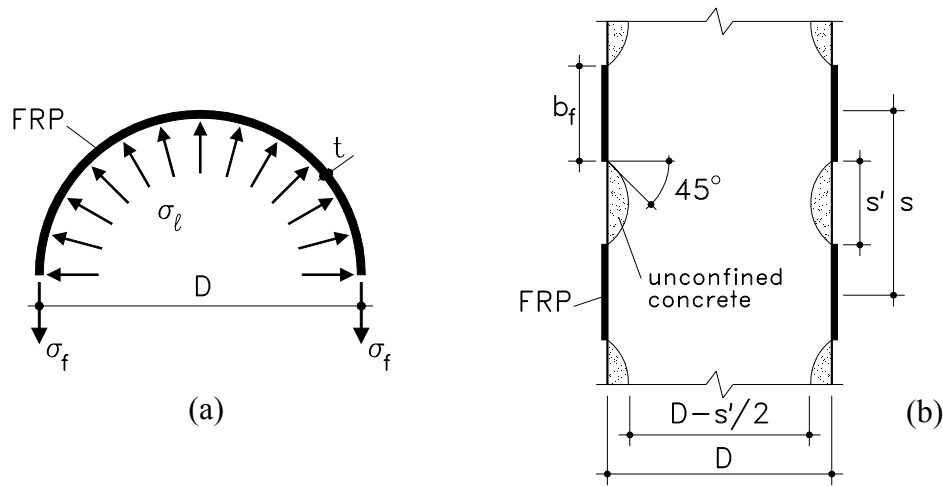

Fig. 6-7: Confining pressure exerted by the FRP.

The lateral confining pressure σ_ℓ can be expressed as a function of the current stress σ_j in the FRP jacket [see also eq. (6-2 b)] can be rewritten as:

$$\sigma_\ell = K_{\text{conf}} \varepsilon_\ell \quad \text{with} \quad K_{\text{conf}} = \frac{1}{2} \rho_j E_j \quad (6-19)$$

where K_{conf} = stiffness of the FRP confinement, ε_ℓ = circumferential strain of the concrete, equal to the strain ε_j in the FRP jacket, ρ_j = volumetric ratio of the FRP jacket and E_j = modulus of the FRP jacket. Hence, the lateral confining pressure σ_ℓ exerted by the FRP jacket is calculated based on its current stress $\sigma_j = E_j \varepsilon_j \leq f_j$. The maximum lateral confinement pressure f_ℓ is obtained as:

$$f_\ell = \frac{1}{2} \rho_j E_j \varepsilon_{ju} \quad (6-20)$$

with ε_{ju} the effective failure strain of the FRP wrapping reinforcement as discussed in Section 6.2.2.

6.3.2.2 Influence of partial wrapping

If the concrete is partially wrapped, less efficiency is obtained as both confined and unconfined zones exist (Fig. 6-7 b). In this case, the effective lateral confining pressure is obtained from eq. (6-22) by introducing a confinement effectiveness coefficient $k_e \leq 1$:

$$K_{\text{conf}} = \frac{1}{2} k_e \rho_j E_j \quad (6-21)$$

The effectiveness coefficient is obtained by considering that the transverse pressure from the confining device is only effective where the confining pressure has fully developed due to arching action. As illustrated in Fig. 6-7, the arching effect is assumed to be described by a parabola with initial slope of 45° . In between two subsequent FRP wraps, the area of effectively confined concrete core A_e is:

$$A_e = \frac{\pi}{4} \left(D - \frac{s'}{2} \right)^2 \quad (6-22)$$

where $s' = s - b_f$ is the clear spacing between the FRP wraps. The confinement effectiveness coefficient k_e is then obtained by considering the ratio A_e / A_c , with $A_c = A_g - A_s$ the area of concrete (gross cross-sectional area minus area of longitudinal steel reinforcement):

$$k_e = \frac{\left(1 - \frac{s'}{2D} \right)^2}{1 - \rho_{\text{sg}}} \approx \left(1 - \frac{s'}{2D} \right)^2 \quad (6-23)$$

where $\rho_{\text{sg}} = A_s / A_g$ is the reinforcement ratio of the longitudinal steel reinforcement with respect to the gross cross-sectional area.

6.3.2.3 Influence of fibre orientation

If the fibres are helically applied, the fibre alignment is less efficient to restrain the lateral expansion of the concrete. Similarly to the previous section, this effect can be considered by introducing a corresponding confinement effectiveness coefficient. Assuming a uniform tension force N_f in the FRP, the confinement pressure exerted by the helical FRP wrapping reinforcement is given by:

$$\sigma_{\ell, h} = \frac{N_f}{b_f R} \quad (6-24)$$

where R is the curvature of the helix, given as:

$$R \approx \frac{k^2 + r^2}{r} \quad (6-25)$$

with $k = p/2\pi$, p being the helix pitch and r the radius. In a similar way, the confinement pressure per unit width exerted by circular FRP wrapping reinforcement is obtained as:

$$\sigma_{\ell,c} = \frac{N_f}{b_f r} \quad (6-26)$$

Based on eq. (6-24)-(6-26), the confinement effectiveness coefficient k_e can be defined as:

$$k_e = \frac{\sigma_{\ell,h}}{\sigma_{\ell,c}} = \left[1 + \left(\frac{p}{\pi D} \right)^2 \right]^{-1} \quad (6-27)$$

6.3.2.4 Influence of column shape

For a square or rectangular section wrapped with FRP (Fig. 6-8) and with corners rounded with a radius r_c , the parabolic arching action is again assumed for the concrete core where the confining pressure is fully developed. Unlike a circular section, for which the concrete core is fully confined, a large part of the cross-section remains unconfined.

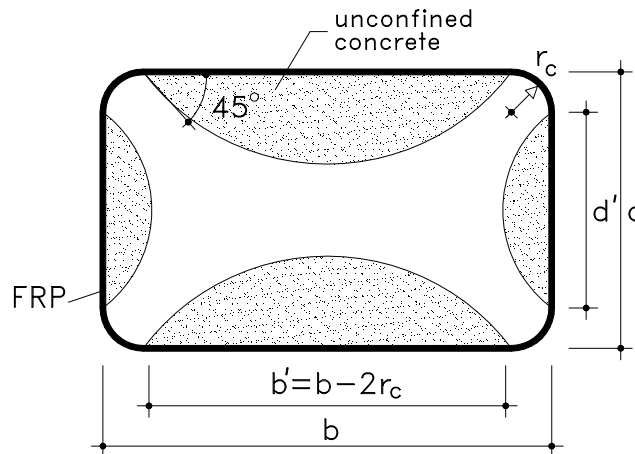

Fig. 6-8: Effectively confined core for non-circular sections.

Taking the sum of the different parabolas, the total plan area of unconfined concrete is obtained as:

$$A_u = \sum_{i=1}^4 \frac{(w'_i)^2}{6} = \frac{b'^2 + d'^2}{3} \quad (6-28)$$

where w'_i is the clear distance between the rounded corners. Considering the ratio $(A_c - A_u)/A_c$, the confinement effectiveness coefficient k_e is given by:

$$k_e = 1 - \frac{b'^2 + d'^2}{3A_g(1 - \rho_{sg})} \quad (6-29)$$

Similar to eq. (6-19) (circular section), the lateral confining pressures induced by the FRP wrapping reinforcement on a square or rectangular cross-section are given as:

$$\begin{aligned}\sigma_{\ell x} &= K_{\text{confx}} \varepsilon_{ju} & \text{with} & \quad K_{\text{confx}} = \rho_{jx} k_e E_j \\ \sigma_{\ell y} &= K_{\text{confy}} \varepsilon_{ju} & \text{with} & \quad K_{\text{confy}} = \rho_{jy} k_e E_j\end{aligned}\quad (6-30)$$

where the ratios ρ_{jx} and ρ_{jy} represent the volumetric ratio of transverse confining reinforcement in the x and y direction and are given by:

$$\rho_{jx} = \frac{2b_f t_j}{s d} \quad \text{and} \quad \rho_{jy} = \frac{2b_f t_j}{s b} \quad (6-31)$$

The above is applicable in those cases where section ovalisation is impractical. In the case of rectangular columns subsequently ovalised, the oval jacket has a changing radius of curvature in the different loading directions. An equivalent circular column diameter can be derived by taking the average of the oval principal radii, so that the jacket thickness calculations can follow those outlined for circular columns. In these cases, the effective lateral confining pressure $\sigma_{\ell, \text{eff}}$ exerted by the confining device equals the lateral confining pressure σ_{ℓ} given by eq. (6-2 a), and similarly the maximum effective lateral confining pressure $f_{\ell, \text{eff}}$ equals f_{ℓ} given by eq. (6-2 b).

6.3.3 Load-carrying capacity

Depending on the loading conditions (axial loading, shear and bending) the capacity of the columns should be calculated according to appropriate models as given by EC2 and MC90. The capacity of the section can be computed based on the ultimate strength as given in eq. (6-16). For modelling the FRP-confined concrete, reference is made to the above sections. With regard to flexural and shear strengthening reference is made to Chapters 4 and 5, respectively. Confinement in seismic regions for ductility increase by means of FRP wrapping is covered in Section 6.4.

6.3.4 Buckling

According to Seible et al. (1995), to ensure that column bar buckling in the plastic hinge zone does not control the flexural failure model, additional checks on the transverse reinforcement ratio of the jacket need to be performed, particularly for slender columns where $M/(VD) > 4$ (with M and V being the maximum column moment and shear, respectively and D the column diameter). The required composite jacket thickness is inversely proportional to the jacket modulus E_j in the hoop direction and directly proportional to the column diameter.

6.4 Use of confinement to increase ductility in seismic regions

In seismic regions, columns (or bridge piers) built in the past followed the design criteria of old codes, which favoured the strength aspects while neglecting the importance that ductility has in ensuring stability of the response in the post-elastic range. Most of those structural elements are inadequate to meet the more stringent requirements imposed in the new generation of codes are now in need for upgrading. A summary of methods for

improving plastic hinge behaviour through FRP confinement as given by Triantafillou (2001) is given next.

The method of selecting the jacket thickness for a target displacement ductility factor μ_{Δ} is a relatively straightforward procedure: First the equivalent plastic hinge length L_p for a given column is calculated based on the yield stress and diameter of longitudinal rebars. From L_p and μ_{Δ} the curvature ductility factor $\mu_{\Phi} = \Phi_u / \Phi_y$ is established. The yield curvature Φ_y may be found from moment-curvature analysis of the cross section, whereas the maximum required curvature Φ_u may be obtained (again from section analysis) in terms of the ultimate concrete strain. Hence the required value for ϵ_{cu} can be established and an appropriate confinement model (one of the models described in Section 6.2.5) can be used to solve for the required FRP thickness.

Japanese researchers (Mutsuyoshi et al. 1999) have followed a different approach towards assessing the displacement ductility factor of FRP-confined columns. According to this approach, the ductility factor may be related to the shear capacity V_u , and to the moment capacity M_u of the member after retrofit, according to empirical equations of the type:

$$\mu_{\Delta} = \alpha + \beta(V_u a / M_u) \leq 10 \quad (6-32)$$

where a is the shear span and the constants α , β depend on the type (that is the deformability) of the fibres.

An alternative design equation has been proposed (Monti et al. 2001) for the ductility upgrade of circular columns having diameter D . The equation stems from the definition of a *section upgrading index* $I_{sec} = \delta_{sec}^{tar} / \delta_{sec}^{ava}$, representing the ratio of the target sectional ductility (to be obtained through upgrading) and the initially available sectional ductility (evaluated through assessing the existing section). The sectional curvature ductility factor μ_{Φ} can be obtained from the displacement ductility factor μ_{Δ} in analogy to what was explained above. The design equation yields the jacket thickness t_j , expressed in terms of the mechanical characteristics of the FRP jacket (ultimate strength f_j and ultimate strain ϵ_{ju}):

$$t_j = 0.2 D I_{sec}^2 \cdot \frac{f_{cc}^{ava}}{f_j} \cdot \frac{\epsilon_{cu}^{ava 2}}{\sqrt{\epsilon_{ju}^3}} \quad (6-33)$$

and also expressed in terms of two assessed properties of the column to be upgraded: (1) the (steel-hoops-) confined concrete strength f_{cc}^{ava} is calculated according to Mander et al. (1988):

$$f_{cc}^{ava} = f_{co} \left(2.254 \sqrt{1 + 7.94 \bar{f}_{\ell}} - 2 \bar{f}_{\ell} - 1.254 \right) \quad (6-34)$$

where $\bar{f}_{\ell} = f_{\ell} / f_{co}$ = normalized confining pressure, with:

$$f_{\ell} = \frac{1}{2} k_e \rho_{st} f_y \quad (6-35)$$

where k_e = tie-by-tie arching-effect coefficient (usually 0.8), and ρ_{st} is the volumetric ratio of the (existing) steel hoops having yield strength f_y ; (2) The concrete ultimate strain ϵ_{cu}^{ava} , when only the steel hoops confinement is present, can be computed through a widely accepted experimentally-derived formula (Seible et al. 1995b):

$$\varepsilon_{cu}^{ava} = 0.004 + \frac{1.4 \rho_{st} f_y \varepsilon_{su}}{f_{cc}} \quad (6-36)$$

where ε_{su} = steel hoops ultimate strain.

6.5 FRP as formwork and structural reinforcement

Although Chapter 6 basically discusses the use of FRP wrapping reinforcement as a strengthening technique for existing concrete members, this technique is also of interest for new structures.

In situ or precast columns can be realised using concrete-filled prefabricated filament-wound FRP tubes. In this construction technique, also called *composite column casings*, an FRP tube is used as a permanent formwork, which allows reducing the time and cost of erection. It acts also as structural reinforcement, enabling an enhancement in both strength and ductility of the compressed member.

For more information on this subject reference is made to Mirmiran et al. (1996), Caltrans (1997), Lillistone and Jolly (2000).

7 Detailing rules

7.1 General

The quantity of bonded FRP reinforcement is calculated according to the models described in the previous chapters. Detailing rules give practical information on the location, arrangement and limitations for the FRP reinforcement required by considerations such as minimum ductility, functional requirements, adequate anchorage, applicability of calculation models, practical durability measures, environmental conditions, etc.

Compared to other aspects of the EBR strengthening method (e.g. design for bending), requirements for detailing are much less supported by available test results. Nevertheless detailing rules are important and if not attended to may lead to premature failure of the strengthened structure. This is an aspect where future research is definitely needed. Most of the existing design specifications on EBR strengthening do not contain any or contain a very limited amount of detailing rules.

7.2 Detailing with respect to strengthening lay-out

7.2.1 Flexural strengthening

Flexural strengthening is provided by axially orientated fabrics of pultruded strips or cured in-situ fabrics bonded to the top or bottom faces of the member or even to the sides (see Fig. 7-1).

In the anchorage zones no additional transverse reinforcement is required if adequate anchorage is provided by bond stresses and debonding is resisted by concrete tensile stresses.

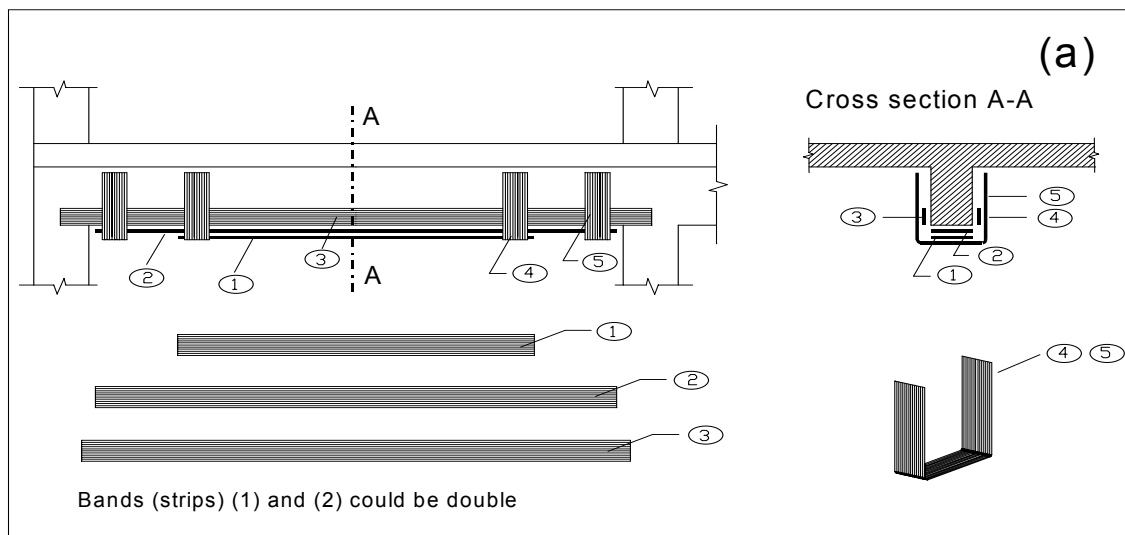

Fig. 7-1: Flexural reinforcement with possible shear anchorages.

7.2.1.1 General recommendations

The following recommendations should apply (Deutsches Institut für Bautechnik 1998):

- Maximum spacing $s_{f,max}$ between strips:

$$\begin{aligned} s_{f,\max} &\leq 0.2 \ell \quad (\ell = \text{span length}) \\ &\leq 5 h \quad (h = \text{total depth}) \\ &\leq 0.4 \ell_c \quad (\ell_c = \text{length of cantilever}) \end{aligned}$$

- Minimum distance to the edge of the beam should equal the concrete cover of the internal reinforcement.
- Lap joints of strips should only be provided in sections where the maximum tensile force in the EBR does not exceed 60% of the tensile force at ultimate. The lap length should be calculated according to the verification of the end anchorage (see Chapter 4), where f_{ctm} should equal 10 N/mm² (bond strength of the adhesive). Joints are allowed for static loading only. Nevertheless, it is strongly recommended here that lap joints should be avoided; they are absolutely not necessary, because FRP can be delivered in the required length.
- Permissible radii of bends should be given in the product description for the strips. Permissible radii of fabrics need not be specified. However, it is recommended that sharp edges of the section be mechanically rounded before application. In this case, a minimum radius of 30 mm is recommended.
- Crossing of strips is allowed, with bonding in the crossing area.

7.2.1.2 Case of several layers

If several strips are to be applied, it is recommended to apply the one next to the other rather than the one onto the other. In this latter case, more than 3 layers of pultruded strips or 5 layers of cured in-situ fabrics are not recommended to apply unless proved by experimental evidence. In any case, recommendations of the EBR supplier must be followed.

By applying several layers of prestressed strengthening strips, reduction of prestressing due to the successive release of prestressing forces should be considered.

7.2.1.3 Anchorage zone

If strengthening is applied in the span of simply supported beams, the distance between the face of the support and the end of the strip should not exceed 50 mm. In the case of applying strips or fabrics over supports of continuous beams or slabs, the strips or fabrics should be anchored in the compression zone (see Fig. 7-2, refer to Chapter 4 for calculation of the anchorage length).

Anchoring of EBR (especially if the strips are staggered) can be ensured by applying bonded FRP “stirrups” that enclose the longitudinal strips at their ends. The use of such stirrups is strongly recommended. Note that these stirrups are not considered to be the part of the shear reinforcement but are responsible to keep the longitudinal strips in their position and to prevent peeling-off.

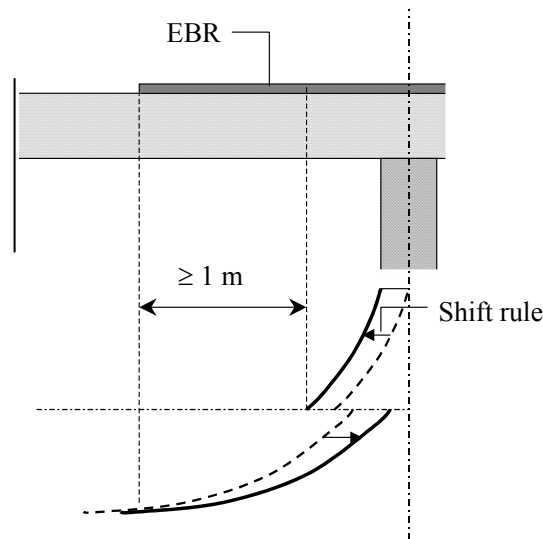

Fig. 7-2: Anchorage above internal supports.

7.2.2 Shear strengthening

Shear strengthening can be provided by:

- factory made L-shaped CFRP strips,
- continuous sheets.

The externally bonded shear reinforcement generally covers four or three sides of the element but in some cases only two sides. Appropriate anchorage is strongly recommended. Practical solutions are given in Fig. 5-2 of Chapter 5. It is important to note that in principle there are two different cases:

1. Proper anchorage of the shear strengthening system [Fig. 5-2 b, eq. (5-4 a, c)],
2. Side or U-shaped shear strengthening system [Fig. 5-2 a, eq. (5-4 b)].

Anchorage failure, debonding failure and FRP fracture are accounted for in design through the effective FRP strains described in Section 5.1 [eq. (5-4 a-c)].

Proper anchorage means a fully wrapped or a system that is properly anchored in the compression zone, as shown in Fig. 7-3 and Fig. 7-4. Where practically possible, it is recommended to use for anchoring the whole height of the compression zone, to guarantee an anchoring as good as possible. FRP strips at the sides of the beam only are not recommended as in this case there is a lack of anchorage in both the compression and tension zone.

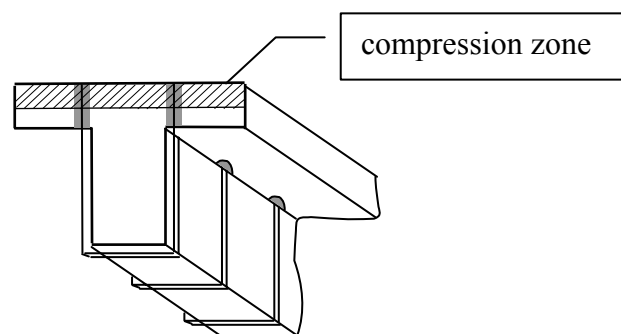

Fig. 7-3: Anchorage in the compression zone.

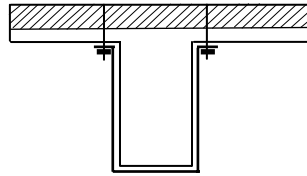

Fig. 7-4: Alternative anchorage in the compression zone.

For the case of insufficient anchorage in the compression zone, the usable height (inner lever arm) has to be reduced, so that the member has a fictitious lower ultimate bending resistance. The principle is illustrated in Fig. 7-5. Until better calculation methods become available, it is recommended to calculate according to this proposal.

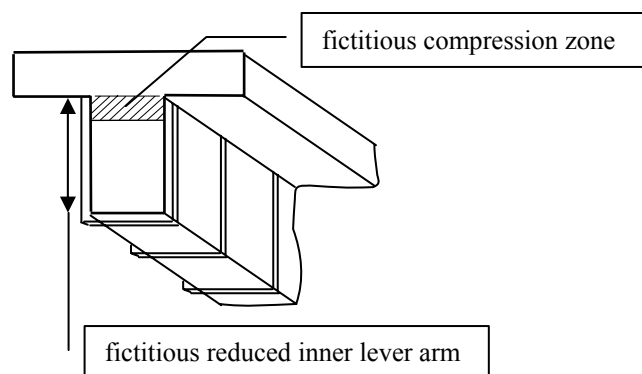

Fig. 7-5: No anchorage: Reduction of the usable height for bending resistance.

7.2.3 Confinement

Compressed members can be effectively confined by externally bonded reinforcement with horizontally or spirally running fibres. The number of superimposed layers (maximum number of layers 20-25 or according to the material supplier's recommendation) is obtained by the analysis described in Chapter 6.

Concerning the application of EBR on rectangular columns or pier walls with large aspect ratio, the EBR does not actually confine the internal concrete structure if just applied to the surface. In order to achieve confinement, the EBR jacket need to be constrained on both sides along the length through the use of dowels or bolts that anchor the jacket to the pre-existing structure, thereby creating shorter distances which are confined between bolts (Karbhari and Seible 1998).

In case of eccentric compressive loads of high magnitude, longitudinally directed fibres can be also applied. These fibres are to be anchored with transverse fibres at the top as well as the bottom of the member.

7.2.4 Humidity and moisture issues

When applying an FRP system, especially in the case of fabrics that can wrap the total surface of the element, water can accumulate at the bond line. Therefore in the case of flexural strengthening of beams or of slabs it is recommended to leave a gap to provide

vapour transfer space. In the case of shear strengthening, a gap every 300 mm should be left exposed. Detailed recommendations can be found in Mack and Holt (1999).

In the case of column strengthening, practice suggests leaving a gap of 30 to 50 mm of concrete unwrapped at the connection between the column and footing and/or cap beam face. Indeed excessive flexural strength in the plastic hinge region due to the contact between the column jacket and the adjacent member may possibly result in undesired moment and shear forces in footings and cap beams during seismic response. A gap is then needed but it also leaves a path for excess water to enter through any irregularities between the FRP and the concrete. Water should be prevented from seeping in between the FRP and the concrete surface by sealing the gap with a water barrier (epoxy resin or paint).

When dealing with humidity and moisture problems, structures to be strengthened can be divided into environmental classes as shown in Table 7-1.

Class 0	Structures located in dry environment with low content of humidity <u>Example</u> : indoor structures
Class 1	Structures that can be subjected to freeze-thaw and minor content of humidity <u>Example</u> : protected outdoor structures
Class 2	Structures located in a humid environment <u>Example</u> : outdoor structures which are not in direct contact with water or subjected to extreme rain (e.g. facades)
Class 3	Structures located in a very humid environment or in direct contact with water or/and environment with high temperature and high humidity <u>Example</u> : part of quay-, bridge- or dam structures in direct contact with water

Table 7-1: Environmental classes (Täljsten 1999 b).

The total surface can be wrapped for classes 0 and 1, special investigations are needed for class 2 and full wrapping should be avoided for class 3.

7.3 Special anchorages

7.3.1 General

Bolts, U-shaped sheets or L-shaped strips (Meier and Bleibler 1999) are recommended at the ends of the EBR to resist concentrations of peel and shear stresses in the region where these stresses exceed the pull-off strength of the concrete times γ_m .

With respect to bolted systems, it is not adequate to drill through the strengthening strip omitting special provisions and merely fixing with a bolt, as drilling holes through unsupported composites severs the unidirectional fibres. As compressive forces can weaken the strip further and as it is not possible for the forces in the strip to be transmitted into the bolt, the end tabs should be designed to take the full force to be anchored. Alternatively, FRP EBR with multidirectional fibres at the location of the bolts can be used in an effective way (Matthys and Blontrock 2000). Bolted systems should be positioned at suitable spacing and anchored in the concrete to a depth beyond the steel reinforcement. The bolts should be

supplied with large washers and tightened up to a specified torque to prevent crushing of the composite materials.

In general, anchoring devices that may influence the integrity of the strengthening system are not recommended. For example, at holes that are necessary when bolts are applied, interlaminar shear failure or splitting of the strip may initiate. Moreover, holes reduce the cross section of the strip.

7.3.2 Device for CFRP strips

The basic scheme of tests made with special anchoring devices for CFRP strips is shown in Fig. 7-6. With this mechanical anchorage a significant increase in anchored tensile force can be obtained. This system can be applied in case of strengthening slabs (where no wrapping is possible), local strengthening and as an anchorage for prestressed strips. A minimum concrete cover of about 20 mm is required.

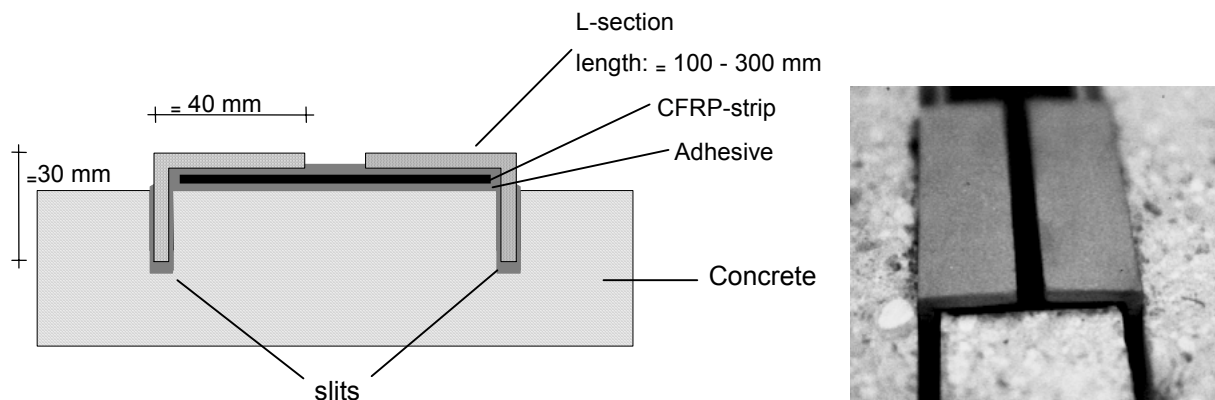

Fig. 7-6: Anchorage for CFRP strips, special anchorage system (Zehetmaier 2000).

7.3.3 Device for sheets

The following patented anchor system (see Fig. 7-7 and 7-8) is a way to bond a composite to a concrete structure in addition to the normal adhesive that is used (Neuner and Falabella 1996). A hole is drilled in the concrete, debris is blown out and epoxy adhesive is applied on the structure. A layer of continuous sheet reinforcement impregnated with an epoxy resin is applied. A glass tow is then forced through the impregnated fabric into the predrilled hole and the ends are splayed outwards in a circle. A final layer of resin-impregnated fabric is applied and allowed to cure.

Concrete blocks made with and without this type of anchors and with glass composite extending outwards from a flush cut edge have been tested. The composite ends were tabbed and shear tests were performed by gripping the tabs and the blocks and pulling apart under tension. The results were concrete failures in both cases with the anchors showing about two times increase in shear strength versus specimens without anchors (Neuner and Falabella 1996).

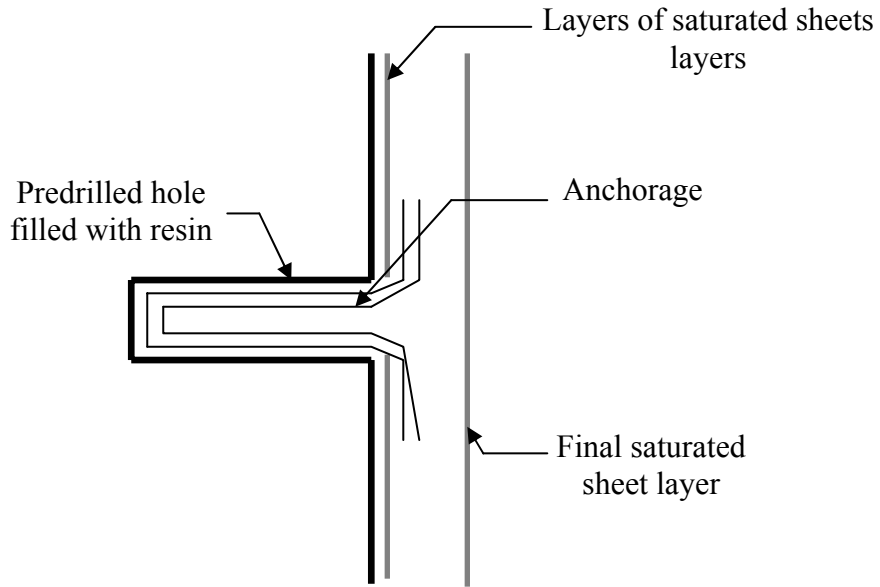

Fig. 7-7: Section of the anchor system.

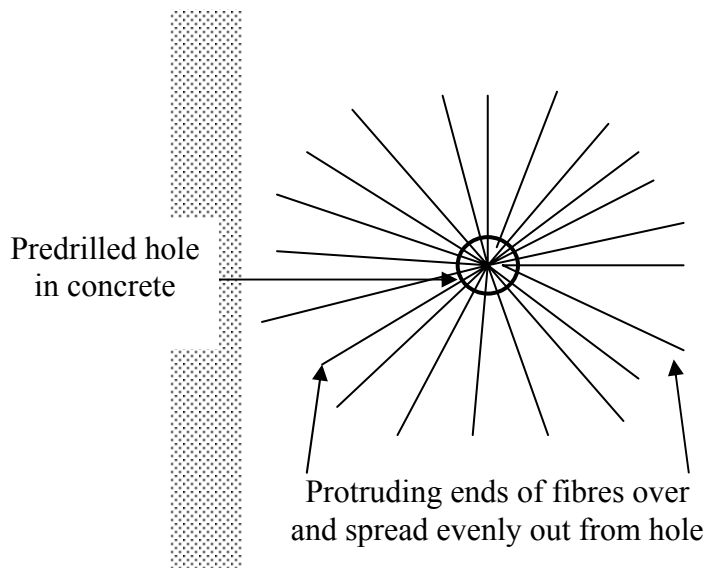

Fig. 7-8: Top view of the anchor system.

8 Practical execution and quality control

8.1 Techniques

The strengthening technique under consideration concerns the use of FRP as structural reinforcement bonded to an existing structure (whereas this document applies for a concrete substrate, application is also possible on masonry, natural stone, wood, aluminium, steel or cast iron), as defined in Chapter 2 “FRP strengthening materials and techniques”. The technique can be used under different conditions and at different locations taking into account all specifications and requirements given hereafter. Rules and practical information on detailing aspects are given in Chapter 7.

8.1.1 Basic technique (manual)

The basic technique of strengthening by means of FRP EBR described here refers to the manual application of FRP reinforcement to an existing member. The bonding is realised through polymerisation of a two-part cold cured bonding agent (normally epoxy-based). All specifications and requirements given in the following sections should be taken into account.

The basic technique involves three acting elements, defined as follows:

1. *Substrate*

The substrate is the material type of the existing structure to which the FRP reinforcement is bonded. Although FRP reinforcement can be applied to different substrates, only a concrete substrate is dealt with in the following sections. The initial conditions of the concrete surface in terms of strength, carbonation, unevenness, imperfections, cracks, type and possible corrosion of internal steel reinforcement, humidity, level of chloride and sulphate ions, etc. should be known.

2. *Adhesive/Resin*

A suitable bonding agent for the FRP reinforcement that meets all requirements specified. Depending on the type of FRP reinforcement the bonding agent not only assures the bond between the substrate and the FRP reinforcement, but also may have to impregnate “wet lay-up” types of FRP EBR.

3. *FRP reinforcement*

The externally bonded FRP reinforcement (FRP EBR) is an advanced composite as defined in Chapter 2.

With respect to the application of the FRP EBR, two major types can be defined. This classification is that used in Chapter 2 to define the different FRP EBR systems:

- *“Prefab” or “pre-cured” strips or laminates*

These FRP strips are provided as fully cured composites, which have their final shape, strength and stiffness. They are mostly available as thin strips or laminates (thickness about 1.0 to 1.5 mm), similar to steel plates. For this type of strip the adhesive provides the bond between the strip and the concrete only.

- *“Wet lay-up (hand lay-up)” or “cured in situ” sheets or fabrics*

These FRP materials are available as “dry fibre”, which means that no resin is inside the FRP before applying, or “prepreg”, having a very small amount of resin already inside the sheet before applying. In the latter case, the amount of resin is not sufficient for polymerisation (other techniques exist, e.g. see Chapter 2, Section 2.3.2.4). For these types of sheets the application of the adhesive is required to both bond the sheet to the concrete and to impregnate the sheet.

An overview of the main characteristics and some typical application aspects of these two types of FRP EBR are given in Table 8-1. More details on the appearance and the characteristics of these FRP EBR types are given in Chapter 2.

	PRE-CURED (PREFAB)	CURED IN SITU (WET LAY-UP)
Shape	Strips or laminates	Sheets or fabrics
Thickness	About 1.0 to 1.5 mm	About 0.1 to 0.5 mm
Use	Simple bonding of the factory made elements with adhesive	Bonding and impregnation of the sheets or fabrics with resin (shaped and cured in-situ)
Typical application aspects	If not pre-shaped only for flat surfaces	Regardless of the shape, sharp corners should be rounded
	Thixotropic adhesive for bonding	Low viscosity resin for bonding and impregnation
	Normally 1 layer, multiple layers possible	Often multiple layers
	Stiffness of strip and use of thixotropic adhesive allow for certain surface unevenness	Often a putty is needed to prevent debonding due to unevenness
	Simple in use, higher quality guarantee (prefab system)	Very flexible in use, needs rigorous quality control
	Quality control (wrong application and bad workmanship = loss of composite action between FRP EBR and substrate/structure, lack of long term integrity of the system, etc.)	

Table 8-1: Main characteristics and typical aspects of FRP EBR (basic technique).

8.1.2 Special techniques

Based on the basic technique, special execution techniques have been developed. Examples and some details of these special techniques are given in Chapter 2 (Section 2.3). The specifications and requirements of these special techniques are not covered in the following sections. They should be agreed on by all parties involved in the application of the special technique. It is highly recommended that appropriate testing by independent laboratories be performed.

8.2 General requirements

The technique of external strengthening by means of FRP EBR can be applied under the following general conditions:

1. On structural elements in a dry or humid environment. Specific requirements are given for these two environmental classes to ensure good bonding. Moreover, in humid environment it should be verified that the internal humidity of the structure (dampness) is not negatively affected by the bonded reinforcement and vice versa. Application of the technique under other environmental conditions (such as under water or on a substrate continuously saturated with water), should be related to a

special study of the bond behaviour. Even if the adhesive ensures good bond conditions in humid environment, the dampness of the structure can still have other negative influences, such as risk of internal steel corrosion (involving spalling of the concrete cover), susceptibility to freeze/thaw damage of the concrete, etc.

2. The temperature of the strengthened parts of the structure under normal service conditions should not exceed a fraction of the glass transition temperature T_g of the adhesive or resin. This should be verified as specified in Section 8.4.1.1 (3). According to prEN 1504-4 (CEN 2001 a), the following condition applies: $T_g \geq 45^\circ\text{C}$ or the maximum shade air temperature in service + 20°C , whichever is the higher.
3. Careful consideration should be given to aspects such as: high differential temperatures between the FRP EBR and the substrate under service conditions, fire protection, protection against UV, possible occurrence of damage, vandalism, etc. (see also Chapter 9).
4. The application of the FRP EBR for strengthening of structures does normally not confine or arrest defects or potential damage mechanisms. Also the concrete should be sound. These aspects should be verified and preceding repair should be executed if needed, as discussed in Section 8.3.1.
5. The strengthening technique should be performed according to the specifications and requirements given in the following sections. In addition, the instructions given by the manufacturer of adhesives, resins and FRP materials should be taken into account. In conjunction herewith, all necessary design drawings should be available. Furthermore, quality control should be performed in accordance with Section 8.4. All information used for the design (including basic assumptions) should be confirmed based on the quality control tests. The application of the FRP EBR should be performed by qualified and trained workers (preferably, the FRP EBR system and the operators should be certified by an independent certification body).

8.3 Practical execution

The application of the FRP EBR should be performed in accordance with the following procedure. In addition, any special specifications given by the manufacturers of adhesives and FRP reinforcement should be followed provided that they are not at variance with these specifications unless backed up by adequate research data. The described practical execution is valid for the basic technique (see Section 8.1.1). Also reference is made to Section 8.4. “Quality control”. The procedure for the practical application of the externally bonded FRP reinforcement is depending on the type of FRP EBR, “prefab” or “wet lay-up” (Table 8-1). An overview of the basic steps in applying the FRP EBR is given in Fig. 8-1.

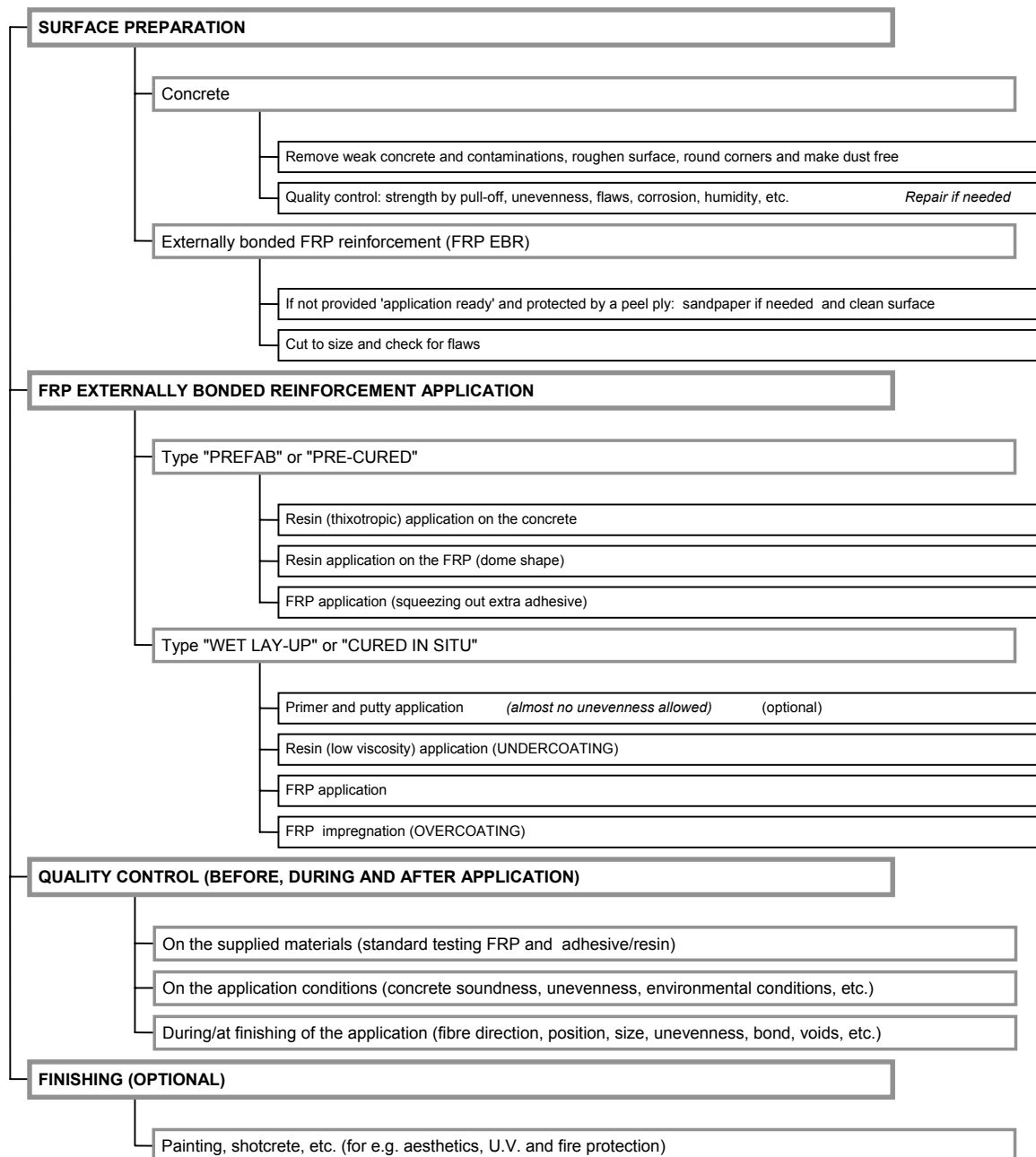

Fig. 8-1: General scheme for practical execution and quality control.

8.3.1 Preceding repair

The FRP EBR generally does not stop existing problems such as steel corrosion, water leakage, high chloride values, etc. Potential damage mechanisms such as the risk of steel corrosion in the existing member should be sufficiently low and the concrete should be sound. These aspects should be verified. If needed the strengthening has to be preceded by concrete repair and internal steel protection techniques (FIP 1991). The following aspects should be considered:

- The soundness of the concrete substrate should be verified as specified in Section 8.4.3.4. The minimum concrete tensile strength should be greater than $\boxed{1.5}$ N/mm². If

the deteriorated or damaged concrete has reached a depth that no longer allows shallow surface repair, replacement of the concrete should be considered.

- Although the external reinforcement may act as a (partial) replacement of the steel reinforcement, corrosion should be stopped to avoid damage to the concrete due to expansive rust. This damage may result in a decreased bond strength and an increased susceptibility to freeze-thaw action. Repair or protection is needed if the steel is already corroded or is likely to start corroding. With respect to the latter the carbonation depth and chloride content may need to be verified. Generally, chloride concentrations larger than $\overline{0.3}$ % by weight of cement are assumed as dangerous.
- To reduce the risk of reinforcing steel corrosion, to solve leakage problems, to avoid weak bond strength at horizontal cracks, etc., wide cracks may need sealing by means of injection. Any cracks (or construction joints) wider than $\overline{0.2}$ mm or liable to leakage should be injected by suitable compatible low viscosity resin to fill and seal the cracks. Also, repair of porous concrete and joints to restore water retaining may be of relevance.

8.3.2 Preparation of surfaces

8.3.2.1 Concrete substrate

It is important that the preparation of the concrete substrate is carried out well to provide an adequate bond with the adhesive.

1. The substrate should be roughened and made laitance and contamination free, in such a way that the concrete quality can be utilized in an optimum way. This is done preferably by means of high pressure blasting (sand, grit, water jet blasting) or grinding. In the case of blasting the concrete surface should resemble coarse sandpaper with minor exposure of aggregates. Most of the wet lay-up systems require a smoother surface (see Table 8.2) so that in this case grinding may be most appropriate or so that the application of a putty is needed after roughening by means of blasting. When using water jet blasting, further application of the FRP EBR should only be executed when the concrete is sufficient dry again (see point 6 below). Mechanical methods (e.g. scabbing, etc.) that may compromise the quality of the outermost concrete should not be allowed (unless the reduced tensile strength and bond characteristics are taken into account in the design). Regardless of the method, execution should not damage the concrete.
2. The concrete should be sound and free from serious imperfections (grind nests, steel corrosion, wide cracks, etc.) and potential damage mechanisms, as outlined in Section 8.3.1.
3. The unevenness that can be allowed depends on the type of FRP EBR. Strips (or laminates) already have their final stiffness before application and are applied with a high viscosity thixotropic adhesive. In this way, they are less sensitive to unevenness. Fabrics and sheets are very flexible and will follow any unevenness. As a result, the implications of the concrete unevenness are more important for fabrics and sheets. Allowable values are given in Table 8-2. Limitations for the unevenness of the FRP EBR after application are discussed in Section 8.3.3.

Type of FRP EBR		
	Permissible unevenness on a 2.0 m base (mm)	Permissible unevenness on a 0.3 m base (mm)
“Prefab”, thickness > 1 mm	10	4
“Prefab”, thickness < 1 mm	6	2
“Cured in situ”	4	2

Table 8-2: Allowable values of unevenness of the concrete surface.

4. Because of the important limitations concerning concrete unevenness, often a putty is supplied together with the resin for wet lay-up systems. This putty shall meet all requirements concerning concrete repair products. The application should be according to the specifications of the manufacturer and the compatibility of the putty and resin for sheet application should be proved.
5. The prepared surface should be dust free before further application of the strengthening technique. This is achieved by cleaning by means of vacuum or oil free compressed air.
6. The prepared surface should normally be surface dry. The allowable surface moisture content is given by the manufacturer. It is noted that certain adhesives can be applied in humid environment. Requirements for these adhesives are given in Section 8.4.1. The concrete surface is under no conditions allowed to be wet. The temperature at the concrete surface should exceed the actual dew point (which also depends on the air humidity) with 5°C . If not, artificial heating and dehumidifiers may be required.
7. The concrete surface shall be marked where the FRP EBR has to be applied. For complicated strengthening lay-outs the pre-cut FRP shall be applied temporarily to the concrete. For the application of sheets or fabrics around sharp edges, corners shall be rounded with a radius as specified on the design drawings. If mechanical anchorages are to be provided, all necessary preparations should be performed in an adequate way.
8. Application of a primer is normally not necessary. However, if specified by the manufacturer of the adhesive a primer shall be used according to the specifications given by the manufacturer. A primer may also be specified before applying a putty, which is often used to ensure concrete surface evenness.

8.3.2.2 FRP EBR

Strips and laminates (prefab type). The strips should be supplied to site at the specified width and cut to the necessary length as specified on the design drawings. They should be free from any contamination like oil, dust, carbon dust, release agents, etc. For strips provided with an in-built peel ply, to ensure a clean surface, the ply should be removed immediately before application and the surface must not be touched by hand again. If the strips are provided without a peel ply but with a surface ready for bonding, handling should be with extra care. Other strips usually require abrading and wiping clean before use, to obtain a satisfactory surface to which to bond. This should be performed as specified by the manufacturer. The strips should be handled with clean gloves and under dry conditions. They have to be verified for possible damage resulting from transportation, handling or incorrect cutting. The strips and laminates shall be free from unintended curves, bows, wraps, undulations or twists.

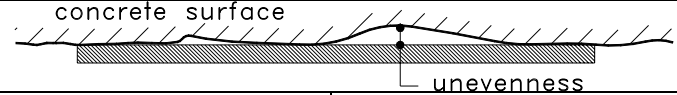
Sheets or fabrics (wet lay-up type). They are cut to the necessary plan-dimensions as specified on the design drawings. They should be kept free from any contamination and checked for possible damage resulting from transportation, handling or wrong cutting. Protecting foils or in-built peel-plies should only be removed just before application. Handling and preparation precautions provided by the manufacturer should be followed. They have to be verified for possible damage resulting from transportation, handling or incorrect cutting. The sheets and fabrics shall be free from wraps, twists or fibre misalignments.

8.3.3 FRP EBR application

The application will depend on the type of FRP EBR. For strips and laminates (prefab type) the adhesive ensures bonding only. Often a high viscosity thixotropic adhesive is applied. For sheets and fabrics (wet lay-up type) the resin ensures both bonding and impregnation, which calls for a low viscosity material. The viscosity should still be sufficient to apply the sheets at the soffits of members.

The application of the FRP EBR is performed according to the specifications given in this section and applying appropriate quality control measures as specified in Section 8.4. In addition, the information provided by the manufacturer in terms of allowable temperatures and relative humidity, mixing ratio, mixing time, pot life, open time, shelf life, provisions given by the safety data sheet, provisions concerning the environmental impact, curing duration, etc. should be taken into account.

The ambient temperature and relative humidity should be within the limits specified by the adhesive or resin manufacturer. The application should be completed within $\boxed{80}$ % of the pot life (adhesive application) and open time (time for making the joint) of the adhesive at the prevailing temperature.

After application and curing, the FRP should be essentially straight (concave surface may result in FRP peeling). Expressed as the depth of the surface variation with respect to a straight base length of $\boxed{0.3}$ m, the unevenness should be limited to $\boxed{4}$ mm for “prefab” systems and $\boxed{2}$ mm for “wet lay-up” systems.

8.3.3.1 “Prefab” type (strips or laminates)

The adhesive is applied as a thin layer to the concrete immediately after mixing. The adhesive is applied to the FRP sheet in a dome shape (100 mm plate width: maximum height about 5 mm), having slightly more thickness along the centre line of the plate. This reduces the risk of forming voids when the strip is applied. The strip is offered to the concrete surface, applying pressure by means of a rubber roller to ensure intimate contact with the concrete. The extra adhesive should be squeezed out along the sides. Also, the pressure is applied in such a way that no voids are formed (going from the centre to the outer). The final bond line should be of equal thickness along the strip and should correspond to a minimum adhesive thickness of 1.5 to 2.0 mm. Normally, the strips are applied in one layer. Unless approved by testing, a maximum number of layers and total thickness as specified in Chapter 7 is allowed.

Alternatively, instead of applying the adhesive to both the concrete and the strip, adequate results have been reported when applying the adhesive only to one surface. If backed up by adequate research data, this or other alternatives are allowed.

At crossings, the change in thickness of the adhesive should be gradually applied so that the requirements of Table 8-2 are met.

If masking tape is put on the concrete either side of the strip before gluing, the adhesive surplus can be removed more easily.

Normally, no external pressing devices need to be applied during curing.

8.3.3.2 “Wet lay-up” type (sheets or fabrics)

To achieve the required evenness of the concrete surface it will often be specified to apply (a primer and) a putty. This shall be done in accordance with the specifications given by the manufacturer. Next, a low viscosity resin is applied to the concrete (or putty) with sufficient thickness (however the adhesive should remain as an even thickness), by means of a roller brush or a toothed trowel. This process is known as ‘undercoating’. Then, the fabric or sheet is applied by pressing it manually onto the adhesive in such a way that it is stretched without introduction of voids. Impregnation and further pressing of the sheet is performed by applying adhesive on top of the fabric or sheet (after removal of the paper backing, if present) with a roller brush. This is called ‘overcoating’. The final bond line should be of an even thickness along the sheet.

Alternative to the above procedure and to increase the level of quality insurance, the fabric or sheet can be impregnated with the resin in a saturator machine. This enables to saturate the FRP EBR at a better-controlled resin rate and with a more uniform thickness. The wetted fabric or sheet is applied to the sealed substrate.

Often multiple layers will be applied. Unless otherwise specified, this may be done before the previous layer has cured. Unless approved by testing, the maximum number of layers and total thickness shall be as specified in Chapter 7.

Normally, no pressing devices need to be applied during curing.

8.3.4 Finishing

Some form of finishing may be required for aesthetic purposes. In terms of fire protection, possible occurrence of damage, protection against ultra violet radiation, a finishing layer can be crucial to the long-term integrity of the strengthened structure. Different types of finishing layers can be provided such as painting, shot-concrete or fire protection panels. These finishing layers should be applied according to the specifications given by the manufacturer. The compatibility between the externally bonded reinforcement and the finishing layer should be proved. If finishing layers or toppings involve heating, this should not damage the bond integrity.

8.4 Quality control

The quality control specifications given in this section only concern the FRP EBR and its application. For specifications concerning concrete repair techniques and steel corrosion protection techniques, reference is made to corresponding guidelines.

8.4.1 Characterization and quality control of the strengthening materials

8.4.1.1 General

The adhesives and FRP EBR used shall be characterized according to standard test methods. The properties should be provided by the manufacturer, who should be able to prove that the tests were performed by an independent laboratory and according to the specified test methods. Furthermore, the manufacturer should guarantee that there is sufficient quality control during production. In addition, quality control testing should be undertaken during the practical execution, as specified in Section 8.4.3. The products are to be delivered in accordance with Section 8.4.3.1.

If possible, the characterization of materials (according to standard test methods and performed by independent laboratories) should be supervised by a certification body. In this way the products can be certified.

Although standard test methods specifically developed for the characterization of FRP EBR systems are scarce, in the following reference is made to a number of tests that can be used. More specific or alternative test methods and procedures may become available in the future. In addition to the test methods, some requirements are mentioned.

8.4.1.2 Bonding agent

(1) General

A two-part cold cured adhesive, comprising resin and hardener, is used for FRP bonding. The adhesive is normally epoxy based and similar to the epoxies used for steel plate bonding. Long term experience with epoxy adhesives, including durability, over a period of about thirty years in civil engineering prove their suitability. Other adhesives may be used as long as they provide equivalent performance and that their long-term durability is acceptable. Adhesive requirements for structural bonding are also specified in prEN 1504-4 (CEN 2001 a).

(2) Physical properties

Viscosity and thixotropy. The polymer bonding agent shall be capable of being applied readily, after mixing according to the manufacturer's instructions, in layers corresponding with the specified adhesive application and with the specified minimum thickness of the final bond line (Section 8.3.2.), providing thorough wetting of the adherents. The viscosity of the adhesive should be optimised with respect to the intended use and will differ considerably for “prefab” and “wet lay-up” types of FRP EBR. Thixotropy may be required if a high viscosity is wanted with yet sufficient wetting ability during spreading. Different grades of an adhesive, each applicable within a certain working temperature range, may be made available. The viscosity shall be determined according to ISO 3219 (ISO 1993 a) (also EN ISO 3219, CEN 1995). The suitability for application to vertical surfaces, soffits and horizontal surfaces is verified according to EN 1799 (CEN 1998 a).

Curing conditions and shrinkage. The adhesive shall be capable of curing to the required strength under the most extreme conditions with respect to temperature and humidity. These conditions are specified by the manufacturer. A maximum temperature may be specified in relation with the pot (or workable) life and the viscosity. The minimum temperature at which

curing is still possible generally equals 5 °C. The maximum relative humidity, above which insufficient adhesion is obtained, often equals 80 %. On curing, the adhesive shall undergo negligible shrinkage, meaning less than 0.1 % determined according to prEN 12617-3 (CEN 2001 b).

Pot life, open time and shelf life. The mixed adhesive, before application to the prepared surfaces, shall have a pot life in excess of 40 minutes at 20 °C (or at the typical application temperature). The pot (or workable) life is determined according to prEN 14022 (CEN 2001 c). The time after application of the adhesive (open time), within which the joint can be made, shall exceed 20 minutes at 20 °C. The open time is determined according to EN 12189 (CEN 1999 a). The shelf life of all adhesive components shall exceed 6 months in original containers, stored at $5 - 25$ °C. Adhesives shall not be used if their shelf life, pot life or open time has been exceeded.

Glass transition temperature. The heat distortion temperature (often characterized by the glass transition temperature T_g) should be sufficiently large with respect to the service temperature: $T_g \geq 45$ °C or the maximum shade air temperature in service + 20 °C, whichever is the higher. The glass transition temperature is determined according to prEN 12614 (CEN 2001 d).

Moisture resistance. Moisture transport through the adhesive should be minimised. The maximum water absorption after immersion in water, according to prEN 13580 (CEN 2001 e), shall not exceed 3 % by weight.

Filler properties. Fillers used with the adhesive shall be an electrically non-conductive material, be highly moisture resistant, be able to withstand temperatures up to 120 °C without degradation and have a maximum particle size of 0.5 mm.

(3) Mechanical short-term properties of the cured adhesive

Modulus of elasticity in bending (flexural modulus). The modulus of elasticity shall be determined according to ISO 178 (ISO 1993 b) and should be within the $2000 - 15000$ N/mm² range. The lower limit relates to a restriction of creep, the upper to minimize stress concentrations.

Shear strength. A minimum value of 12 N/mm² at 20 °C is required. The shear strength is determined according to EN 12188 (CEN 1999 b).

Adhesion strength. The adhesion strength of the bonding agent, determined according to EN 12188 (CEN 1999 b) should be larger than 15 N/mm² at 20 °C.

Compressive strength. The compressive strength shall be determined according to EN 12190 (CEN 1998 b).

(4) Durability and long-term properties of the cured adhesive

The durability shall be proved based on laboratory accelerated durability testing or based on long term experience (over a period of at least 15 years) in conditions similar to the proposed use. On durability, fatigue and creep under sustained load testing, reference is made to prEN 13584-1 (CEN 2001 f), prEN 13733 (CEN 2001 g), prEN 13894-1 (CEN 2001 h) and prEN 13894-2 (CEN 2001 i). These test methods may need to be varied with respect to FRP EBR.

8.4.1.3 FRP EBR

(1) General

FRP EBR is basically defined by the type(s) of fibre, the resin binder, the fibre directions and fibre volume fraction. Mostly, FRP EBR based on carbon fibre and epoxy resin are used. However, also FRP based on e.g. aramid or glass fibres can be used. Besides epoxy, also other types of resins can be used. The direction of the fibres can be unidirectional or multi-directional. In all cases, the fibres should be continuous.

(2) Type of FRP EBR and geometrical characteristics

The type of FRP EBR and dimensional characteristics should be specified, in terms of: “prefab” type (plates or strips) and “cured in-situ” (sheets or fabrics), type(s) of fibre, resin type, fibre directions, width, length and nominal thickness.

The definition of nominal thickness of the FRP should be clearly indicated. Generally, reference is made to the global thickness or the dry-fibre thickness. A discussion on this aspect is provided in Chapter 2, Section 2.1.5. If comparison of mechanical properties is made between strips (or laminates) and sheets (or fabrics), the possible differences in defining the nominal thickness should be borne in mind! The equivalent dry-fibre thickness of sheets with multiple fibre directions is related to the fibre direction.

(3) Physical properties of the FRP EBR

Fibre fraction. The fibre weight fraction, the fibre volume fraction or the fibre weight by unit area for each fibre direction shall be provided.

Amount of resin for impregnation. The minimum amount of resin, per unit area, to impregnate “cured in-situ” sheets or fabrics should be known.

Coefficient of thermal expansion. The coefficient of thermal expansion shall be determined according to EN 1770 (CEN 1998 c).

Glass transition temperature. The glass transition temperature of “prefab” FRP types is typically higher (due to factory processing) than that of the bonding agent. The glass transition temperature of “wet lay-up” systems is determined by the resin used for bonding and impregnation.

Moisture absorption and chemical stability. As also specified for the bonding agent the moisture absorption of the cured FRP should be limited. Although FRP EBR systems generally have good chemical stability, the durability of the system in the environment of subject should be demonstrated [see point (5)].

(4) Mechanical short-term properties of the FRP

Tensile strength, elastic modulus and tensile failure strain. The basic properties of the FRP sheet shall be determined by tensile testing. The tensile strain, the modulus of elasticity at the origin (tangent modulus), the secant modulus (defined between 20 - 60 % of the ultimate load) and the failure strain shall be determined. No standard test method is available, although reference can be made to test methods for FRP materials used in other fields: EN

ISO 527-5 (ISO 1997), EN 2561 (CEN 1996), ASTM D3039/D3039M (ASTM 1995). The test results should be given as mean values and standard deviation. For the tensile strength and the E-modulus it should be clearly stated which value for the nominal thickness has been taken in consideration. The properties obtained from tensile testing are related to the fibre direction. For FRP sheets with multiple fibre directions the properties should be determined for each fibre direction.

(5) Durability and long-term properties

The FRP should have sufficient resistance against moisture, chemicals and UV radiation or should be protected from it by protecting layers. The creep characteristics of the FRP may be required for the design. A discussion on these aspects is provided in Chapter 9 “Special design considerations and environmental effects”.

8.4.1.4 Composite action between FRP EBR, bonding agent and concrete

(1) General

The success of strengthening by means of FRP EBR will be highly dependant on the quality of the bond between the three acting materials: FRP EBR, bonding agent and concrete substrate. Good bond behaviour should be guaranteed under specified (extreme) application conditions and with regard to the long-term durability.

(2) Bond between FRP EBR, bonding agent and concrete

Different types of bond testing can be carried out. Prior to these tests, it is recommended that an applicability test will be performed from which further test specimens for bond testing can be taken. With the applicability test the application of the adhesive under specified conditions is verified. At the same time this test can be used for training.

Applicability test. The FRP EBR is applied to a concrete slab, according to the procedure specified in Section 8.3. The material should have a length of 1 m, a width corresponding to normal application conditions and a thickness corresponding to the maximum allowable number of layers. The application is performed on the soffit of the slab, the slab being positioned horizontally at an elevation of about 2 m. The execution is performed in a climate-controlled room under specified conditions (minimum temperature and maximum relative humidity). All materials shall be put $\boxed{24}$ hours in advance under the specified conditions. The concrete slab shall be sufficiently large, depending on the FRP EBR dimensions, and shall have a minimum thickness of $\boxed{40}$ mm. The concrete quality should be such that a minimum concrete tensile strength of $\boxed{3}$ N/mm² is guaranteed. Depending on the envisaged application, the concrete substrate will be either ordinary concrete or repaired concrete. In the latter case, an additional repair mortar layer with thickness $\boxed{10}$ mm is applied on the concrete surface. The strengthened slab is cured under the specified conditions for $\boxed{7}$ days and additionally during an extra $\boxed{7}$ days under laboratory conditions ($\boxed{20 \pm 5}$ °C). After execution the FRP EBR is evaluated in terms of unevenness, thickness of the bond line and voids (see Section 8.4.3). In addition concrete cores \varnothing 50 mm are drilled for direct tensile testing after 3, 7 days and 14 days to evaluate the bond performance (see next point). The above testing conditions refer to

"dry environment". If the adhesive allows for "humid environment" the concrete slab will be immersed in water for 7 days. The application test starts 2 hours after taking the slab out of the water and drying the surface with a towel until surface dry.

Bond performance in direct tension. The bond performance can be evaluated by means of direct tensile testing of the FRP EBR/bonding agent/concrete substrate combination. Test specimens are obtained by taking cores from the applicability test specimen. Tests are performed at 7 days and at 14 days under the specified curing conditions. In addition, for outdoor exposure, durability testing (see below) shall be performed. The test method will be according to EN 1542 (CEN 1999 c). The failure should be located inside the concrete.

Durability testing. The durability will be evaluated based on the bond performance in direct tension, after freeze/thaw or outdoor ageing. The cores taken from the applicability test specimen and cured under the specified conditions are respectively submitted to 10 freeze/thaw cycles or to outdoor climate, before testing them in direct tension. The freeze/thaw tests are according to a cycle of 4 hours at -20 °C, 4 hours at +60 °C and 16 hours under water at 20 °C. The specimens stored in an outdoor climate are left exposed for minimum 1 year according to prEN 13733 (CEN 2001 g).

Bond performance in shear. No standard test method is currently available, although this subject is under investigation in a round robin test (TMR ConFibreCrete, fib TG9.3 and ISIS 2001).

(3) Quality of adhesive bonded joints

If the FRP EBR is not available in quasi-continuous lengths or if more layers are applied than the maximum specified by the supplier (Chapter 7), adhesive bonded joint testing has to be performed (so-called lap shear strength test). This can be done according to EN 1465 (CEN 1995).

8.4.2 Qualification of workers

The strengthening technique (including possible preceding repair techniques) shall be performed by qualified and experienced workers. The team chief or work co-ordinator (foreman) shall be trained and qualified on all aspects of the applied techniques and shall be present during work at all times. Training can be performed according to Section 8.4.1.3 (2).

8.4.3 Quality control on the practical execution

8.4.3.1 General remarks

The products shall be provided with the following information:

- General data (such as: name, type and function of the product, product components, name and address of the manufacturer, batch number and expiry date).
- On request, data concerning the material properties according to standard test methods (Section 8.4.1).
- Information concerning handling, transportation and storage (such as: pot or workable life, shelf life, mixing ratios, mixing requirements, storage conditions, application conditions, application guidance, cleaning agents, curing time in between primer and putty application, etc.).

- Safety data (such as: toxicity, inflammability, environmental impact, etc.).

The components of the bonding agents (primer, putty, adhesive) shall be provided separately and pre-dosed according to the mixing ratio. Preferably, one component (in normal-sized packing) is added to a second component (in over-sized packing). It should be verified that no material remains in the packing of the first component. The mixing speed should be sufficiently low to avoid formation of air bubbles. Mixing should be continued until a homogeneous colour is obtained. It should be verified that no badly mixed zones are remaining.

Special care should be taken in avoiding any type of damage to the FRP EBR during transportation, storage and handling. Cutting of FRP EBR to length according to the design drawings is allowed on construction site, if cutting is performed according to the specifications of the manufacturer and if no further damage to the sheet is initiated.

8.4.3.2 Quality control of the supplied materials

Representative test samples should be taken from the supplied materials. The number of control tests will depend on the importance of the job (the total area to be strengthened by FRP EBR bonding, the difficulty in strengthening lay-out and whether or not the materials are supplied in total). At least $\boxed{3}$ tensile tests of the FRP EBR and $\boxed{6}$ bonding agent compression tests (according to Section 8.4.1.1 and/or 8.4.1.2) should be performed, unless the products are certified by independent certification bodies.

8.4.3.3 Quality control on the application conditions

The suitability of the concrete substrate for bonding should be verified before and after repair techniques. The concrete quality is verified based on the tensile strength of the concrete surface, by means of pull-off testing according to EN 1542 (CEN 1999 c). The obtained strength should be equal to the tensile strength of the bulk concrete (locus of the failure to be totally within the concrete), unless taken into consideration in the design. The minimum strength should be $\boxed{1.5}$ N/mm². Secondly, the unevenness of the (repaired) concrete surface is checked and should be within the limits given in Table 8-2. Furthermore, air humidity, air temperature and surface moisture and temperature of the concrete substrate are measured to evaluate the environmental conditions ("dry" or "humid" conditions, dew point, temperature limitations for use of the adhesive, maximum allowable relative humidity, etc.).

8.4.3.4 Quality control on the application process

During the execution and at finishing quality control verifications are performed to ensure good quality of the strengthening:

- Quality control to verify that the proper execution procedure is followed and that the FRP EBR is applied in the given direction and with proper amounts of fibres and polymer. It has also to be ensured that proper mixing and manipulation of resin and correct surface preparation takes place.
- Verification of satisfactory unevenness of the FRP EBR and bond line thickness after execution.
- Quality control of the bond interface as outlined in the Section 8.4.4.

8.4.4 Bond quality control after the practical execution

Further quality tests of the bond interface (presence of voids or defects, bond strength) may not be necessary when the contribution of the bond interface in stress transmission between the FRP and the concrete is negligible (i.e. columns wrapping). In most cases however, it may be required to perform quality control of the bond interface.

Quality control of bonding can be achieved through Non-Destructive Testing (NDT) and Partially-Destructive Testing (PDT). NDT are to be preferred for testing critical areas of the strengthening where FRP contribution is assumed to be fundamental, and in general in all that situations where the strengthened surface is small in comparison with the area damaged by PDT. To aid the quality control, during execution separate test areas may be foreseen. These areas are to be executed together with the actual FRP EBR application and under exactly the same conditions.

Different tests can be performed as outlined in the following. It is recommended that at least 3 bond tests are performed at 3 days and/or at 7 days and that critical bond zones are scanned for the presence of voids.

8.4.4.1 Partially destructive techniques

Surface adherence pull-off test (see also Section 8.4.1.4). Partial coring is performed in the FRP EBR, 5 mm into the concrete. A disc is glued and after hardening pulled off in direct tension. The test is performed according to EN 1542 (CEN 1999 c).

Surface adherence shear test. If a FRP test strip has been glued on the concrete surface close to an edge and extending from it, the extending part of the strip can be gripped and submitted to tension until rupture at the strip-concrete interface occurs. In this type of test the bond interface is submitted to pure shear.

Surface adherence torque test. A ring disc is glued on the FRP strengthening surface and partial coring is performed at the outer and inner diameter, extending 5 mm into the concrete. After hardening the disc is twisted off. In this type of test the bond interface is submitted to torque.

8.4.4.2 Non destructive techniques

To verify that no large voids in the adhesive are present the following tests may apply.

Tapping. Normally voids can be detected by means of “tapping” the bonded surface with a steel stick with diameter 5 mm and with a rounded tip.

Ultrasonic pulsed echo techniques. A high frequency ultrasonic beam is used to scan FRP-concrete interface and bonding defects are located through echoes generated by acoustic impedance mismatching. Echo amplitude techniques are to be preferred to time-of-flight ones. Effectiveness of the ultrasonic echo technique is limited to “gaseous” defects such as air bubbles or gas film detachments, is critical under FRP loading conditions and requires smooth FRP surfaces and well-experienced personnel. FRP areas next to edges or with small bending radius cannot be successfully tested with this technique. Since technique is time consuming, it is strongly recommended only for the strengthening areas where bonding is critical.

Ultrasonic transparency techniques. A low frequency ultrasonic beam is used to scan paths orthogonal to the strengthened surface where one of the transducer is placed, while

another transducer is located on the opposite face of the concrete element. Time-of-flight and wave attenuation are recorded. The technique is applicable only when both the strengthened and the opposite surface are easily accessible and is time consuming. Its use should be recommended only in particular situations.

Thermography. Thermographic NDT in direct dynamic condition has been successfully applied to bonding evaluation. Testing should take place with the specimen at thermal equilibrium, applying a homogeneous heating (or cooling) to the FRP free surface and recording its surface temperature during the thermal transient with an infrared imaging system. Defects are located as hot (or cool) spots due to different thermal properties of degraded bonding. Severe limitations of the technique arise with thick overlays and with FRP materials with a high thermal conductivity, such as CFRP. Although thermography is strongly recommended, great care has to be used in calculating the smallest detectable defect in order to ensure it is not critical for crack propagation. Calculation can be performed using thermodynamic model of the strengthening.

Other dynamic techniques. At present some other dynamic techniques based on impact spectrum analysis and on surface acoustic wave propagation are under evaluation.

8.4.4.3 Corrective actions for bonding defects

If considerable voids are present, the FRP should be stripped off and new FRP reinforcements should be glued. Alternatively, they may be injected with a compatible resin, according to a procedure agreed on by all parties. Herewith, the reduction in FRP sheet section, the localized injection pressure, and all other negative influences resulting from the injection should be taken into consideration to see if still all design requirements are met.

8.4.5 In-service inspection and maintenance

A manual of procedures for inspection and maintenance for the repaired and strengthened structure should be prepared for the maintaining authority.

9 Special design considerations & environmental effects

9.1 General

If applied properly, FRP strengthening systems appear to offer the same or improved life cycle cost estimates compared to other strengthening systems. Although the durability of FRP and concrete is well documented, the combined system is raising warranted concerns concerning the overall long-term behaviour.

The FRP-concrete interface is the critical component to the effectiveness of most FRP structural strengthening applications as this is the location where the transfer of stresses occurs. Field experience has shown that the bond between FRP and concrete cannot always be assured. Bond quality is influenced by the condition of the existing concrete, surface preparation of the concrete substrate, quality of the FRP application, quality of the FRP itself and durability of the resin. In the following attention is paid to the durability first of all of the FRP itself and then to that of the whole strengthened system.

9.2 Glass transition temperature

The glass transition temperature (T_g) is the temperature above which FRP performance can be expected to drop dramatically. The thermal energy supplied above T_g allows the resin chains to move and become more flexible. This will result in a reduced bond capacity. Also, it lowers the load or sharing capacity of the resin and results in preferential loading of individual fibres (the shorter ones). Since the load is no longer shared among the group of fibres, the loading on individual fibres may exceed the capacity of the fibre and it breaks. The next shorter fibres pick up the load and if the stress level is too high, they break and so on. Ultimate load carrying capacity of the FRP can be lowered by 30-40% in extreme cases (Kelley et al. 1999).

To avoid a premature debonding because of an excessive temperature increase, maximum service temperature must be lower than the glass transition temperature of the resin and the adhesive. However, one has to consider that T_g may vary in time due to several environmental parameters (temperature, moisture, etc.). High temperature could act like a post-cure on the material and therefore increase T_g . Absorption of moisture by the resin will lower T_g (see Section 9.4). A requirement with respect to this issue is given in Chapter 8, Section 8.4.1.2. Furthermore, classical action combinations including temperature effects must be taken into account according to Eurocode 2. If the strengthened member is to be subjected to high temperature, an adhesive with a correspondingly high T_g must of course be selected. There are two possibilities: a cold-cure resin with an initially high T_g can be used, or post-cure can be performed on the resin to achieve a higher T_g .

9.3 Fire design and protection

9.3.1 General

If no special measures (like protective linings) are taken, the externally bonded reinforcement may be lost during fire due to the weakening of the adhesive. In such cases verification for the unstrengthened element in the accidental design situation (Chapter 3) must be performed.

The evaluation of the fire resistance of concrete elements allows different types of analysis. A global structural analysis can be performed, in which case indirect thermal actions (thermal elongations, restraints etc.) must be considered throughout the whole structure. Where the analysis is done by evaluation of individual concrete members (used for classification of elements F30, F60, etc.), indirect thermal actions should not be considered.

9.3.2 Strengthened elements without fire protection

In this case the strengthening of the concrete element will be lost very quickly in a fire, due to the high temperature that weakens the adhesive layer between the strengthening element and the concrete. The fire resistance of the strengthened element can be evaluated by analysing the (accidental) unstrengthened concrete section. The rules that are applicable to reinforced and prestressed concrete elements, described in EC2, Part 2-2: Structural Fire Design, may also be applied here. Hence, fire resistance may be evaluated using tabulated data (minimum dimensions and minimum concrete cover for different types of elements), using a simplified calculation method (thermal analysis and mechanical analysis with reduced material properties) or using a general calculation method (thermal and mechanical analysis with temperature dependent material properties). If using tabulated data, one has to keep in mind that the values in these tables are calculated according to the accidental load level of the unstrengthened element. The strengthened element in case of fire must be evaluated with a load level according to the accidental load level of the strengthened element. Therefore, the tabulated values must be changed according to the higher accidental load level of the strengthened element.

9.3.3 Strengthened elements with fire protection

When fire protection is provided for the strengthened element, the fire resistance must be evaluated using a more refined calculation method (like the general calculation method proposed above). The analysis will consist of a thermal analysis to determine temperature distributions in the element, followed by a mechanical analysis with temperature-dependent material properties. The dimensioning of the protection will be based on a limitation for the temperature rise in the adhesive layer (weakest element of the cross-section) during a certain time. This temperature limit depends on the type of adhesive used but will usually be in the range of 50°C to 100°C.

9.4 Moisture

9.4.1 Effect of water absorption on FRP

Presence of moisture is a particularly harsh environmental parameter for all structural materials. Steel rusts, concrete can carbonate, wood rots, resin chains can split and glass loses tensile strength. With FRP materials, the first concern is how well the resin matrix resists the effects of prolonged exposure to water, either fresh or salt. Experience from the boat and the military industry has shown that the effects take place over an extremely long period of time (Lubin and Donohue 1980).

The resin matrix will absorb water. The amount of water is dependent on the resin type and the water temperature. The two immediate effects of water absorption on the matrix are a reduction of the glass transition temperature and a stiffening of the resin. Both of these

effects are partially reversible in epoxy resin when the water is removed by drying. With polyesters and vinyl esters the changes can be reversible or not, depending on the time and temperature of the exposure. Epoxies have no ester linkages in their structure and thus the polymer chain is not easily hydrolysed. A maximum water uptake value of 3% by weight is normally specified for structural adhesives (Blaschko et al. 1998).

Damage to fiberglass/epoxy composites may be caused by the intrusion of moisture into the resin-fibre interface. Such intrusions may break the silane coupling agent bonds between the glass and the coupling agent and/or the bonds between the resin and the coupling agent. Further, the presence of moisture can leach sodium and other metallic ions from the glass causing loss of strength over time. Moisture is thought to gain access into the composite due to the following:

- Capillary action along the longitudinal axis of the fibre or at the resin-fibre interface.
- Transfer through cracks and voids in the structure.
- Diffusion through the matrix.

Aramid fibres absorb up to 13% by weight of moisture that can have a deleterious effect on tensile strength and can affect the resin-fibre interface. Carbon fibre is relatively inert to water and so the only effects on CFRP are those of moisture on the resin matrix.

9.4.2 Durability of an FRP-concrete system

It is crucial to consider the condition of the existing concrete (including the condition of the internal steel) prior to strengthening in order to ensure the bond quality and the longevity of the system. Basic existing problems need to be addressed before FRP systems are implemented, otherwise water and chemicals can still penetrate the concrete to further deteriorate the system by debonding or peeling action where localized stresses occur. These stresses can be due to environmental problems that include temporary water pooling in the FRP-concrete interface. Figure 9-1 (Karbhari and Howie 1997) shows the system level interactions.

The internal pore pressure is also another major concern related to the FRP moisture barrier properties. As the FRP strengthening system has a secondary effect of sealing the concrete, this internal pressure will locally accumulate. To allow moisture transfer in FRP strengthened members, sufficient gaps (zones with no externally bonded FRP) may be necessary. These gaps can also provide access to excess moisture or deleterious materials.

In the case of indoor applications and mild climates with properly restored concrete, the effects of vapor-barrier encapsulation of concrete by FRP are minimal. Fully encapsulating a concrete member with FRP can even increase its longevity by protecting it from harsh conditions (marine, chemicals environment, etc.). However, in case of poor concrete conditions, the encapsulation is at risk if the member is exposed to extreme climate cycling and/or excessive moisture. Applications of FRP to a structural element that is at risk of water pooling should not involve fully encapsulating the concrete. Good internal and surface concrete conditions, proper surface preparation, adequate concrete substrate exposure and proper application of an adequate FRP system may substantially reduce this risk (Kelley et al. 1999).

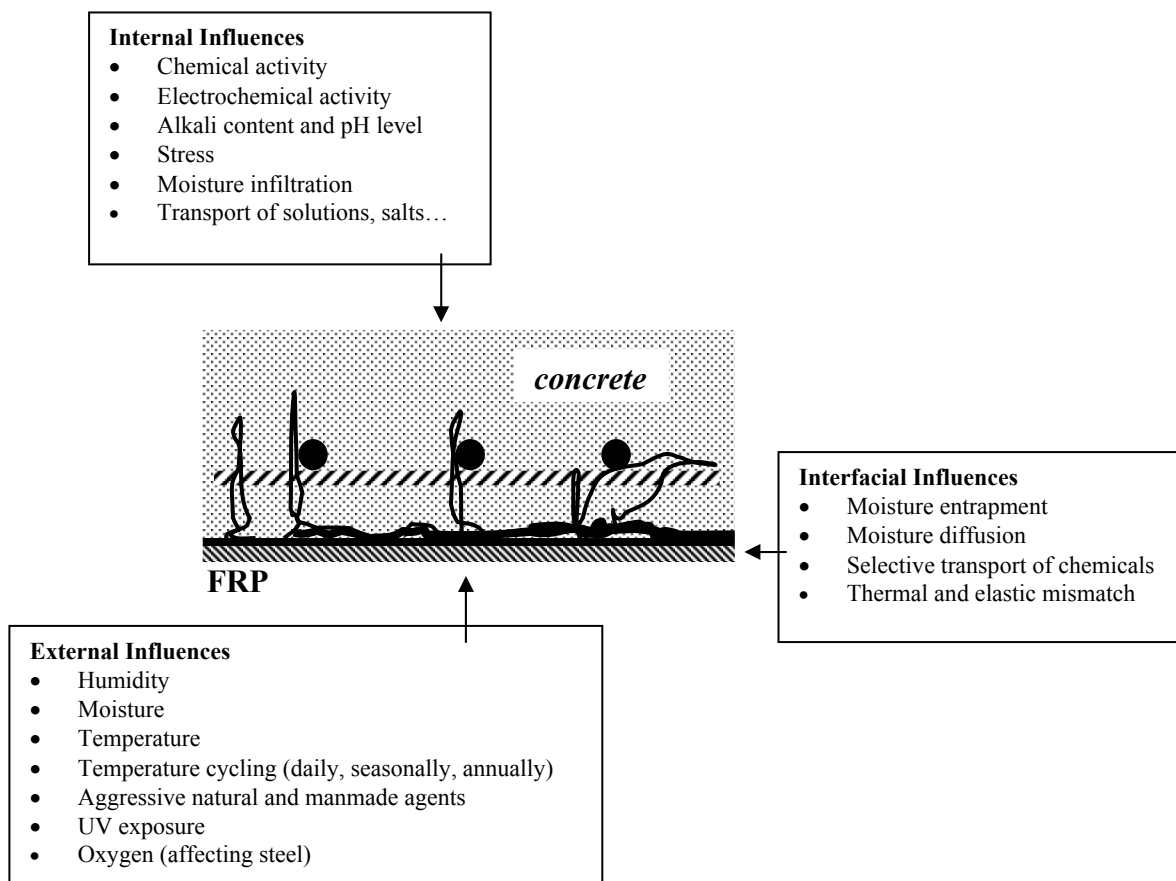

Fig. 9-1: FRP system level interactions.

9.5 Temperature Effects

9.5.1 Freeze-Thaw

As strengthening is applied to existing structures, these structures may be cracked before applying the FRP. The bonding of the FRP on the concrete may not be perfect, and some voids (or even larger delaminations) may be present in the interface layer between concrete and FRP. The expansion of freezing water in these cracks or voids may cause delamination of the FRP at the concrete-FRP interface. Hence the effect of freeze/thaw cycles on the behaviour of strengthened structures must be considered.

Kaiser (1989) studied the behaviour of strengthened beams subjected to 100 freeze-thaw (with water at 20°C) cycles between -25°C and 20°C. Uncracked and cracked beams were strengthened and tested. He found no negative effect of frost and thaw on the behaviour of the tested elements compared to the behaviour of reference elements. Green et al. (1998) studied the behaviour of freeze-thaw action on the bond behaviour between concrete and FRP. Tysl et al. (1998) introduced some delaminations and voids in the bond layer to study the influence of such defects on freeze and thaw action. They both found no significant influence of frost and thaw on the bond behaviour.

Yagi et al. (1997) concluded that repeated freeze-thaw cycles have shown little or no effect on the FRP when high quality, moisture resistant epoxies are used (Yagi et al. 1997); yet the same freeze-thaw tests on FRP wrapped concrete cylinders showed significant deterioration in strength and ductility (Soudki and Green 1997). Freeze-thaw cycling may give problems when the quality of concrete is poor (Toutanji and Balaguru 1998). Concrete,

which is not considered to be frost resistant, also contributes to the strength degradation of the wrapped cylinder. Therefore these tests are checking how well the FRP maintains some strength to poor quality concrete rather than testing the freeze-thaw resistance of the whole FRP-concrete system. In other test cases, water is allowed to penetrate the FRP-wrapped concrete at an unsealed surface (top of cylinder). Results show that the damage begins at the unsealed surface rather than within the wrapped area (Toutanji and Balaguru 1998).

9.5.2 Bond Behaviour at high and low temperatures

It is well known that when FRPs are used together with concrete to form a plate-bonded composite beam, the behaviour and integrity of the plate-adhesive concrete system not only depends on the individual materials, but also on the properties of the interfaces involved in the joint, namely, the plate-adhesive and concrete-adhesive interfaces.

However, in extreme conditions of temperature, typical of some regions of the world like in the Poles and equatorial regions, the behaviour and integrity of joints are more conditioned by component properties (plate, adhesive or concrete) instead of interfaces properties involved in the joint. Thus, in general, for high temperatures the behaviour is more conditioned by the properties of the glue, while, for low temperatures the behaviour is conditioned by the properties of the matrix's resin.

Pantuso et al. (2000) studied the behaviour of strengthened specimens with two types of unidirectional CFRP strips ($E=175$ GPa and $E=300$ GPa), evaluated at room temperature, and without internal steel reinforcement tested to failure at three different temperatures: -100°C , -30°C and 40°C . The test specimens reinforced with high elastic modulus strips showed a greater reduction in the ultimate bond force compared to the specimens reinforced with low elastic modulus strips.

Test specimens tested at -30°C and -100°C showed load versus deflection diagrams with partial sudden drop in the load (snap-back). On the contrary, test specimens tested at $+40^{\circ}\text{C}$ showed a uniform behaviour. Moreover, test specimens showed different type of failure with variations of temperature. The specimens tested at $+40^{\circ}\text{C}$ underwent bond failure in the thickness of the glue (cohesive failure). The specimens with high elastic modulus strips tested at -30°C manifested interlaminar plate failure; concrete shear failure appeared for those reinforced with low elastic modulus strips; the specimens tested at -100°C manifested interlaminar plate failure in both cases.

In conclusion, tests have shown that specimens tested to failure under low or high temperature show not only variations in the ultimate bond force, but also significant differences in the nature of debonding.

9.6 UV light exposure

9.6.1 General

Polymeric materials undergo degradation when exposed to UV-A (wavelengths between 315 nm and 400 nm) and to UV-B (wavelengths between 280 nm and 315 nm) radiation, which can cause dissociation of chemical bonds. Subsequent reaction with oxygen can lead to oxidation as well as chain cutting, cross-linking, hydrolysis or loss of other small molecules.

Surface changes in composites due to sunlight are some of the first and possibly most critical manifestations of environmental exposure. Sunlight and especially ultraviolet light can lead to a reduction of light transmissibility and colour changes in the composite. It can

also influence the mechanical properties of the composite. Although colour changes and discoloration are often perceived by the public to be an indication of strength reduction, in reality this is only a surface condition that is usually not indicative of changes in structural integrity or physical damage. Colour changes and reduced light transmissibility are primarily due to the influence of UV light on the resin matrix material and not on the reinforcing material. Indeed glass and carbon fibres are largely unaffected by UV light. Aramid fibres are only slightly affected by UV light due to the development of a self-protective layer on fibres under UV light exposure (Ahmad and Plecnik 1989).

In general, the mechanical properties of composites are only slightly influenced by UV light exposure. However the amount of deterioration is dependent on the type of resin and the fibre stacking and orientation.

- Type of resin

Polyester resins are generally more susceptible to UV light damage than epoxy resins although they have somewhat similar strength reduction. Strength reduction can cause composites to become more susceptible to matrix cracking or crazing (fine cracks at or under the surface). This could lead to other environmental problems such as increased moisture absorption and/or chemical attack.

- Fibre stacking and orientation

The importance of fibre orientation within the composite is linked to the resin matrix. Fibre dominated properties, such as tensile and flexural strengths of composites, tend to show very little degradation due to UV light exposure. However matrix dominated properties, such as shear strength, are significantly affected due to reduced resin strength.

9.6.2 Test methodology

Three major categories of testing exist:

- Outdoor
- Outdoor accelerated
- Laboratory accelerated

There is a great deal of variability and uncertainty associated with the currently used testing methodology:

- Outdoor tests: variability in weather at different sites, different times of year, different years
- Laboratory tests: reproducibility between nominally identical weathering devices is generally poor.

In most studies, UV effects are not isolated from hygrothermal effects. Therefore, it is difficult to attribute changes in properties solely to UV effects. For example, ASTM G 53 aims at simulating deterioration caused by water as rain or dew and the ultraviolet energy in sunlight. Specimens are alternately exposed to ultraviolet light alone and to condensation alone in a repetitive cycle (ASTM G53 1996). Test results according to this method on glass fabric/epoxy laminates (Steckel et al. 1998) have shown no degradation between control specimens and specimens subjected to 100 cycles (4 hours UV exposure at 60°C and then 4 hours condensate at 40°C). The effect of a potential degradation had been evaluated on the Young's modulus, the tensile strength, the failure strain and the shear strength. Identical testing on carbon fabric/epoxy laminates has shown little degradation.

Since natural environments vary with respect to geography, topography and different exposure periods, it may be expected that the effects of natural exposure will vary accordingly. ASTM G23 focuses on this problem by covering the basic principles and operating procedures for light-exposure apparatus with and without water spray employing a carbon-arc light source. This practice includes several procedures:

- Continuous exposure to light and intermittent exposure to water spray
- Alternate exposure to light and darkness and intermittent exposure to water spray
- Continuous exposure to light without water spray
- Alternate exposure to light and darkness without water spray

Tests according to the first method (Pereg 1996) have shown no reduction of the tensile properties of glass fabric/epoxy laminate after 2000 hours exposure.

9.6.3 Protection

Most specifications for the application of FRP strengthening systems should have some sort of requirement concerning painting for UV protection. UV protection can be afforded by the use of either an acrylic based paint or a polyurethane based paint. Paint should be applied within 72 hours and while the resin is still "tacky" to the touch. If "tack" is gone (resin too cured) then light blasting (brushing) or abrading of the surface before painting should be carried out. A light coloured paint (white or concrete grey) will reflect much of the heat.

Two finish coats are generally required. For example, the Department of Transportation of the State of California (USA) provides detailed information requiring the paint to withstand a UV intensity of $0.47 \text{ W/m}^2/\text{nm}$ measured at 310 nm for a minimum of 38 cycles. A cycle shall be 4 hours of ultraviolet exposure at 60°C and 4 hours of condensate exposure at 40°C .

9.7 Alkalinity/Acidity

The performance of the FRP strengthening over time in an alkaline or acidic environment will depend on both matrix and the reinforcing fibre. Carbon fibre is resistant to alkali and acid environment whereas glass fibre can degrade in these environments. However a properly applied resin matrix will isolate and protect the fibre and postpone the deterioration. Nevertheless RC structures located in high alkalinity and high moisture or relative humidity environments should be strengthened using carbon fibres (Kelley et al. 1999).

9.8 Creep, stress rupture and stress corrosion

The component parts of reinforced concrete elements have all been shown to exhibit varying degrees of creep deformation whilst under constant load. CFRP does not creep, the creep of GFRP is negligible, but that of AFRP cannot be neglected. Hence, the creep behaviour of CFRP - or GFRP - plated RC elements is governed primarily by the compressive creep of concrete (e.g. Plevris and Triantafillou 1994). As AFRP creeps itself, long-term deformations increase considerably in the case of AFRP-strengthened elements.

It must be mentioned here that creep is seldom a controlling factor in the dimensioning of FRP-strengthened elements, unless these elements are relatively new, so that the concrete can still be expected to develop substantial creep deformations (which is not the case in the case of old concrete structures).

Another important issue regarding time-effects is the poor behaviour of GFRP under sustained loading. Glass fibres exhibit premature tensile rupture under sustained stress, a

phenomenon called stress rupture. Hence the tensile strength of GFRP drops to very low values (as low as 20%) when the material carries permanent tension.

Stress corrosion occurs when the atmosphere or ambient environment is of a corrosive nature but not sufficiently so that corrosion would occur without the addition of stress. This phenomenon is time, stress level, environment, matrix and fibre related. Failure is deemed to be premature since the FRP fails at a stress level below its ultimate.

Carbon fibre is relatively unaffected by stress corrosion at stress levels up to 80% of ultimate. Glass and aramid fibers are susceptible to stress corrosion. The quality of the resin has a significant effect on time to failure and the sustainable stress levels. In general, the following order of fibres and resins gives increasing vulnerability either stress rupture or stress corrosion (Kelley et al. 1999): carbon-epoxy, aramid vinylester, glass polyester. We may also state that, in general, given the stress rupture of GFRP and the relatively poor creep behaviour of AFRP, it is recommended that when the externally bonded reinforcement is to carry considerable sustained load, composites with carbon fibres should be the designer's first choice.

The effects of temperature upon the creep performance of adhesives dictates that strengthening with FRP at elevated temperatures should only be carried out with suitably formulated adhesives. Finally, in prestressed concrete it should be ensured that stress transfer due to creep in the concrete will not result in excessive compressive forces being induced into the FRP.

9.9 Fatigue

Advanced unidirectional composites, such as CFRP, exhibit superior fatigue performance to that of steel. Pioneering research at the EMPA (Kaiser 1989, Deuring 1993) as well as additional studies (e.g. Barnes and Mays 1999) have shown that the dominant factor in the fatigue of FRP-strengthened beams is the fatigue of existing steel reinforcement. It is therefore recommended that the criteria for the fatigue design of CFRP strengthened beams should be to limit the stress range in the rebars to that permitted in an unstrengthened beam.

9.10 Impact

The knowledge of the impact behaviour of FRP-strengthened RC elements is relatively limited. In a recent study, Erki and Meier (1999) studied the impact response of four simply-supported 8 m beams externally strengthened for flexure, two with CFRP laminates and two with steel plates. Impact loading was induced by lifting one end of the beams and dropping it from given heights. The strain rates induced in the CFRP were at least three orders of magnitude greater than the strain rates used for testing CFRP coupons in tension. Comparisons of the results led to the conclusion that the beams strengthened with CFRP laminates performed well under impact loading, although they could not provide the same energy absorption as the beams strengthened with steel plates. Additional anchoring, at least at the ends of the externally bonded reinforcement to supplement the epoxy bonding and to prevent premature debonding of the CFRP, would improve the impact resistance of the RC elements.

9.11 Lightning, galvanic corrosion

GFRP and AFRP are insulators. Direct hits from lightning can cause some problems (scorching and burning) but generally this is not a major concern if the structure is earthed. CFRP is a conductor but has a relatively high resistivity, which causes it to heat up as the current passes through it. Studies from the aircraft industry have shown that a lightning strike has two main effects on unprotected CFRP: first, the main body of CFRP becomes so hot that the epoxy resin component vaporises; second, the structural properties of CFRP are affected after the carbon cools down (Meier 1995). The tensile strength should not be affected much, but the interlaminar shear and compressive strength will be lost. In the aircraft industry, aluminium grids are used to protect the composite in its outermost layers as it is well proven that lightning will not strike an object placed in a grounded metal cage.

In many FRP-strengthening applications, composites will not be susceptible to lightning strikes as they are inside buildings or in box girders, which is equivalent to grounded cages. Composites used in bridge strengthening are positioned either on the soffits of the beams, so that lightning will not have access to them, or around columns, in which case CFRP might require protection. If there are some situations where lightning might pose a risk, composites are to be protected using metal grids.

Finally, in order to avoid potential galvanic corrosion of steel reinforcement, carbon based FRP should not come in direct contact with steel.

References

Agarwal, B. D. and Broutman, L. J. (1990), *Analysis and performance of fibre composites*, John Wiley & Sons.

Ahmad, S. H. and Plecnik, J. M. (1989), *Transfer of composites technology to design and construction of bridges*. Report of the California State University.

American Concrete Institute (1996), *State-of-the-art report on fiber reinforced plastic reinforcement for concrete structures*. ACI Report 440R-96, Detroit, Michigan.

ASTM (1995), *Standard test method for tensile properties of polymer matrix composite materials*, D 3039/D 3039M. Annual book of ASTM Standards, Vol. 15.03, American Society for Testing and Materials (ASTM), Philadelphia, USA.

ASTM G23 (1996), *Standard practice for operating light-exposure apparatus (carbon-arc type) with and without water for exposure of nonmetallic materials*. National Institute of Standards and Technology, USA.

ASTM G53 (1996), *Standard practice for operating light - and water - exposure apparatus (fluorescent UV-condensation type) for exposure of nonmetallic materials*. National Institute of Standards and Technology, USA.

Barnes, R. A. and Mays, G. C. (1999), Fatigue performance of concrete beams strengthened with CFRP plates. *ASCE Journal of Composites for Construction*, **3**(2), 63-72.

Bizindavyi, L. and Neale, K. W. (1999), Transfer lengths and bond strengths for composites bonded to concrete. *ASCE Journal of Composites for Construction*, **3**(4), 153-160.

Blaschko, M. (1997), *Strengthening with CFRP*. Münchner Massivbau Seminar, TU München (In German).

Blaschko, M. and Zilch, K. (1999), Rehabilitation of concrete structures with CFRP strips glued into slits. In *Proceedings of the 12th International Conference on Composite Materials*, Paris, July 5-9.

Blaschko M., Nierdermeier R. and Zilch, K. (1998), Bond failure modes of flexural members strengthened with FRP. In *Proceedings of Second International Conference on Composites in Infrastructures*, Saadatmanesh, H. and Ehsani, M. R., eds., Tucson, Arizona, 315-327.

Caltrans (1997), Caltrans specifications on column casings. In *Proceedings of NIST Workshop on Standards Development for the Use of Fiber Reinforced Polymers for the Rehabilitation of Concrete and Masonry Structures*, January 7-8, 1998, Tucson, Arizona, 3.39-3.58.

CEB (1983), *Concrete under multiaxial states of stress, constitutive equations for practical design*. CEB Bulletin d'Information No. 156, Comité Euro-International du Béton, Lausanne, Switzerland.

CEB (1993), *CEB-FIP Model Code 1990, Design Code*. Comité Euro-International du Béton, Lausanne, Switzerland, Thomas Telford.

CEN (1991), *Eurocode 2: Design of concrete structures – Part 1-1: General rules and rules for buildings*. ENV 1992-1-1, Comité Européen de Normalisation, Brussels, Belgium.

CEN (1994), *Eurocode 1: Basis of design and actions on structures – Part 1: Basis of design*. ENV 1991-1, Comité Européen de Normalisation, Brussels, Belgium.

CEN (1995), *Adhesives. Determination of tensile lap-shear strength of rigid-to-rigid bonded assemblies*. EN 1645, Comité Européen de Normalisation, Brussels, Belgium.

CEN (1996), *Aeronautical- Plastics reinforced with carbon fibres – Unidirectional laminates – Tensile test parallel to the fibre direction*. EN 2561, Comité Européen de Normalisation, Brussels, Belgium.

CEN (1998 a), *Products and systems for the protection and repair of concrete structures: Test methods – Tests to measure the suitability of structural bonding agents for application to concrete surfaces*. EN 1799, Comité Européen de Normalisation, Brussels, Belgium.

CEN (1998 b), *Products and systems for the protection and repair of concrete structures: Test methods – Determination of compressive strength of repair mortar*. EN 12190, Comité Européen de Normalisation, Brussels, Belgium.

CEN (1998 c), *Products and systems for the protection and repair of concrete structures: Test methods. Determination of the coefficient of thermal expansion*. EN 1770, Comité Européen de Normalisation, Brussels, Belgium.

CEN (1999 a), *Products and systems for the protection and repair of concrete structures: Test methods – Determination of open time*. EN 12189, Comité Européen de Normalisation, Brussels, Belgium.

CEN (1999 b), *Products and systems for the protection and repair of concrete structures: Test methods – Determination of adhesion steel-to-steel for characterisation of structural bonding agents*. EN 12188, Comité Européen de Normalisation, Brussels, Belgium.

CEN (1999 c), *Products and systems for the protection and repair of concrete structures - Test methods - Measurement of bond strength by pull-off*. EN 1542. Comité Européen de Normalisation, Brussels, Belgium.

CEN (2001 a), *Products and systems for the protection and repair of concrete structures: Definitions – Requirements - Quality control and evaluation of conformity – Part 4: Structural bonding*. prEN 1504-4, Comité Européen de Normalisation, Brussels, Belgium.

CEN (2001 d), *Products and systems for the protection and repair of concrete structures: Test methods – Determination of glass transition temperature of polymers*. EN 12614, Comité Européen de Normalisation, Brussels, Belgium.

CEN (2001 b), *Products and systems for the protection and repair of concrete structures: Test methods – Part 3: Determination of early age shrinkage for structural bonding agents*. prEN 12617-3, CEN working document, Comité Européen de Normalisation, Brussels, Belgium.

CEN (2001 e), *Products and systems for the protection and repair of concrete structures – Test Methods – Water absorption and resistance to alkali for hydrophobic impregnations*. prEN 13580, CEN working document, Comité Européen de Normalisation, Brussels, Belgium.

CEN (2001 g), *Products and systems for the protection and repair of concrete structures: Test methods – Tests to determine the durability of structural bonding agents*. prEN 13733, CEN working document, Comité Européen de Normalisation, Brussels, Belgium.

CEN (2001 h), *Products and systems for the protection and repair of concrete structures: Test methods – Determination of fatigue under dynamic loading – Part 1: during cure*. prEN 13894-1, CEN working document, Comité Européen de Normalisation, Brussels, Belgium.

CEN (2001 i), *Products and systems for the protection and repair of concrete structures: Test methods – Determination of fatigue under dynamic loading – Part 2: in service*. prEN 13894-2, CEN working document, Comité Européen de Normalisation, Brussels, Belgium.

CEN (2001 f), *Products and systems for the protection and repair of concrete structures: Test methods - Determination of creep in shear*. prEN 13584-1, CEN working document, Comité Européen de Normalisation, Brussels, Belgium.

CEN (2001 c), *Structural adhesives - Determination of the pot life (working life) of multicomponent adhesives*. prEN 14022, CEN working document, Comité Européen de Normalisation, Brussels, Belgium.

Chai, Y. H., Priestley, M. J. N. and Seible, F. (1991), Seismic retrofit of circular bridge columns for enhanced flexural performance. *ACI Structural Journal*, **88**(5), 572-584.

Chen, W. F., Bazant, Z. P., Buyukozturk, O., Chang, T. Y., Darwin, D., Liu, T. C. Y. and Willam, K. J. (1981), *Constitutive relations and failure theories* (Chapter 2), CE-STR-81-21, ASCE Task Committee on Finite Element Analysis of Reinforced Concrete Structures.

Deuring, M. (1993), *Strengthening of RC with prestressed fiber reinforced plastic sheets*. EMPA Research Report 224, Dübendorf, Switzerland (in German).

Deuring, M. (1994), *Brandversuche an nachträglich verstärkten Trägern aus Beton*, EMPA nr. 148'795.

Deutsches Institut für Bautechnik (1998), Authorisation No. Z-36.12-54.

Deutsches Institut für Bautechnik (2000a), Authorisation No. Z-36.12-32.

Deutsches Institut für Bautechnik (2000b), Authorisation No. Z-36.12-57.

Erki, M. A. and Meier, U. (1999), Impact loading of concrete beams externally strengthened with CFRP laminates. *ASCE Journal of Composites for Construction*, **3**(3), 117-124.

Feldman, D. (1989), *Polymeric building materials*, Elsevier Science Publishers Ltd., UK.

FIP (1991), *Repair and strengthening of concrete structures*, FIP Guide to good practice, Fédération Internationale de la Précontrainte, London, UK, Thomas Telford.

German Institute of Construction Technology (1997), Authorisation No. Z-36.12-29 (English Translation).

Green, M., Bisby, L. A., Beaudoin, Y. and Labossiere, P. (1998), Effects of freeze-thaw action on the bond of FRP sheets to concrete. In *Durability of Fibre Reinforced Polymer (FRP) Composites for Construction CDCC '98*, 179-190.

Hollaway, L. C. and Leeming, M. B. (1999), *Strengthening of reinforced concrete structures, using externally-bonded FRP composites in structural and civil engineering*, Woodhead Publishing.

Holzenkämpfer, P. (1994), *Ingenieurmodelle des verbundes geklebter bewehrung für betonbauteile*. Dissertation, TU Braunschweig (In German).

ISO (1993 a), *Plastics – Polymers/resins in the liquid state or as emulsions or dispersions – Determination of viscosity using a rotational viscometer with defined shear rate*. ISO 3219, International Organisation for Standardization (also published as EN ISO 3219, 1995).

ISO (1993 b), *Plastics – Determination of flexural properties*. ISO 178, International Organisation for Standardization (also published as EN ISO 178, 1997).

ISO (1997), *Plastics – Determination of tensile properties, Part 5: Test conditions for unidirectional fibre-reinforced plastic components*. ISO 527-5, International Organisation for Standardization (also published as EN ISO 527-5, 1997).

Jansze, W. (1997), *Strengthening of reinforced concrete members in bending by externally bonded steel plates*. PhD dissertation, TU Delft, The Netherlands.

Kaiser, H. (1989), *Strengthening of reinforced concrete with CFRP plates*. Ph.D. dissertation, ETH Zürich (in German).

Karbhari, V. and Howie, I. (1997), Effect of composite wrap architecture on strengthening of concrete due to confinement: II-Strain and damage effects. *Journal of Reinforced Plastics and Composites*, **16**(2).

Karbhari, V. M. and Seible F. (1998), Design considerations for the use of fiber reinforced polymeric composites in the rehabilitation of concrete structures. In *Proceedings of NIST Workshop on Standard Development for the Use of FRP for the Rehabilitation of Concrete and Masonry Structures*, Tucson, Arizona, 59-72.

Kelley, P., Isley, F., Vatovec, M. and Mack J. (1999), *Sika CarboDur structural strengthening system, engineering guidelines for design and application*, Sika Corporation.

Khalifa, A., Gold, W. J., Nanni, A. and Aziz, A. M. I. (1998), Contribution of externally bonded FRP to shear capacity of rc flexural members. *ASCE Journal of Composites for Construction*, **2**(4), 195-202.

Kim, D.-H. (1995), *Composite structures for civil and architectural engineering*, E & FN Spon, London.

Kim, P. and Meier, H. (1991), *Das statische Biegeverhalten von Hybridträgern aus Aluminium und Kohlenstoffaserverstärkten Kunststoffen unter kurzzeitbelastungen*. EMPA Report No. 126537/2, Dübendorf (in German).

Lambotte, H. and Taerwe, L. (1990), Deflection and cracking of high-strength beams and slabs. In *Proceedings of the High-Strength Concrete 2nd International Symposium*, Ed. W. T. Hester, ACI SP-121, American Concrete Institute, Detroit, 109-128.

Lillistone, D. and Jolly, C. K. (2000), An innovative form of reinforcement for concrete columns using advanced composites, *The Structural Engineer*, **78**(23/24), 20-28.

Lubin, G. and Donohue, P. (1980), Real life ageing properties of composites. In *Proceedings of 35th Annual Technical Conference of the Reinforced Plastics and Composites Institute*, Section 17^E, 21.

Luke, P. S., Leeming, M. B. and Skwarski, A. J. (1998), ROBUST results for carbon fibre. *Concrete Engineering International*, **2**(2), 19-21.

Mack, J. K. and Holt, E. E. (1999), The effect of vapor barrier encapsulation of concrete by FRP strengthening systems. In *Proceedings of 44th International SAMPE Symposium and Exhibition*, Long Beach, California.

Malek, A. M., Saadatmanesh, H. and Krishnamoorthy, M. R. (1998), Prediction of failure load of R/C beams strengthened with FRP plate due to stress concentration at the plate end, *ACI Structural Journal*, **95**(2), 142-152.

Mander, J. B., Priestley, M. J. N. and Park, R. (1988), Theoretical stress-strain model for confined concrete. *Journal of Structural Engineering, ASCE*, **114**(8), 1804-1826.

Matthys, S. (2000), *Structural behaviour and design of concrete members strengthened with externally bonded FRP reinforcement*. Doctoral thesis, Ghent University.

Matthys, S. and Blontrock, H. (2000), Innovaties in uitwendig gelijmde vezelcomposietwapening voor de versterking van betonconstructies: Experimenteel onderzoek. In *Proceedings colloquium 'Betonversterking met uitwendig gelijmde wapening: staal en kunststof'*, Belgische Vereniging tot Studie, Beproeving en Gebruik der Materialen (BSVM).

Matthys, S., Taerwe, L. and Audenaert, K. (1999), Tests on axially loaded concrete columns confined by FRP sheet wrapping. In *Proceedings of the 4th International Symposium on FRP for Reinforced Concrete Structures*, Baltimore, USA, 217-228.

Mays, G. C. and Hutchinson, A. R. (1992), *Adhesives in civil engineering*, Cambridge University Press.

Meier, H. and Bleibler, A. (1999), The latest R&D in Structural Strengthening with bonded CFRP plates. In *Proceedings of Structural Faults & Repair-99*, London.

Meier, U. (1987), Bridge repair with high performance composite materials. *Material & Technik*, **4**, 125-128 (in German).

Meier U. (1995), Strengthening of structures using carbon fibre/epoxy composites. *Construction and Building Materials*, **9**(6), 341-351.

Mirmiran, A., Kargahi, M., Samaan, M. and Shahawy, M. (1996), Composite FRP-concrete column with bi-directional external reinforcement. In *Proceedings of 1st International Conference on Composites in Infrastructure*, Tucson, Arizona, USA, 888-902.

Mirmiran, A. and Shahawy, M., (1997), Behavior of concrete columns confined by fiber composites, *Journal of Structural Engineering, ASCE*, **123**(5), 583-590.

Monti, G., Nisticò, N. and Santini, S. (2001), Design of FRP jackets for upgrade of circular bridge piers. *Journal of Composites for Construction, ASCE*, in print.

Mutsuyoshi, H., Ishibashi, T., Okano, M. and Katsuki, F. (1999), New design method for seismic retrofit of bridge columns with continuous fiber sheet – Performance-based design.

In *Fiber Reinforced Polymer Reinforcement for Reinforced Concrete Structures*, ed. C. W. Dolan, S. H. Rizkalla and A. Nanni, ACI Report SP-188. Detroit, Michigan, 229-241.

Nanni, A. and Bradford, N. M. (1995), FRP jacketed concrete under uniaxial compression. *Construction and Building Materials*, **9**(2), 115-124.

Neubauer, U. and Rostásy, F. S. (1997), Design aspects of concrete structures strengthened with externally bonded CFRP-plates. In *Concrete+Composites, Proceedings of the 7th International Conference on Structural Faults and Repair*, **2**, 109-118.

Neubauer, U. and Rostásy, F. S. (1999), Bond failure of concrete fibre reinforced polymer at inclined cracks – experiments and fracture mechanics model. In *Proceedings of the 4th International Conference on Fibre Reinforced Polymer Reinforcement for Concrete Structures*, Eds. C. W. Dolan, S. H. Rizkalla and A., Nanni, ACI, Michigan, USA, 369-382.

Neuner, J. and Falabella, R. (1996), *Composite anchor system – flatwise tensile and shear testing*. Internal Report, Hexcel Corporation.

Niedermeier, R. (2000), *Zugkraftdeckung bei klebarmierten bauteilen (Envelope line of tensile forces while using externally bonded reinforcement)*. Doctoral Dissertation, TU München, (In German).

Oehlers, D. J. and Moran, J. P. (1990), Premature failure of externally plated reinforced concrete beams. *ASCE Journal of Structural Engineering*, **116**(4), 978-995.

Pantazopoulou, S. J. and Mills, R. H. (1995), Microstructural aspects of the mechanical response of plain concrete. *ACI Materials Journal*, **92**(6), 605-616.

Pantuso, A., Neubauer, U. and Rostasy, F. S. (2000), Effects of thermal mismatch between FRP and concrete on bond. In *Minutes of 4th ConFibreCrete Meeting*, Lille, France.

Pereg, D. (1996), *Tyfo S woven fabric-reinforced composite laminate*. Report No 720076-1R, United States Testing Company, Inc.

Picher, F., Rochette, P. and Labossière, P. (1996), Confinement of concrete cylinders with CFRP. In *Proceedings of 1st International Conference on Composite Infrastructures*, Tucson, Arizona, USA, 829-841.

Pichler, D. (1993), *Die wirkung von anpressdrücken auf die verankerung von klebelamellen*. Doctoral Dissertation, Universität Innsbruck (In German).

Plevris, N. and Triantafillou, T. C. (1994), Time-dependent behaviour of RC members strengthened with FRP laminates. *ASCE Journal of Structural Engineering*, **120**(3), 1016-1042.

Popovics, S. (1973), Numerical approach to the complete stress-strain relation for concrete. *Cement and Concrete Research*, **3**(5), 583-599.

Priestley, M. J. N. and Seible, F. (1995), Design of seismic retrofit measures for concrete and masonry structures. *Construction and Building Materials*, **9**(6), 365-377.

Richart, F. E., Brandtzaeg, A. and Brown, R. L. (1929), *The failure of plain and spirally reinforced concrete in compression*. Engineering Experiment Station Bulletin, 190, University of Illinois, Urbana, USA, April.

Roberts, T. M. (1989), Approximate analysis of shear and normal stress concentrations in the adhesive layer of plated RC beams. *The Structural Engineer*, **67**(12), 229-233.

Rostásy, F. S., Holzenkämpfer, P. and Hankers, C. (1996), Geklebte Bewehrung für die Verstärkung von Betonbauteilen. In *Betonkalender 1996*, **II**, 547-576.

Saadatmanesh, H., Ehsani, M. R. and Li, M. W. (1994), Strength and ductility of concrete columns externally reinforced with fiber composite straps. *ACI Structural Journal*, **91**(4), 434-447.

Saadatmanesh, H., Ehsani, M. R., and Jin, L. (1997), Seismic strengthening of circular bridge piers with fiber composites. *ACI Structural Journal*, **93**(6), 639-647.

Saafi, M., Toutanji, H. A. and Li, Z. (1999), Behavior of concrete columns confined with fiber reinforced polymer tubes. *ACI Materials Journal*, **96**(4), 500-509.

Samaan, M., Mirmiran, A. and Shahawy, M. (1998), Model of concrete confined by fiber composites. *Journal of Structural Engineering*, ASCE, **124**(9), 1025-1031.

Seible, F., Priestley, M. J. N. and Innamorato, D. (1995 a), Earthquake retrofit of bridge columns with continuous fiber jackets. In *Design guidelines, Advanced composite technology transfer consortium*, **2**, Report No. ACTT-95/08, University of California, San Diego, USA.

Seible, F., Burgueño, R., Abdallah, M. G. and Nuismer, R. (1995 b), Advanced composite carbon shell systems for bridge columns under seismic loads, Progress in research and practice. In *Proceedings of National Seismic Conference on Bridges and Highways*, San Diego, CA, USA.

Soudki, K. A. and Green, M. F. (1997), Freeze-thaw response of CFRP wrapped concrete. *Concrete International*, **19**, 64-72.

Spoelstra, M. R. and Monti, G., (1999), FRP-confined concrete model. *Journal of Composites for Construction*, ASCE, **3**(3), 143-150.

Steckel, G. L., Hawkins, G. F. and Bauer J. L. (1998), Environmental durability testing of composites for seismic retrofit of bridge columns. In *Proceedings of Second International Conference on Composites in Infrastructures*, Saadatmanesh, H. and Ehsani, M. R., eds., Tucson, 460-475.

Täljsten, B. (1994), *Strengthening of existing concrete structures with epoxy bonded plates of steel or fibre reinforced plastics*. Doctoral Thesis, Luleå University of Technology.

Täljsten, B. (1997), Strengthening of beams by plate bonding. *Journal of Materials in Civil Engineering*, ASCE, **9**(4), 206-212.

Täljsten B. (1998), *Förstärkning av betongkonstruktioner med stålplåt och avancerade kompositmaterial utsatta för vridning*, Forskningsrapport, Luleå tekniska universitet, Avdelningen för konstruktionsteknik, Institutionen för Väg- och vattenbyggnad, 1998:01, ISSN 1402-1528 (In Swedish).

Täljsten, B. (1999 a), *Förstärkning av befintliga betongkonstruktioner med kolfiberväv eller laminat, Dimensionering, material och utförande*. Technical Report 1999:12, Lulea University of Technology (In Swedish).

Täljsten, B. (1999 b), *Strengthening of existing concrete structures with carbon fibre fabrics or laminates. Design, material and execution*. Extract from Swedish National Railroad and Road Codes.

Täljsten, B. and Elfgren, L. (2000), Strengthening concrete beams for shear using CFRP-materials, Evaluation of different application methods. *Journal of Composites, Part B*, accepted for publication.

TMR ConFibreCrete, fib TG9.3 and ISIS (2001), *International Round Robin Tests for FRP Reinforcement*, <http://www.shef.ac.uk/~tmrnet/rrt>.

Toutanji, H. and Balaguru, P. (1998), Durability characteristics of concrete columns wrapped with FRP tow sheets. *Journal of Materials in Civil Engineering*, ASCE, **10**(1), 52-57.

Triantafillou, T. C. (1998), Shear strengthening of reinforced concrete beams using epoxy-bonded FRP composites. *ACI Structural Journal*, **95**(2), 107-115.

Triantafillou, T. C. (2001), Seismic retrofitting of structures using FRPs. *Progress in Structural Engineering and Materials*, **3**(1), in print.

Triantafillou, T. C. and Antonopoulos, C. P. (2000), Design of concrete flexural members strengthened in shear with FRP. *ASCE Journal of Composites for Construction*, **4**(4), 198-205.

Triantafillou, T. C. and Deskovic, N. (1991), Innovative prestressing with FRP sheets: mechanics of short-term behavior. *Journal of Engineering Mechanics*, ASCE, **117**(7), 1652-1672.

Triantafillou, T. C., Deskovic, N. and Deuring, M. (1992), Strengthening of concrete structures with prestressed fiber reinforced plastic sheets. *ACI Structural Journal*, **89**(3), 235-244.

Triantafillou, T. C., Kim, P. and Meier, U. (1991), Optimization of hybrid aluminum/CFRP box beams. *International Journal of Mechanical Sciences*, **33**(9), 729-739.

Triantafillou, T. C. and Plevris, N. (1992), Strengthening of RC beams with epoxy-bonded fibre-composite materials. *Materials and Structures*, **25**, 201-211.

Tysl, S. R., Imbrogno, M. and Miller, B. (1998), Effect of surface delamination on the freeze/thaw durability of CFRP-reinforced concrete beams. In *Durability of Fibre Reinforced Polymer (FRP) Composites for Construction CDCC '98*, Sherbrooke, Canada, 317-324.

Winistoerfer, A. and Mottram, T. (1997), The future of pin-loaded straps in civil engineering applications. In *Recent Advances in Bridge Engineering, Proceedings of the US-Canada-Europe Workshop on Bridge Engineering*, ed. U. Meier and R. Betti, EMPA Switzerland, 115-120.

Yagi, K., Tanaka, T., Sakai, H. and Otaguro, H. (1997), Durability of carbon fiber sheet for repair and retrofitting. In *Non-Metallic (FRP) Reinforcement for Concrete Structures, Proceedings of the Third International Symposium*, **2**, Sapporo, Japan, 259-266.

Yamaguchi, T., Nishimura, T., and Uomoto, T. (1998), Creep model of FRP rods based on fibre damaging rate. In *Proceedings of 1st International Conference on Durability of Fibre Reinforced Polymer (FRP) Composites for Construction*, Eds. B. Benmokrane and H. Rahman, Sherbrooke, Canada, 427-437.

Zehetmaier, G. (2000), Entwicklung mechanischer endverankerungen für aufgeklebte CFK-lamellen. (Development of mechanical anchorages for externally bonded CFRP-strips). In *Massivbau 2000, Forschung, Entwicklungen und Anwendungen, Münchner Massivbau-Seminar 2000* (Editor: K. Zilch), 217-232, Springer VDI Verlag, Düsseldorf.

Zilch, K., Niedermeier, R. and Blaschko, M. (1998), *Bericht über versuche zum verstärken von betonbauteilen mit CFK (Test report on retrofitting concrete members with CFRP)*. Versuchsbericht Nr. 1310, Technische Universität München, Lehrstuhl für Massivbau (In German).

Symbols

Roman upper case letters

A_c	net area of concrete
$A_{c,eff}$	effective concrete area in tension
A_e	effectively confined concrete core
A_f	area of FRP reinforcement
A_g	gross area of concrete
A_s	total area of longitudinal steel reinforcement
A_{st}	cross sectional area of transverse steel
A_{s1}	area of tensile steel reinforcement
A_{s2}	area of compressive steel reinforcement
A_u	area of unconfined concrete
D	diameter of circular cross section
E_c	initial tangent modulus of elasticity of concrete
\bar{E}_c	normalised to f_{co} value of E_c
E_f	modulus of elasticity of FRP
E_{fib}	modulus of elasticity of fibres
E_{fk}	characteristic value of the secant modulus of elasticity of FRP
E_{fm}	mean secant modulus of elasticity of FRP
E_{fu}	modulus of elasticity of FRP at ultimate
E_j	modulus of FRP jacket
E_m	modulus of elasticity of matrix
E_s	modulus of elasticity of steel
E_{sec}	secant modulus of elasticity of concrete
$E_{sec,u}$	secant modulus of elasticity of concrete at ultimate
G_a	shear modulus of adhesive
G_f	fracture energy of concrete
G_{fk}	characteristic value of fracture energy of concrete
I_c	moment of inertia of transformed cracked section
I_{o2}	moment of inertia of transformed cracked section before strengthening
I_{sec}	section upgrading index
I_1	moment of inertia of transformed uncracked section
I_2	moment of inertia of transformed cracked section
K_{conf}	stiffness of the FRP confinement
L	distance from end of FRP to support
L_p	plastic hinge length
M	maximum column bending moment
M_{cr}	cracking moment
M_d	design moment
M_k	characteristic value of moment
M_o	acting moment during strengthening
M_{Rd}	resisting design moment
M_u	moment capacity of column after retrofit
$M_{x=0}$	moment acting on section corresponding to end of FRP
N_c	force in concrete
N_f	force in FRP, or uniform tension force in FRP helix

N_{fd}	design value of force in FRP
N_{fa}	FRP force to be anchored
$N_{fa,max}$	maximum anchorable FRP force N_{s1} force in tensile steel reinforcement
N_{sd}	design value of force in steel reinforcement
N_{s1}	force in tensile steel reinforcement
N_{s2}	force in compressive steel reinforcement
R	curvature of helix
T_{fd}	design value of torsional moment resisted by the FRP
T_g	glass transition temperature
V	maximum column shear force
V_{cd}	design shear capacity of the concrete
V_d	design shear force
V_{fd}	design value of shear force carried by the FRP
V_{fib}	volume fraction of fibres
V_m	volume fraction of matrix
V_{Rd}	design shear resistance
V_{Rd1}	design shear resistance of member without shear reinforcement
V_{Rd2}	design shear force that can be carried without web failure
V_{Rp}	resisting shear force at which shear crack peeling is initiated
V_{sd}	design shear force
V_u	shear capacity of column after retrofit
V_{wd}	contribution of steel shear reinforcement to design shear capacity
$V_{x=0}$	shear force acting on section corresponding to end of FRP

Roman lower case letters

a	deflection, or shear span
a_1	deflection in uncracked state
a_2	deflection in fully cracked state
b	width of beam
b_f	width of FRP
b_w	minimum width of cross section over the effective depth
c_f	factor relating the concrete fracture energy to the mean tensile strength
d	effective depth of the member
d_j	diameter of FRP jacket
d_s	diameter of steel rebars, or diameter of steel spiral (hoops)
d_1	distance from centroid of tensile steel to extreme tensile fibre
d_2	distance from centroid of compressive steel to extreme compressive fibre
f_{cbd}	design bond shear strength of concrete
f_{cc}	confined concrete strength
\bar{f}_{cc}	normalised to f_{co} value of f_{cc}
f_{cc}^{ava}	confined concrete strength (available in section to be upgraded)
f_{cd}	design value of the concrete compressive strength
f_{ck}	characteristic value of the concrete compressive strength
f_{cm}	mean value of the concrete compressive strength
f_{co}	unconfined concrete strength
f_{ctd}	design value of the concrete tensile strength

$f_{ct,fl}$	flexural strength of concrete
f_{ctk}	characteristic value of the concrete tensile strength
$f_{ctk,0.95}$	upper bound characteristic tensile strength of concrete
f_{ctm}	mean value of the concrete tensile strength
f_{cu}	concrete strength at ultimate
f_f	tensile strength of the FRP
f_{fd}	design value of the FRP tensile strength
f_{fib}	tensile strength of fibres
f_{fk}	characteristic value of the FRP tensile strength
f_{fm}	mean value of the FRP tensile strength
f_j	ultimate strength of FRP jacket
f_ℓ	maximum confining stress
\bar{f}_ℓ	normalised to f_{co} value of f_ℓ
$f_{\ell,eff}$	effective maximum confining stress
f_m	tensile strength of matrix
f_y	steel yield strength
f_{yd}	design value of the steel yield strength
f_{yk}	characteristic value of the steel yield strength
h	total depth of the member
h_f	thickness of flange in T-beams
k	factor relating flexural to tensile strength of concrete, or reduction factor
k_b	size factor
k_c	concrete compaction factor
k_e	arching-effect (confinement effectiveness) coefficient
k_M	coefficient depending on type of loading
ℓ	span length
ℓ_b	bond length
ℓ_c	length of cantilever beam
$\ell_{b,max}$	maximum anchorable length
ℓ_t	transmission length
p	pitch of helix
r	radius of helix
r_c	radius of rounded corner
s	spacing (pitch) of hoops (spiral)
s'	clear spacing between FRP wraps
s_f	relative displacement between FRP and concrete (slip), or spacing of FRP strips
S_{f1}, S_{f0}	parameters of approximate bond model
$S_{f,max}$	maximum spacing of FRP
S_{rm}	mean value of crack spacing
t_a	thickness of adhesive
t_f	thickness of FRP
t_{fib}	nominal thickness of fibre sheet or fabric
t_j	thickness of FRP jacket
u_f	bond perimeter of FRP reinforcement
u_s	bond perimeter of steel reinforcement
w'_i	clear distance between rounded corners
w_k	characteristic value of crack width
x	depth of the compression zone
x_e	depth of the compression zone from linear elastic analysis

X_{lim}	limiting value on the depth of the compression zone
X_o	depth of the compression zone before strengthening
Z_e	lever arm (linear elastic analysis)
Z_m	mean lever arm of internal forces

Greek upper case letters

Φ_u	curvature at ultimate
Φ_y	yield curvature

Greek lower case letters

α	reduction factor for the effect of inclined cracks on bond strength, or reduction factor for the reduced compressive strength under long-term load, or angle between principal fibre orientation and longitudinal axis of member
β	coefficient that relates mean and characteristic value of crack width, or parameter of damage law (a property of concrete)
β_1	coefficient accounting for the bond characteristics of the reinforcement
β_2	coefficient accounting for the type of loading
γ_a	material safety factor for the adhesive (verification of bond failure)
γ_c	material safety factor for the concrete
γ_{cb}	material safety factor for the concrete (verification of bond failure)
γ_F	partial safety factor for the loads
γ_f	material safety factor for the FRP
γ_{fb}	material safety factor for the FRP if bond failure controls
γ_M	partial safety factor for the materials
γ_s	material safety factor for the steel reinforcement
δ_G	stress block centroid coefficient
δ_{sec}^{ava}	available sectional ductility
δ_{sec}^{tar}	target sectional ductility
δ_χ	ductility curvature index
$\delta_{\chi,min}$	minimum ductility curvature index
ϵ	strain
ϵ_A	area strain in concrete
ϵ_c	concrete strain in the extreme compression fiber, or axial strain in concrete
ϵ_{cc}	compressive strain at confined peak strength f_{cc}
ϵ_{co}	initial concrete strain in the extreme compressive fibre before strengthening, or unconfined concrete strain at peak stress
ϵ_{cu}	ultimate concrete strain
ϵ_{cu}^{ava}	confined concrete strain (available in section to be upgraded)
ϵ_f	FRP strain
$\epsilon_{fd,e}$	design value of effective FRP strain
$\epsilon_{f,e}$	effective FRP strain
$\epsilon_{fk,e}$	characteristic value of effective FRP strain
$\epsilon_{f,lim}$	limiting FRP strain
$\epsilon_{f,min}$	minimum allowable FRP strain at ultimate

ϵ_{fu}	ultimate FRP strain
$\epsilon_{fu,c}$	FRP strain in the critical section at ultimate
ϵ_{fud}	design value of the ultimate FRP strain
ϵ_{fue}	effective ultimate FRP strain
ϵ_{fuk}	characteristic value of the ultimate FRP strain
ϵ_{fum}	mean value of the ultimate FRP strain
ϵ_j	circumferential strain in FRP jacket
ϵ_{ju}	FRP jacket effective ultimate circumferential strain
$\epsilon_{j=l}$	circumferential strain in FRP jacket (equal to lateral strain in concrete)
ϵ_l	lateral strain in concrete
ϵ_{lu}	lateral strain in concrete at ultimate
ϵ_{max}	maximum allowable FRP strain
ϵ_r	strain in the reinforcement
$\epsilon_{m,r}$	mean strain of steel reinforcement with respect to surrounding concrete
ϵ_{su}	ultimate strain of the steel reinforcement
$\epsilon_{su,c}$	steel strain in the critical section at ultimate
ϵ_{s1}	tensile steel strain
ϵ_{s2}	compressive steel strain
ϵ_{yd}	design value of the yield strain of the steel reinforcement
ϵ_{yk}	characteristic value of the yield strain of the steel reinforcement
ϵ_o	initial strain at the extreme tensile fibre before strengthening
ϵ_2	tensile reinforcement strain in the cracked state
ζ	tension stiffening coefficient
ζ_b	tension stiffening coefficient
η	FRP stress limitation coefficient to account for creep rupture
θ	angle of diagonal crack with respect to the member axis
μ	dilation rate
μ_{Δ}	displacement ductility factor
μ_{Φ}	curvature ductility factor
$\xi = x/d$	relative depth of the compression zone
ξ_b	bond parameter
$\rho_{c,eff}$	ratio of effective concrete area in tension
ρ_{eq}	equivalent reinforcement ratio
ρ_f	FRP reinforcement ratio
ρ_j	volumetric ratio of FRP jacket in circular columns
ρ_{jx}	volumetric ratio of FRP jacket in rectangular columns, x direction
ρ_{jy}	volumetric ratio of FRP jacket in rectangular columns, y direction
ρ_s	longitudinal steel reinforcement ratio
ρ_{sg}	reinforcement ratio of longitudinal steel to the gross cross-sectional area
ρ_{st}	volumetric ratio of transverse steel
σ	stress
σ_c	stress in concrete
σ_f	FRP stress
σ_{fad}	design value of FRP tensile stress at the end anchorage
$\sigma_{fad,max}$	design value of maximum anchorable FRP tensile stress
$\sigma_{fak,max}$	characteristic value of maximum anchorable FRP tensile stress
σ_{fd}	design value of FRP stress
$\max \Delta \sigma_{fd}$	design value of maximum possible increase in FRP tensile stress between two subsequent cracks
σ_{fk}	characteristic FRP stress

$\max \Delta\sigma_{fk}$	characteristic value of maximum possible increase in FRP tensile stress between two subsequent cracks
σ_j	stress in FRP jacket
σ_ℓ	lateral confining pressure
$\sigma_{\ell,c}$	lateral confining pressure exerted by circular FRP wraps
$\sigma_{\ell,eff}$	effective lateral confining stress
$\sigma_{\ell,h}$	lateral confining pressure exerted by FRP helix
σ_r	stress in the reinforcement (steel or FRP)
σ_s	steel stress
τ_b	bond shear stress
τ_{fl}	maximum shear stress in the bilinear bond-model
τ_{flk}	characteristic value of maximum shear stress in the bilinear bond-model
τ_{fm}	mean bond stress of the FRP
τ_{Rd}	design value of resisting shear strength of concrete
τ_{Rk}	characteristic shear strength of concrete
τ_{Rp}	resisting shear stress corresponding to initiation of peeling
τ_{sm}	mean bond stress of steel reinforcement
χ_u	curvature at ultimate
χ_y	curvature at yield
ψ	load combination factor, or stress block area coefficient